

行政院所屬各機關因公出國人員出國報告書
(出國類別：其他)

「再生能源憑證中心暨第三方檢測驗證計畫」
技術合作交流計畫

服務機關：經濟部標準檢驗局

出國人 職稱姓名：局長劉明忠、主任秘書謝翰璋

出國地點：英國、德國、波蘭

出國期間：中華民國 106 年 9 月 3 日至 9 月 16 日

報告日期：中華民國 106 年 12 月 14 日

目錄

	頁次
圖目錄.....	iv
表目錄.....	vi
壹、 目的.....	1
貳、 出國行程概要	2
參、 參訪人員名單	4
肆、 參訪紀要	6
一、 9月4日(週一)	6
駐英國台北代表處經濟組	6
碳信託(Carbon Trust) 組織.....	7
碳揭露專案(Carbon Disclosure Project, CDP) 機構.....	10
二、 9月5日(週二)	12
Global Maritime (GM)	12
Green Giraffe (GG).....	15
駐英國台北代表處	18
三、 9月6日(週三)	20
E.ON 及 London Offshore Consultant (LOC)	20
四、 9月7日(週四)	30
K2 Management (K2) 並見證合作備忘錄簽屬	30
德國 Fraunhofer IWES 風力機機艙動力鏈測試實驗室.....	33
五、 9月8日(週五)	40
德國海事局(Bundesamt für Seeschifffahrt und Hydrographie, BSH).....	40
駐德國台北代表處	42
DEWI Offshore Certificate Center GmbH (DEWI OCC).....	43

六、 9月11日(週一)	47
南德意志集團(TÜ V SÜ D)	47
立恩威集團(DNV GL)	50
七、 9月12日(週二)	52
波蘭認證中心(Polish Centre for Accreditation, PCA)	52
八、 9月13日(週三)	57
波蘭電力交易中心(Towarowa Gielda Energii SA, TGE)	57
駐波蘭代表處	61
九、 9月14日(週四)	63
波蘭化學物質局(Bureau for Chemical Substances, BCS)	63
十、 9月15日(週五)	66
波蘭證券交易所	66
伍、 備忘錄內容	68
陸、 心得	70
柒、 致謝	72
捌、 附件	73

圖目錄

	頁次
圖 1 Carbon Trust 再生能源電力標籤.....	8
圖 2 由本局謝翰璋主任秘書 (左五)率隊拜訪英國碳信託於會後合影留念.....	9
圖 3 本局謝翰璋主任秘書(左四)率隊拜訪英國碳揭露技術總監 Mr. Pedro.....	11
圖 4 Global Maritime 與國內專業法人共同簽署合作備忘錄.....	14
圖 5 Green Giraffe 的 Jérôme Guillet 總經理向大家說明 Green Giraffe 背景.....	16
圖 6 本局劉明忠局長致詞.....	17
圖 7 Green Giraffe 與財團法人台灣經濟研究院簽署 MoU.....	17
圖 8 駐英國台北代表處向本團簡介代表處工作內容.....	19
圖 9 本局劉明忠局長(右)拜會林永樂代表(左) 巧遇 Andrew Rosindell 議員(中).....	19
圖 10 陸上電纜路線圖.....	23
圖 11 Rampion 離岸風場佈局圖.....	24
圖 12 Rampion 離岸風場佈局與陣列海纜配置圖.....	25
圖 13 Rampion 離岸風場計畫辦公室雙方交流.....	26
圖 14 Rampion 離岸風場協調中心.....	27
圖 15 LOC 與國內專業法人共同簽署合作備忘錄.....	28
圖 16 K2 與國內專業法人共同簽署合作備忘錄.....	31
圖 17 本局劉明忠局長(左)與中國驗船中心趙國樑董事長(右)致詞.....	32
圖 18 K2 執行長 Henrik Stamer 先生(左)與台經院劉兆歡組長(右)簡報說明.....	32
圖 19 IWES Nacelle 測試場佈置示意圖(IWES 資料圖片).....	35
圖 20 IWES Nacelle 測試場待測物移載設備.....	36
圖 21 IWES Nacelle 測試場設備安裝(IWES 資料圖片).....	36
圖 22 IWES Nacelle 動力鏈測試設備 (IWES 資料圖片).....	37
圖 23 IWES Nacelle 動力鏈測試設備內部構造.....	37
圖 24 Fraunhofer 技術部門經理 Torben Jersch 介紹動力鏈測試系統構造.....	38
圖 25 與 Idom 公司討論國內規劃之機艙動力鏈測試系統規格.....	38
圖 26 參訪團與 Fraunhofer、Idom 公司及 ABB 公司人員合影.....	39
圖 27 BSH 局長 Monika Breuch-Moritz (站立者)致詞.....	41
圖 28 Dr. Nico Nolte(左一)、劉明忠局長(中)以及 Dr. Manfred Zeiler(右一).....	41
圖 29 本局劉明忠局長(右)致謝駐德國漢堡辦事處沈文強處長(左).....	43
圖 30 國內專業法人與 DEWI-OCC 完成 MOU 簽署.....	45
圖 31 簽署合作備忘錄後雙方互贈禮物留念.....	46
圖 32 國內專業法人與 TÜV SÜD 簽署 MOU.....	49
圖 33 DNV GL 副總裁 Kim Mørk 致詞.....	51
圖 34 與 DNV GL 簽訂合作備忘錄.....	51
圖 35 產品進入歐盟之案例概述.....	54
圖 36 PCA 進行簡報.....	55

圖 37	本局劉明忠局長(左一)與 PCA 主任 Ms. Lucyna Olborska(右一)討論中.....	56
圖 38	電源證書的流程.....	58
圖 39	波蘭歷年再生能源裝置量.....	58
圖 40	國內專業法人簡報.....	59
圖 41	本局劉明忠局長(左)致謝 TGE 董事會主席 Pawel Ostrowski(右).....	59
圖 42	參訪團隊與 TGE 人員合影.....	60
圖 43	參訪團隊與駐波蘭代表處人員會談.....	62
圖 44	化學物質局組織架構圖.....	63
圖 45	BCS 與我參訪團隊交流情形.....	64
圖 46	BCS 與 TAF 簽署合作備忘錄.....	64
圖 47	本局劉明忠局長(中)與波蘭證券交易所理事會主席 Dr. Marek Dietl (左)及副主席 Mr. Michal Cieciorski (右)於會談後合影留念.....	66

表目錄

	頁次
表 1 出國行程概要	2
表 2 參訪人員名單.....	4
表 3 拜訪駐英國代表處經濟組與會人員名單.....	7
表 4 拜訪英國碳信託與會人員名單.....	10
表 5 拜訪英國碳揭露與會人員名單.....	12
表 6 拜訪 Global Maritime 與會人員名單.....	15
表 7 拜訪 Green Giraffe 與會人員名單.....	18
表 8 駐英國代表處與會人員名單.....	20
表 9 Rampion 離岸風場基本資料表.....	21
表 10 Rampion 離岸風場開發時程表.....	24
表 11 拜訪 E.ON 及 LOC 與會人員名單.....	29
表 12 拜訪 K2 與會人員名單.....	33
表 13 拜訪 Fraunhofer 與會人員名單.....	39
表 14 拜訪 BSH 與會人員名單.....	42
表 15 拜訪駐德國漢堡辦事處與會人員名單.....	43
表 16 DEWI-OCC 與會人員名單.....	47
表 17 拜訪 TÜV SÜD 與會人員名單.....	49
表 18 拜訪 DNVGL 與會人員名單.....	52
表 19 拜訪 PCA 與會人員名單.....	56
表 20 TGE 與會人員名單.....	61
表 21 駐波蘭代表處與會人員名單.....	62
表 22 波蘭化學物質局與會人員名單.....	65
表 23 波蘭證券交易所理事會與會人員名單.....	67

壹、目的

依據政府能源政策，2025 年時再生能源占比將達 20%，其中太陽光電將建置 20 GW，離岸風力發電將建置 3 GW，合計須投入資金達 1.75 兆之新台幣。因此，推行再生能源，政策上必須多管齊下，發行再生能源憑證就是其中之一的做法。

另外，由於國內金融、保險單位對離岸風電較為陌生，因此，風電業者在取得融資上比較困難，而歐洲先進國家，如英國、德國在離岸風電的發展已有多年經驗，也有許多國際知名的第三方檢測驗證單位，故本局依據「再生能源憑證查核系統暨籌備推動辦公室計畫」之工作內容及實施方法，與英國碳信託(Carbon Trust)、碳揭露專案(Carbon Disclosure Project, CDP)、Global Maritime Consultant (GMC)、Green Giraffe、Rampion 離岸風場計畫、London Offshore Consultant (LOC)、德國 K2 management (K2)、德國海事局(Bundesamt für Seeschifffahrt und Hydrographie, BSH)、DEWI Offshore Certificate Center GmbH (DEWI OCC)、南德意志集團(TÜV SÜD)、立恩威集團(DNVGL)、波蘭認證中心(Polish Centre for Accreditation, PCA)、波蘭電力交易中心(Towarowa Gielda Energii SA, TGE)、波蘭化學物質局(Bureau for Chemical Substances, BCS)等國家再生能源相關單位、機構，交流推動再生能源憑證經驗與簽署合作備忘錄。

本次參訪歐洲多個再生能源相關單位，有助於了解歐洲於再生能源憑證之發展，及其開發離岸風力發電之經驗，如：離岸風能及建置示範風場之成功經驗，並強化與國際具離岸風場實務開發經驗廠商間之交流，學習國際知名第三方檢測驗證單位實務經驗，開啟合作之門，做為臺灣發展再生能源建置相關技術能量之參考。

貳、出國行程概要

表 1 出國行程概要

月	日	星期	訪 問 對 象		工 作 內 容	備 註
			國家	機構或個人		
9	3	日	英國		搭飛機前往英國倫敦	
9	4	一	英國	駐英國台北代表處經濟組 碳信託(Carbon Trust) 碳揭露專案(Carbon Disclosure Project, CDP)	與碳信託、碳揭露專案技術交流	
9	5	二	英國	Global Maritime (GM) Green Giraffe (GG) 駐英國台北代表處	與 Global Maritime、Green Giraffe 技術交流與簽署 MoU	
9	6	三	英國	Rampion 離岸風場計畫 London Offshore Consultant (LOC)	與 Rampion 離岸風場計畫團隊技術交流(如：E.ON、LOC)。並與 LOC 簽署 MoU	
9	7	四	德國	K2 Management (K2)	與 K2 技術交流並簽署 MoU	
9	8	五	德國	德國海事局(Bundesamt für Seeschifffahrt und Hydrographie, BSH) 駐德國漢堡辦事處 DEWI Offshore Certificate Center GmbH (DEWI OCC)	與德國海事局、DEWI 技術交流，並與 DEWI 簽署 MoU	
9	9 10	六 日	德國		準備會議資料	
9	11	一	德國	TÜ V SÜ D DNV GL	與 TÜ V SÜ D、DNV GL 技術交流與簽署 MoU	
9	12	二	波蘭	波蘭認證中心(Polish Centre for Accreditation, PCA)	了解 PCA 認證中心的運作機制	
9	13	三	波蘭	波蘭電力交易所(Towarowa Gielda Energii SA, TGE) 駐波蘭代表處	了解波蘭電力交易所於再生能源憑證之發展	

9	14	四	波蘭	化學物質局(Bureau for Chemical Substances, BCS)	了解化學物質局之業務發展與簽署 MoU	
9	15	五	波蘭	波蘭證券交易所	了解波蘭綠電憑證發展現況	
9	16	六	台灣		搭飛機回台灣	

參、參訪人員名單

表 2 參訪人員名單

姓名	單位	職稱	參與行程
劉明忠	經濟部標準檢驗局	局長	全程
謝翰璋	經濟部標準檢驗局	主任秘書	全程
吳佳璇	經濟部標準檢驗局憑證中心推動辦公室	專員	全程
郭沐鑫	經濟部標準檢驗局憑證中心推動辦公室	專員	全程
趙國樑	財團法人中國驗船中心	董事長	英國、德國
劉英如	財團法人中國驗船中心	執行長	英國、德國
程維淵	財團法人中國驗船中心	驗船師	英國、德國
蔡幸好	財團法人中國驗船中心	專員	英國、德國
左峻德	財團法人台灣經濟研究院	所長	英國、德國
張智傑	財團法人台灣經濟研究院	顧問	英國、德國
陳彥霖	財團法人台灣經濟研究院	組長	英國、德國
劉兆歡	財團法人台灣經濟研究院	組長	英國、德國
魏嘉民	財團法人金屬工業研究中心	副執行長	英國、德國
崔海平	財團法人金屬工業研究中心	處長	英國、德國
何鎮平	財團法人金屬工業研究中心	組長	英國、德國
張忠良	財團法人台灣大電力研究試驗中心	董事長	全程

張庭綱	財團法人台灣大電力研究試驗中心	專案經理	全程
李海清	財團法人台灣電子檢驗中心	執行長	全程
呂玉珍	財團法人台灣電子檢驗中心	課長	全程
林昀緯	財團法人台灣電子檢驗中心	組長	全程
周顯光	財團法人船舶暨海洋產業研發中心	處長	英國、德國
許景行	財團法人全國認證基金會	執行長	波蘭
陳元貞	財團法人全國認證基金會	處長	波蘭

肆、參訪紀要

一、9月4日（週一）

■ 拜會駐英國台北代表處經濟組

首站拜訪駐英國台北代表處經濟組，本局劉明忠局長向駐英國台北代表處經濟組簡介台灣再生能源憑證制度、國家再生能源憑證中心發展現況與第三方檢測驗證中心計畫推動現況，並說明此行預計於英國所簽署之合作備忘錄，包含與 Global Maritime、Green Giraffe、London Offshore Consultant（LOC）完成 MOU 簽署活動，以及拜訪英國碳信託公司（Carbon Trust）與碳揭露專案(Carbon Disclosure Project, CDP)；其中簽署 MOU 之機構皆為國際知名離岸風電第三方檢測驗證機構，期許能透過簽署 MOU 加強我國第三方檢測驗證計畫中離岸風電的檢測驗證能量。

駐英國台北代表處經濟組李組長表示根據 offshoreWIND. Biz 網站 106 年 6 月 8 日報導，英國皇家財產局(The Crown Estate)近日公布「2016 年離岸風力發電營運年度報告」(Offshore wind operational report, January-December 2016)，報告指出，英國此刻正在進行離岸風力發電機組建設高達 830 組，預計 2017 年底之前，將有 7 座離岸風力發電廠開始供電，離岸風力發電的建設數量創下自 2010 年以來的新高紀錄。這樣的趨勢與台灣積極發展離岸風力發電相類似，但英國發展離岸風電已有 10 年的經驗，此次本團前來英國參訪及簽屬合作備忘錄，實有助於台灣於離岸風電之開拓。

另外，李組長表示台灣為英國第 30 大貿易夥伴，亦為英國在亞洲地區之第 10 大貿易夥伴，希望藉由本次雙方合作，創造更多台英往來機會，構建雙贏局面。

表 3 拜訪駐英國代表處經濟組與會人員名單

姓名	單位	職稱
李聰貴	駐英國台北代表處經濟組	組長
許莉美	駐英國台北代表處經濟組	一等經濟秘書
謝志浩	駐英國台北代表處經濟組	二等經濟秘書

■ 拜會碳信託(Carbon Trust) 組織

英國碳信託公司 Carbon Trust 為 2001 年由英國政府設置的獨立公司，發展低碳經濟、減少二氧化碳排放量與發展商業低碳技術。近年來，除了行之有年的產品碳足跡認證標準與標章外，Carbon Trust 也積極發展其它環境相關標準，包括減碳(Carbon Trust Standard for Carbon)、水資源減量(Carbon Trust Standard for Water)以及廢棄物減量(Carbon Trust Standard for Waste)認證標準。

其於 2006 年所推出之碳減量標籤(Carbon Reduction Label)是全球最早推出的碳標籤，宗旨為推動轉型低碳經濟，加速企業轉型速度，及低碳技術商業化。2007 年 3 月，英國 Walkers 公司與 Carbon Trust 公司合作，於其洋芋片產品包裝上標示 CO₂ 排放，並以產品生命週期之概念，標示其各階段 CO₂ 排放量占比，此為國際碳標示(Carbon Labeling)之緣起。2008 年 2 月，Carbon Trust 擴大推動碳標章，對象包括 Testco、Dyson 與 Pepsico 等 20 家廠商、75 項商品。

首先，本局就台灣的再生能源憑證制度進行簡報，讓碳信託了解我國發展再生能源憑證之目的與未來規劃，進而說明台灣再生能源憑證交易市場與交易系統，以及如何讓台灣廠商透過再生能源憑證開拓國外商機。接著碳信託碳足跡認證部門副主管 Morgan Jones 向本局說明碳信託在 2015 年 10 月更推出供應鏈碳足跡認證標準(Carbon Trust Standard for Supply Chain)，協助品牌商更有效的量測、管理並減少供應鏈的碳排

放。截至 2015 年，已有 7 家英國知名企業取得供應鏈碳足跡認證。目前其主要工作內容為：(1)針對永續低碳經濟商機提供顧問服務；(2)計量和認證機構、產品和服務的環境足跡，持續推動碳標章；(3)幫助開發及部署低碳技術和解決方法(能源效率和再生能源)。

Carbon Trust 現在轉型為顧問公司，為任務導向的獨立專業機構，為企業、政府和公部門提供顧問服務，目前正在協助哥倫比亞政府規劃碳交易市場，合作企業包含三星、可口可樂。另外，Carbon Trust 有許多客戶非常在乎 CDP 指數的評比，因此 Carbon Trust 也幫忙客戶設置其 Science Based Targets。Carbon Trust 亦特地為了再生能源電力創造了一個標籤(如圖 1 所示)，該標籤表示該電力產品已被 Carbon Trust 驗證為 100%再生能源，並表示其電力排放係數為零，一般會顯示在電費帳單上。該標準僅提供給電力供應商作為電力排放係數之依據。該標籤已存在十年，並可與特定電力產品搭配及結合使用。



* 100% of the electricity supplied is renewable, backed by certificates of renewable energy guarantees of origin. Emission factor compliant with the GHG Protocol Scope 2 Guidance and to be used for the 'market-based method'.

圖 1 Carbon Trust 再生能源電力標籤

(資料來源：Carbon Trust)

Carbon Trust 的主要工作為審查檢驗電力供應商所提供的數據，確保客戶所使用的再生能源與其產品之準確性與其環境效益沒有被重複計算。考察團隊當時詢問 Carbon Trust 如何確保環境效益不被重複計算，但由於時間有限，Carbon Trust 表示，後續將提供有關其 REGOs 所遵循之規範與 Ofgem 的數據品質標準給台灣再生能源憑證團隊；另外，相關接洽與後續合作，將再提供聯繫方式給台灣再生能源憑證團隊。



圖 2 由本局謝翰璋主任秘書 (左五)率隊拜訪英國碳信託於會後合影留念

(由左至右依序為財團法人台灣經濟研究院陳彥霖組長、財團法人台灣經濟研究院張智傑顧問、英國碳信託離岸風電部門經理 Ms. Emilie Reeve、英國碳信託離岸風電部門經理 Mr. Jan Matthiesen、本局謝翰璋主任秘書、英國碳信託策略與創新部門經理 Mr. Tom Jennings、經濟部標準檢驗局憑證中心推動辦公室郭沐鑫專員、英國碳信託碳足跡認證部門副理 Morgan Jones、駐英國台北代表處經濟組謝志浩二等經濟秘書、碳信託策略與創新部門分析師翁文妤)

表 4 拜訪英國碳信託與會人員名單

姓名	單位	職稱
Tom Jennings	英國碳信託策略與創新部	經理
Emilie Reeve	英國碳信託離岸風電部	經理
Jan Matthiesen	英國碳信託離岸風電部	經理
Morgan Jones	英國碳信託碳足跡認證部	副理
翁文妤	碳信託策略與創新部	分析師
謝志浩	駐英國台北代表處經濟組	二等經濟秘書

■ 拜會碳揭露專案(Carbon Disclosure Project, CDP) 機構

碳揭露專案(Carbon Disclosure Project ; CDP)是一個獨立的非營利組織，總部位於英國倫敦，由百事可樂集團(Pepsi)、吉百利(Cadbury)、沃瑪特(Wal-Mart)等 534 個管理資產總額達 64 兆美元的投資機構與 60 個採購組織共同發起，透過邀請各大企業填寫 CDP 設計的問卷，公開企業溫室氣體排放量，以及處理氣候相關之投資風險和機會的因應策略報告。

目前全球已有 4,000 多家企業、將近全球 81% 的大型上市公司揭露其溫室氣體管理的相關資訊；其中所集結簽署支持的全球法人投資機構於 2003 至 2013 年成長將近 20 倍，累積至今達 722 家。目前該組織經由多年發展與資料蒐集，已獲得大量企業與氣候變遷的相關資料。CDP 自 2003 年發出第一份問卷邀請企業揭露其碳風險、機會與管理的資訊以來，一直扮演企業與投資人之間的資訊橋樑。

經由過去的努力，CDP 已成為全球企業最廣泛的碳、水、森林等相關自然資源管理的揭露系統，至今 CDP 更發展出多元的專案，包括：Climate Change、Carbon Action、

Water、Forests、Cities、Supply Chain。CDP 於 2013 年啟動 CDP Rebrand，將組織名稱「Carbon Disclosure Project」正式更名為「CDP」，並且以新的 LOGO 及紅色作為象徵 CDP 促進世界邁向永續的積極動能與決心。

此次參訪目的主要是向 CDP 介紹台灣再生能源憑證制度，以認識我國再生能源憑證發展現況及未來規劃，進而說明台灣再生能源憑證交易市場與系統，同時說明如何讓台灣廠商透過再生能源憑證找尋國外商機，與國際接軌。之後與 CDP 討論後續合作鏈結方式，藉由這個機會介紹台灣再生能源憑證(T-REC)的細節，CDP 表示能夠看到 T-REC 的進展與細節，對於 T-REC 的設計與國際上的做法相符感到雀躍。CDP 的問卷設計由技術總監 Mr. Pedro Faria 的團隊負責，CDP 同意將 T-REC 放進 CDP 的問卷中，可做為證明企業使用再生能源的選項。



圖 3 本局謝翰璋主任秘書(左四)率隊拜訪英國碳揭露技術總監 Mr. Pedro Faria(左三)於會後合影留念

(由左至右依序為財團法人台灣經濟研究院陳彥霖組長、碳揭露技術總監助理、英國碳揭露技術總監 Mr. Pedro Faria、本局謝翰璋主任秘書、財團法人台灣經濟研究院張智傑顧問、財團法人台灣經濟研究院劉兆歡組長、駐英國台北代表處經濟組謝志浩二等經濟秘書、經濟部標準檢驗局憑證中心推動辦公室郭沐鑫專員)

此外，CDP 將對 T-REC 做個案研究，未來將由憑證團隊提供台灣憑證制度相關的細節文件，CDP 將整理介紹台灣的制度，透過 CDP 本身的平台向國際介紹台灣的再生能源憑證制度。CDP 認為台灣的電網系統獨立，是一個單純且理想的系統，並讚賞台灣的憑證制度設計目的跟對象非常明確。

表 5 拜訪英國碳揭露與會人員名單

姓名	單位	職稱
Pedro Faria	英國碳揭露	技術總監
謝志浩	駐英國台北代表處經濟組	二等經濟秘書

二、9 月 5 日（週二）

■ 拜會 Global Maritime (GM) 並見證合作備忘錄簽署

GM 執行長 Egil Kvannli 介紹 GM 集團成立於 1979 年，為一家獨立的私人企業，目前全球共有 15 處辦公室，總員工數約有 300 人，參與的歐洲離岸風場計畫大多分布於北海及波羅地海，目前 6 個離岸計畫正在進行。公司成員大多為船員以及工程師，皆為專業並有豐富經驗之人士，很期待能藉由此次的合作備忘錄簽署，未來提供台灣更多服務。接著再由英國區域經理 Neil Walker 簡介 GM 提供之服務內容，GM 成立於 1979 年，由 HitecVision 握有多數股權，為一家獨立的私人企業，目前全球總員工數約有 300 人。GM 為一家專門提供海事、離岸工程、海運方面技術顧問的公司，其服務的範圍涵蓋了整個離岸風場專案的生命週期，從工程設計(Engineering & design)、建造(Construction)、第三方查證(Third party verification)、海事保證鑑定(Marine warranty surveying)、動態定位(Dynamic positioning)、安裝(Installation)、風險管理(Risk management)及離岸海事結構除役(Decommissioning)。Global Maritime 透過五大洲的區域中心及服務據點，服務範圍可達全世界所有地方。過去 Global Maritime 主要為服務

離岸石油及天然氣產業，包含鑽探、運輸、平台設計、施工等等項目。自 2000 年以來，離岸風力發電產業漸漸於歐洲嶄露頭角，Global Maritime 也開始將其服務對象擴大至離岸風場的開發商及承包商。

針對再生能源產業，Global Maritime 主要提供以下的服務項目：

- 保證服務(Warranty Services)－如：第三方查證及核准(3rd Party Verification & Approval)、海事擔保(Marine Assurance)、離岸船體資料庫檢查/一般海事文件檢查 (Offshore Vessel Inspection Database, OVID/Common Marine Inspection Document, CMID) Inspections...等。
- 設計諮詢(Design Consultancy)－如：新船體設計、船體升級專案、船體適用性研究、操作手冊...等。
- 結構分析(Structural Analysis)－如：一般結構分析與設計、特定場址評估、海固設計、疲勞分析...等。
- 整合管理(Integrity Management)－如：全生命週期成本研究、風險和狀態檢查、成活力研究、延役計畫...等。
- 動態定位(Dynamic Positioning)－動態定位能力評估、失效模式分析(Failure Modes and Effects Analysis, FMEA)、組員能力保證(Crew Competency Assurance)、船體動態定位手冊...等。
- 軟體(Software)－營運模擬、繫船分析、穩定性分析、根據客戶特定需求客製開發...等。
- 法律服務(Legal Services)－專家見證、租船契約、重件吊裝操作、離岸設計、離岸安裝調查...等。
- 海事操作(Marine Operations)－運送安裝研究、操作模擬、停工評估、海事協調等。
- 漂浮分析(Afloat Analysis)－穩定性分析、纜線布置分析、繫船分析與設計...等。
- 風險研究(Risk Studies)－同時操作、碰撞風險評估、危害辨識(HAZID)危害與可操作性(HAZOP)及安全案例...等。

發展離岸風電，為我國建立再生能源之重要政策，而如上所述，離岸風場專案的生命週期，涵蓋的範圍非常廣，牽涉相當多的細節，尤其就海事保證鑑定方面，更是目前國內發展離岸風電必須盡速建立之技術。有鑒於此，此行在本局的見證下，國內專業法人與 GM 簽署了合作備忘錄，期望在此合作備忘錄的基礎下，與具經驗豐富的 GM 共同合作，在台灣一同推展海事保證鑑定工作。(詳細資料參見附件)



圖 4 Global Maritime 與國內專業法人共同簽署合作備忘錄

(由左而右依序為財團法人台灣經濟研究院左峻德所長、財團法人金屬工業研究中心魏嘉民副執行長、財團法人中國驗船中心趙國樑董事長、Global Maritime 執行長 Egil Kvannli、本局劉明忠局長、財團法人台灣大電力研究試驗中心張忠良董事長、財團法人台灣電子檢驗中心李海清執行長)

表 6 拜訪 Global Maritime 與會人員名單

姓名	單位	職稱
Egil Kvannli	Global Maritime	執行長
Anna Keen	Global Maritime	亞太地區經理
Steven Foong	Global Maritime	亞太地區業務發展經理
Neil Walker	Global Maritime	英國區域經理

■ 拜會 Green Giraffe (GG) 並見證合作備忘錄簽署

Green Giraffe 成立於 2010 年，由一群經驗豐富的財務專家所組成，專注於可再生能源領域的專業諮詢服務領域。具備涉及 1 GW 以上太陽能光伏和 17 GW 以上風場專案經驗，是歐洲海上風電財務評估、投融資回收風險評估之佼佼者。在過去七年內參與過 80 件以上再生能源計畫，並協助不同計畫執行盡職調查，取得將近 150 億歐元的融資，其中參與協助離岸風場開發的相關經驗高達 40 件以上，為全球離岸風電顧問市場的主要領導者。

在德國漢堡、英國倫敦、法國巴黎以及荷蘭烏得勒支設有辦事處，並有 60 多名專業人員，擁有專案及結構性融資、合約管理、併購及法律人才，提供專業、高品質的顧問服務。此外，亦有參與陸域風場、離岸風場、太陽光電、生質能及地熱等能源開發計畫之豐富經驗。

在國內專業法人中，由財團法人台灣經濟研究院負責盡職調查(due diligence)的工作，Green Giraffe 在這方面具備豐富的經驗，此次在本局的見證下，財團法人台灣經濟研究院與 Green Giraffe 簽署了合作備忘錄，期望未來在國內風場開發的過程中，能藉由本次合作備忘錄的簽署，借重 Green Giraffe 於國際各地的風場專案財務盡職調查

的知識與經驗，與國內開發商及金融機構合作，透過國內實際風場，讓國內金融機構更清楚了解再生能源專案可能潛在之風險及規避方式，提高我國金融機構之投融资及核保意願，以協助我國再生能源開發。在台灣能有盡職調查的實績。此外除了風力發電，亦可就太陽光電及地熱發電之盡職調查，探討未來合作的可能性。



圖 5 Green Giraffe 的 Jérôme Guillet 總經理向大家說明 Green Giraffe 背景



圖 6 本局劉明忠局長致詞



圖 7 Green Giraffe 與財團法人台灣經濟研究院簽署 MoU

(由左至右分別是 Green Giraffe 總經理 Jérôme Guillet、本局劉明忠局長、財團法人台灣經濟研究院左峻德所長)

表 7 拜訪 Green Giraffe 與會人員名單

姓名	單位	職稱
Jérôme Guillet	Green Giraffe	總經理
William Jackson	Green Giraffe	顧問
Mikael Chapel	Green Giraffe	顧問
Elodie Colliard	Green Giraffe	顧問

■ 拜會駐英國台北代表處

駐英國台北代表處林永樂代表表示歡迎本團為發展台灣離岸風電至英國參訪，台灣與英國在人權促進、經濟自由化等面向之目標與理念十分相近，之前在代表處的努力下，透過法律程序將酒駕撞死送報生的英商林克穎引渡回台服刑。另外，為強化台灣與英國之交流，代表處促成英國將台灣納入「登記旅客快速通關計畫（Registered Traveller Service, RTS）」，開放符合資格台灣民眾申辦電子通關。

本局劉明忠局長向駐英代表處表達感激之意，感謝林代表撥冗熱情接待並詳細說明代表處工作內容，加上經濟組李聰貴組長與許莉美秘書協助下，本局此行順利與 Global Maritime、Green Giraffe、London Offshore Consultant 完成 MOU 簽署。訪問駐英國台北代表處時，恰逢英國下議院 Andrew Rosindell 議員前來拜會林代表，議員向來關心台灣相關議題，表示由衷期待台灣與英國未來有更多交流的機會。



圖 8 駐英國台北代表處向本團簡介代表處工作內容



圖 9 本局劉明忠局長(右)拜會林永樂代表(左) 巧遇 Andrew Rosindell 議員(中)

表 8 駐英國代表處與會人員名單

姓名	單位	職稱
林永樂	駐英國台北代表處	駐英代表
程祥雲	駐英國台北代表處	駐英副代表
李聰貴	駐英國台北代表處經濟組	組長
許莉美	駐英國台北代表處經濟組	一等經濟秘書
謝志浩	駐英國台北代表處經濟組	二等經濟秘書

三、9月6日(週三)

■ 參訪 E.ON 及 London Offshore Consultant (LOC) 並見證合作備忘錄簽署

Rampion 離岸風場位於英國索塞克斯郡(Sussex)，於倫敦南方，風場距離岸邊約 13 至 25 公里，水深大約 19 至 39 米，基礎形式為單樁(Monopile)，預計安裝 116 組 MHI Vestas V112 風力發電機組，總開發規模為 400MW，開發商為歐洲能源巨擘 E.ON 公司，目前正處於建造階段，預計於 2018 年正式商轉。原本規劃搭乘人員運輸船(Crew Transfer Vessel, CTV)，做近距離 Rampion 離岸風場的參訪，但因天候不佳無法出海，故經由 E.ON 的離岸風能發展經理 Giles Sibun、開發經理 Chris Tomlinson、工程經理 Naren Mistry 及業務發展經理 Burkhard Seif 的安排，利用位於基地的會議室，詳細介紹 Rampion 風場的開發過程以及成立專屬公司的經過，目前 Rampion 風場並非由 E.ON 公司單獨持有，但由 E.ON 公司負責整體營運與規畫。Rampion 離岸風場的基本資料如表 9：

表 9 Rampion 離岸風場基本資料表

開發商		E.ON
風場裝置容量		400.2 MW
專案成本		19 億歐元
風力機	風力機型號	MHI Vestas Offshore V112-3.45 MW
	風力機數量	116
	風力機高度	140 公尺
	輪轂高度	80 公尺
	葉片直徑	112 公尺
	基礎型式	單樁式(每個塔架重約 200 噸)
風場環境	面積	79 平方公里
	水深	19 公尺-39 公尺
	離岸距離	13 公里-25 公里
	併網點	400kV 新建之變電站，位於 Twineham
	電纜上岸點	East Worthing
輸出電纜 (Export Cables)	個數	2
	長度	19 公里&17 公里
	傳輸型式	HVAC
	電壓	150kV
陣列海纜 (Array Cables)	長度	142 公里
	傳輸型式	MVAC
	電壓	33kV
海上變電站	名稱	Rampion Substation
	基礎型式	管架式(Jacket)
	基礎重量	1050 噸

基礎尺寸	22.5m*18m*43m
平台重量	2000 噸
平台尺寸	38m*42.3m
變壓器個數	2
變壓器容量	240MVA
變壓比	33/150Kv
開關設備	33kV & 150kV GIS

Rampion 風場位於英國南部海岸，靠近觀光勝地布萊頓。E.ON 簡報分享開發過程遇到的問題以及技術管理經驗，從場址特性調查、海床地質調查開始，到如何配合避開古河道地型發展風場，陸域電纜的規劃路徑須穿越國家公園保護地，E.ON 開發團隊並利用特殊的施工工法，確保國家公園的土質沒有被破壞，因此順利通過環評。Rampion 離岸風場於 2010 年開始發展，於 2014 年 7 月 16 日，英國能源與氣候變遷部正式同意 Rampion 離岸風場計畫，也成為英國南海岸第一個離岸風場。

表 10 為 Rampion 風場規劃的開發時程表，陸上部分的工程(如：變電站、電纜線等)，於 2015 年開始執行，第一階段的變電站於 2015 年 6 月至 2016 年 12 月施工，而圖 10 為其餘第二階段至第十二階段陸上電纜路線圖，可看到其路徑從電纜線的上岸點 East Worthing 至 400kV 新建變電站的位置 Twineham。

而海上部分的工程(包含基礎安裝、電纜線施工、風力機安裝等)，從 2016 年開始執行。風場施工的範圍與風場內風力機、氣象塔、海上變電站的佈局如圖 11 所示，總共有 116 支風力機、一個氣象塔、一個海上變電站。而風場的陣列海纜每一串會有 8 至 10 支風力機，其佈局方式如圖 12 所示。



圖 10 陸上電纜路線圖

表 10 Rampion 離岸風場開發時程表

Indicative construction programme overview																				
	2015				2016				2017				2018							
	M	J	A	S	O	N	D	F	M	A	M	J	A	S	O	N	D	F	M	A
Milestones																				
Investment decision	■																			
Fully operational																				■
Substation (stage 1)																				
Civil and enabling works																				
Mechanical and electrical build																				
Commissioning																				
Cable route (stages 2-12)																				
Topsoil strip, duct installation and reinstatement																				
Four main horizontal directional drills (HDDs)																				
Cable pulling, jointing and commissioning																				
Offshore works																				
Foundation installation																				
Cable installation																				
Electrical installation																				
Turbine installation																				
Operation & Maintenance (O&M)																				
O&M base construction																				
Wind farm O&M activity																				

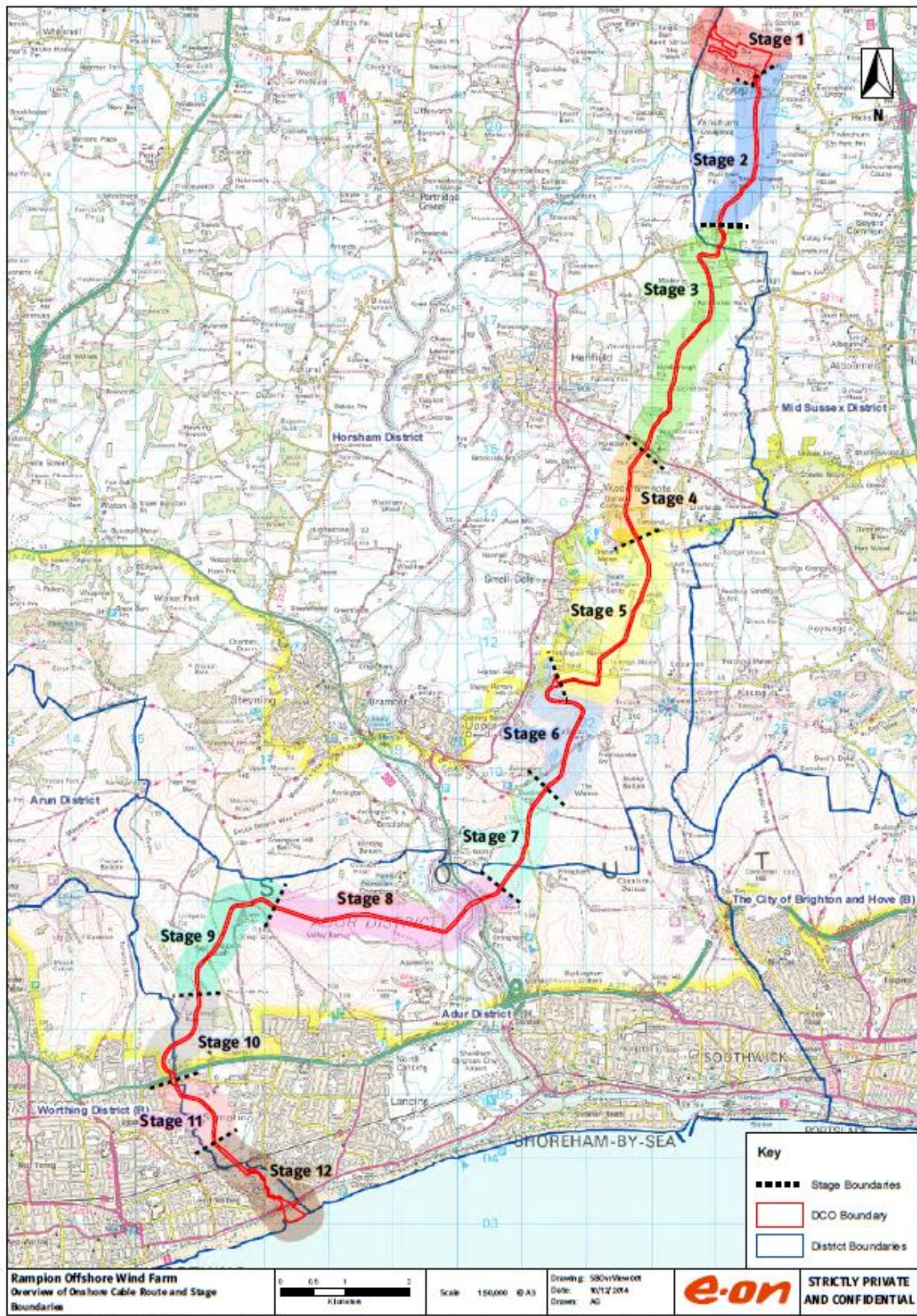

圖 11 Rampion 離岸風場佈局圖



圖 12 Rampion 離岸風場佈局與陣列海纜配置圖

LOC 於 Rampion 離岸風場開發中擔任海事保證鑑定(Marine Warranty Survey)的工作，公司成立於 1979 年，為全世界著名的離岸風場海事保證鑑定公司。LOC 目前於全世界 16 個國家有設立辦公室，為就近服務亞太地區之客戶，於亞太地區之 6 個國家共設有 13 個辦公室。整個 LOC Group 共有 375 位專職人員，由於 LOC Group 的核心技術為海事及工程顧問，因此員工由海員(Mariner)、海事工程師(Naval Architects)、結構工程師(Structure Engineers)、輪機員(Marine Engineers)等相關專業人士組成。

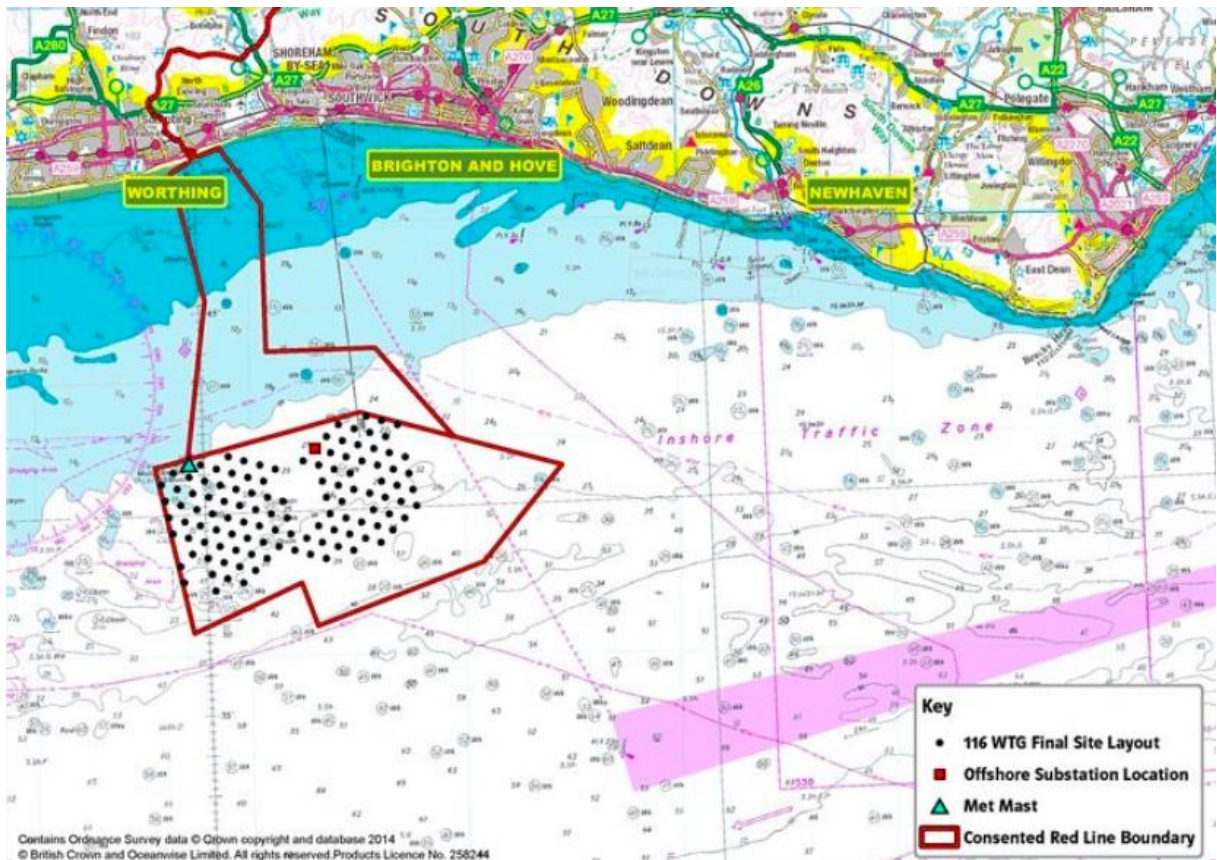
目前統計 LOC 已執行 60 個離岸風場專案之 MWS，協助安裝超過 9 GW 裝置容量，參與過之專案約占全球離岸風電之 65%，最高曾參與 8 MW 風機之安裝工程，總計執行過 2,061 組離岸風機之海事保證鑑定，在離岸風機基座部分也執行過 1,678 組單樁式(Monopile)安裝，以及 249 組衍架式結構。而在海底電纜部份，LOC 參與海事保證鑑定的鋪設長度超過 3,800 公里。總結 LOC 在海事保證鑑定的服務對象共遍布 14 個國家。綜觀 LOC 集團能力，可以服務離岸風場生命週期的所有海事工程顧問工作。而業務總監 R.V. Ahilan 也再次強調，LOC 目前為離岸風場海事保證鑑定的市場

領先者，大約 6 成的離岸風場海事保證鑑定皆委託 LOC 執行，另一方面 LOC 也與英國政府合作，參與部分離岸風場施工標準的制定過程，例如英國 Crown Estate 公布的自升式平台船最佳化操作指南(Jack-Up Vessel Optimisation)以及英國 RenewableUK 公布的離岸再生能源自升式平台船選擇與操作指南(Guidelines for the Selection and Operation of Jack-ups in the Marine Renewable Energy Industry)，LOC 也與離岸風場各承包商與開發商具有良好的合作關係。

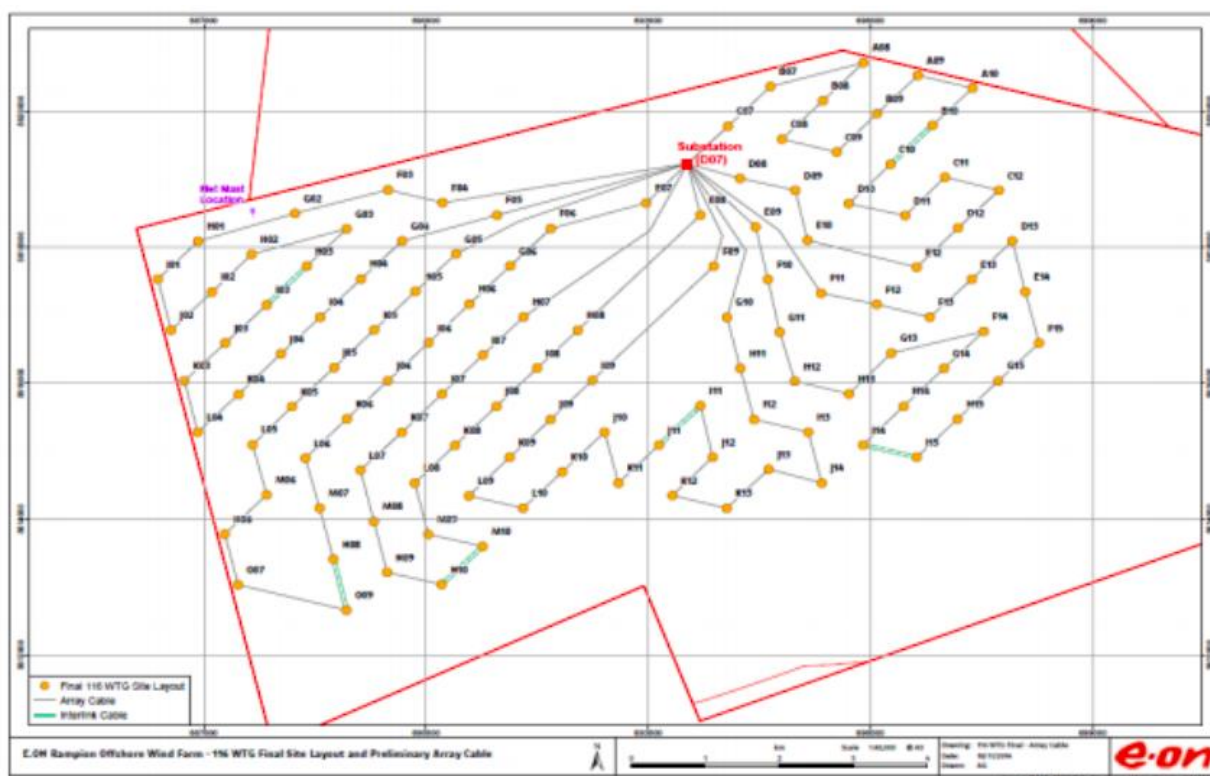

圖 13 Rampion 離岸風場計畫辦公室雙方交流



圖 14 Rampion 離岸風場協調中心

此次較可惜的是因海況不佳無法搭船在海上參觀風場，但 E.ON 帶參訪團進入協調中心(Coordinating Center)，如圖 14 所示，講解如何在控制室中透過監測螢幕，得知風場中各個作業船隻上的人員狀況，包括人員所受過的訓練履歷皆可得知。此外亦能透過得到的數據做出決策，有助於參訪團員了解未來台灣離岸風場工作時的安排作業。(詳細資料參見附件)

最後國內專業法人在劉明忠局長的見證下，與 LOC 簽署了合作備忘錄 MOU，期望能藉助 LOC 在全球豐富的海事保證鑑定之經驗，在台灣一同推動離岸風電的發展。至於與英國 LOC 公司推動海事保證鑑定驗證技術合作計劃共分為三階段：

1. 第一階段預計於 107 年開始由英國 LOC 公司提供教室訓練課程，讓國內專業法人充分了解國外執行海事保證鑑定的過程及注意事項。
2. 第二階段將由國內專業法人與英國 LOC 公司共同組成海事保證鑑定團隊，由英國 LOC 公司帶領團隊一同提供台灣離岸風場海事保證鑑定服務，透過這個過程將海事保證鑑定驗證能量轉移給國內專業法人，並將相關技術留在台灣。
3. 第三階段則為國內專業法人與英國 LOC 公司組成技術聯盟。以互相委託的方式一同拓展業務。



圖 15 LOC 與國內專業法人共同簽署合作備忘錄

(由左而右依序為台灣經濟研究院左峻德所長、中國驗船中心趙國樑董事長、本局劉明忠局長、LOC 執行長 Andrew Squire、台灣大電力研究試驗中心張忠良董事長、台灣電子檢驗中心李海清執行長)

表 11 拜訪 E.ON 及 LOC 與會人員名單

姓名	單位	職稱
Andrew Squire	LOC	執行長
Michael Frampton	LOC	業務長
R. V. Ahilan	LOC 再生能源技術諮詢部	總監
Kent Fong Wai Keong	LOC 離岸風電部門	總監
Emma Winsey	LOC 市場統籌部門	專員
Baiqian Jiang	LOC	海事工程師
Peter Croll	LOC	專案經理
Emily McGrath	LOC	專案行政人員
Giles Sibun	E.ON 離岸風能發展部	經理
Chris Tomlinson	E.ON 開發部	經理
Burkhard Seif	E.ON 商業發展部	經理
Naren Mistry	E.ON 工程部	經理

四、9月7日（週四）

■ 拜會 K2 Management (K2) 並見證合作備忘錄簽屬

K2 Management 由兩位擁有豐富風電開發經驗的 Lars K.Hammershøj 以及 Per K. Melgaard 成立於 2007 年，為一家獨立的顧問公司。在全球 10 個國家的據點共有超過 110 位員工。K2 協助客戶開發、建構、營運或投資風力發電，業務遍佈全球超過 35 個國家。

K2 自成立以來已參與了全球超過 1000 項的風電計畫，在其中主導了 178 項的陸域計畫 139 項的離岸計畫，主要提供的服務項目如下：

➤ 開發支援 Development Support

從風力分析到標案管理皆是其可提供支援的地方。好的風場專案管理從一開始的專案企劃即開始，跟合約策略有關的早期設計決策、承包商的選擇...等，都會大大的影響整個專案的結果。一但一個專案被許可，管理、監控等事項就變成風場專案成功的關鍵。

➤ 建造與安裝 Construction & Installation

當一個專案變得越來越大、越來越複雜，現場的組織與建造管理團隊的管理能力就變成專案成功的要件。而複雜的專案之開發及管理的兩大關鍵，就是風險(risk)與介面(interface)管理，兩者都需要有察覺潛在發生問題的能力、完全了解衝擊可能造成的結果、知道如何減少甚至消除這種風險所造成的衝擊。

➤ 資產管理 Asset Management

資產管理就是要做到在整個風場的生命週期中，盡可能有最佳的投資回報。若僅是單獨靠與風力機供應商在運作的期間的服務協議，大概只能使得風力機維持在基本層級的運作，如果沒有獨立的最佳化建議，將無法使報酬最佳化。

➤ 盡職調查 Due Diligence

再生能源的投資現在是主流，然而也需要全球金融保險相關單位持續的投資，才能讓全球的風力事業持續成長。盡職調查即是藉由專業的風力評估技術，並考慮

風機擾流及地形等因素後，計算風場的發電量，量化風場的價值以取得銀行對於專案還款能力的信心，藉以能持續推動離岸風力的發展。

此次在漢堡的會面的人士，包括了 K2 共同創辦人 Lars K.Hammershøj、執行長 Henrik Stamer 以及總經理 Axel Juhnke。由於 K2 在 2005 年就直接參與了台灣 Formosa (海洋風場) 第一期的計畫，擔任開發商的顧問，負責風資源的評估，並規劃整體的計畫和風險管理、設計諮詢和採購招標，確保開發商能成功地完成融資，所以與台灣已有相當的合作基礎。為了能持續深耕台灣離岸風電第三方驗證的技術能力，K2 特別安排於漢堡海事博物館(Maritime Museum)進行合作備忘錄簽署地點，由財團法人中國驗船中心及財團法人台灣經濟研究院為代表，在本局劉明忠局長的見證下，與 K2 完成簽署儀式。藉由 K2 已有多次成功協助完成融資的相關經驗，與其進行技術合作，先由室內的訓練課程簡要的介紹技術盡職調查的流程架構，藉由 K2 過去的案例，模擬流程反覆地進行練習，並在未來搭配實際案例進行實際的演練，以快速建立盡職調查技術能力。



圖 16 K2 與國內專業法人共同簽署合作備忘錄

(由左至右依序為財團法人中國驗船中心趙國樑董事長、K2 執行長 Henrik Stamer 先生、本局劉明忠局長、財團法人台灣經濟研究院左峻德所長)

圖 17 為本局劉明忠局長與財團法人中國驗船中心趙國樑董事長於簽署合作備忘錄前的致詞。圖 18 為 K2 執行長 Henrik Stamer 先生說明 K2 業務與台經院劉兆歡組長進行簡報說明。



圖 17 本局劉明忠局長(左)與中國驗船中心趙國樑董事長(右)致詞



圖 18 K2 執行長 Henrik Stamer 先生(左)與台經院劉兆歡組長(右)簡報說明

表 12 拜訪 K2 與會人員名單

姓名	單位	職稱
Lars K.Hammershøj	K2	創辦人
Henrik Stamer	K2	執行長
Axel Juhnke	K2	總經理

■ 拜會德國 Fraunhofer IWES 風力機機艙動力鏈測試實驗室

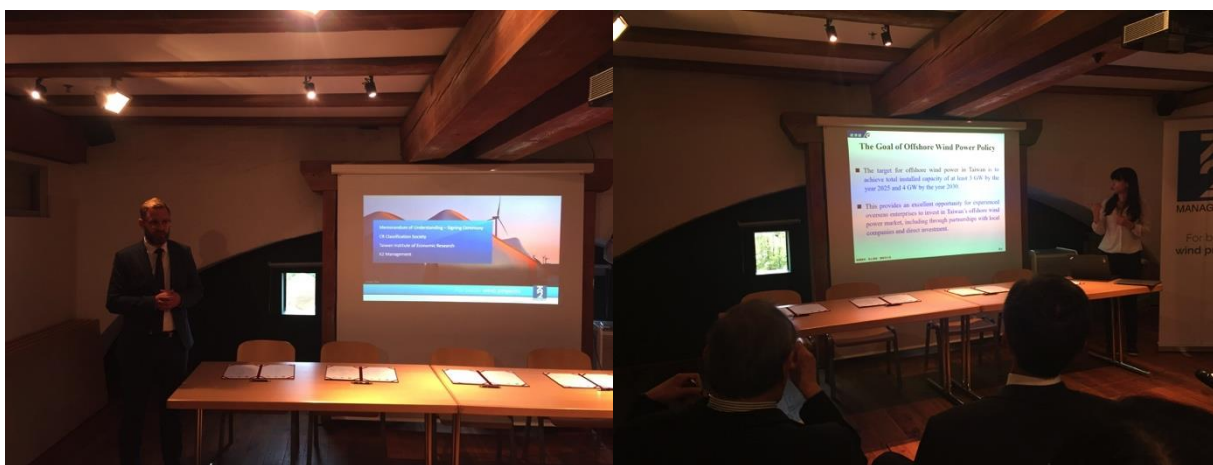
9 月 7 日由本局謝翰璋主任秘書帶領金屬工業研究發展中心風力機機艙動力鏈測試實驗室規劃小組成員及財團法人台灣經濟研究院張智傑顧問共 6 人赴 Fraunhofer IWES 風力機機艙動力鏈測試實驗室參訪，與 Fraunhofer IWES 公司技術部門經理 Torben Jersch 及 Fraunhofer IWES 機艙動力鏈測試實驗室之建置廠商 Idom 公司及 ABB 公司人員針對風力機機艙動力鏈測試實驗室建置之技術規格、實驗室之空間需求、實驗室運維等問題進行研討，學習 Fraunhofer IWES 實驗室建置經驗，並針對國內目前正規劃建置之風力機機艙動力鏈測試之規格做深入的討論，做為國內建置此實驗室之參考。

Fraunhofer IWES 公司全名為 Fraunhofer Institute for Wind Energy and Energy System Technology，位於德國布萊梅港，所從事的研究範圍包含整個能源系統之研究開發，其內容包括風力發電機組及風力發電場之技術和運維、風力發電機組及其零組件動力學、風力發電機機艙組動力鏈等核心組件的設計研發、風力發電機組及其核心零組件的性能測試和評估、風力和海洋環境資源評估、能源管理、能源供應結構和系統分析。

Fraunhofer IWES 作為風電領域國際頂尖的研究機構，擁有先進的風力機機艙組動力測試平台，此測試平台於 2015 年建置完成，設備總建置費用約 3,500 萬歐元，由

德國聯邦政府補助 1,850 萬歐元，實驗室剛成立時有 6 個工程師目前該實驗室有 24 個工程師。設備之主要規格如下:

- Force application: dynamic application of 20 MNm bending moment, ca. 2 MN thrust forces

- Dynamic 0-2 Hz

- Motor : 2 x 5 MW continuous power

Nominal torque: 8,6 MNm

Motor speed: ± 25 rpm

Overload torque: 13 MNm

- Artificial network with 40 MVA installed inverter power

- Measurements: more than 600 synchronous, high resolution measuring channels

Gridsimulator Based on 4x ABB ACS6000 Gridsimulator Based on 4x ABB ACS6000

- Grid load simulation : LVRT & HVRT

- Nominal voltage level :

Nominal tapping: 10 kV - 20 kV - 36 kV

HVRT tapping: 13 kV - 26 kV - 46.8 kV

LVRT capability: to 0V

此測試系統可以執行之測試核心項目包括：機艙組之組裝完成測試、研發及最佳化測試、設計驗證/分析、電網模擬測試、風力機變流器之驗證測試。

(詳細資料參見附件)



圖 19 IWES Nacelle測試場佈置示意圖(IWES資料圖片)



圖 20 IWES Nacelle測試場待測物移載設備

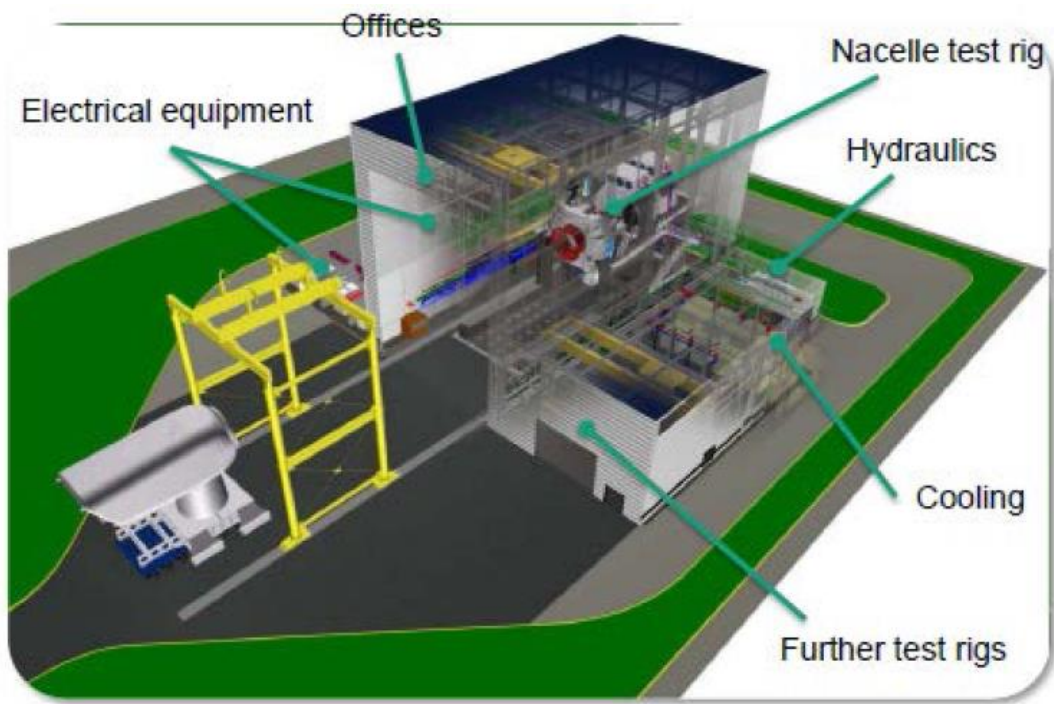

圖 21 IWES Nacelle測試場設備安裝(IWES資料圖片)

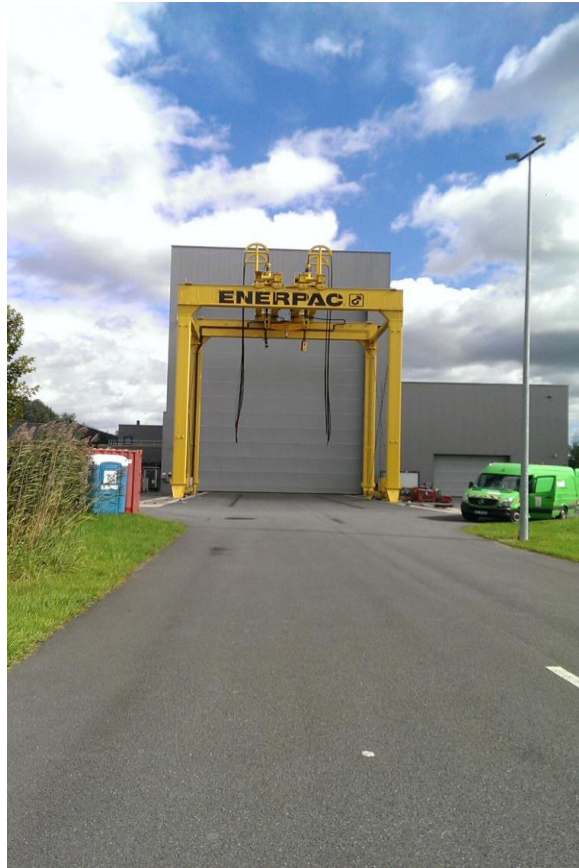

圖 22 IWES Nacelle動力鏈測試設備 (IWES資料圖片)



圖 23 IWES Nacelle動力鏈測試設備內部構造



圖 24 Fraunhofer技術部門經理Torben Jersch介紹動力鏈測試系統構造

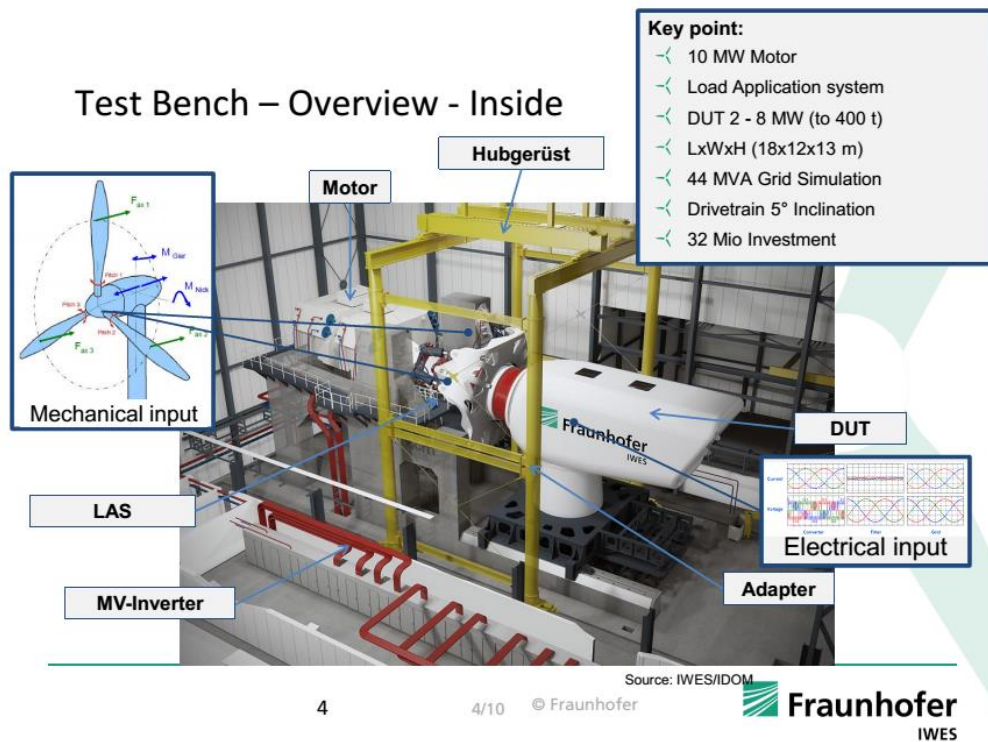

圖 25 與Idom公司討論國內規劃之機艙動力鏈測試系統規格



圖 26 參訪團與Fraunhofer、Idom公司及ABB公司人員合影

(由左至右依序為財團法人台灣經濟研究院張智傑顧問、財團法人金屬工業研究中心魏嘉民副執行長、本局謝翰璋主任秘書、財團法人金屬工業研究中心何鎮平組長、ABB公司特殊應用經理 Kai Pietilaeinen、財團法人金屬工業研究中心崔海平處長、ABB公司全球產品經理 Ester Guidi、IDOM公司 Dr. Armando Bilbao、Fraunhofer 技術部門經理 Torben Jersch)

表 13 拜訪 Fraunhofer 與會人員名單

姓名	單位	職稱
Torben Jersch	Fraunhofer 技術部	經理
Kai Pietilaeinen	ABB 特殊應用部	經理
Ester Guidi	ABB 全球產品部	經理
Armando Bilbao	IDOM 先進設計與分析部	博士

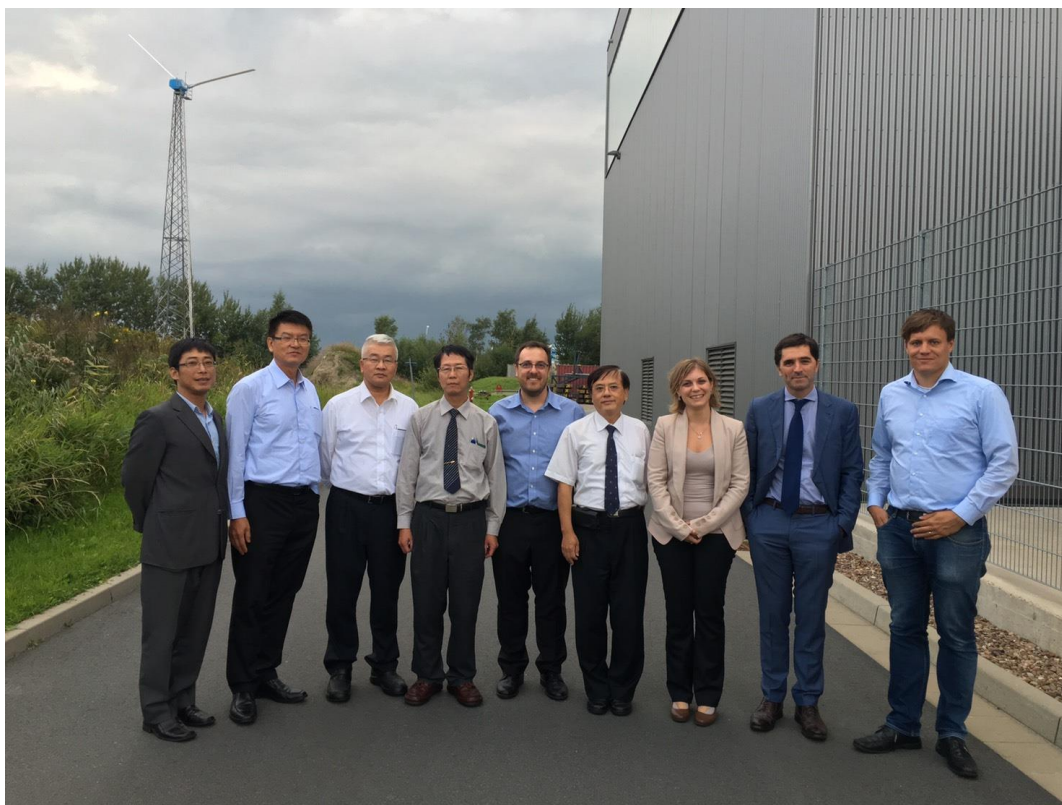
五、9月8日（週五）

■ 拜會德國海事局(Bundesamt für Seeschifffahrt und Hydrographie, BSH)

BSH 其總部位於漢堡，為負責德國專屬經濟海域(Exclusive Economic Zone, EEZ)開發主管機關。故在德國北海及波羅的海地區內的離岸風能申請程序與核准，都是由 BSH 負責。

BSH 針對核准離岸風能的流程，於其官網上公佈了四份標準：

1. Minimum requirements concerning the constructive design of offshore structures within the Exclusive Economic Zone (EEZ), 2015.
2. Ground Investigation for offshore wind energy, 2014.
3. Design of Offshore Wind Turbines, 2007.
4. The 3rd update of the German version of the “Standard for Environmental Impact Assessment”, 2013.

BSH 與專家們一起合作，規定了風電場地強制性地質/地球物理和岩土工程現場調查的詳細最低要求，離岸風力機建設要求以確保所有設計都有符合安全需求。而上面這四份標準包含了離岸風力機的設計、環境衝擊的研究、離岸風場的調查、專屬經濟海域之離岸建造設計的最低要求。在2001年11月9日 BSH 首次核准了 German Bight 中 12 支離岸風力機的建造及營運，這個風場也就是後來的 alpha ventus，其也是用來測試在海洋中發電所造成的衝擊。

首先是 BSH 的局長在百忙之中特地致歡迎詞(如圖 27)。而在會議中，台德雙方也有相當多討論的議題，本局劉明忠局長針對台灣海峽有白海豚的議題向 BSH 詢問，其在周邊海域開發離岸風場時，是否也有遇到海洋生態保育的問題。對此問題，Dr. Nico Nolte 提到，針對施工工法，會採用減少噪音的方式，以減少對海中生物的影響。而有些生物則會主動避開離岸風場 2~4 公里的距離，所以他們也會做非常詳盡的環境影響評估，了解各海域的生物數量，以決定各個區域合理的離岸風場開發數量，才能對海中生物的影響降到最低。



圖 27 BSH 局長 Monika Breuch-Moritz (站立者)致詞

除役問題也是大家很關心的事項，例如除役保證金要交多少、準備多少？以及每年是否需要第三方進行檢驗？BSH 表示除役的規畫在剛開始的專案驗證就會事先納入評估事項，不僅針對離岸風場的生命週期為基準，風場中的風力機、基礎建設的狀況都會影響是否申請延役。另外 BSH 也會要求風場開發商每年都要進行第三方檢驗，以確保離岸風場的營運。



圖 28 Dr. Nico Nolte(左一)、劉明忠局長(中)以及 Dr. Manfred Zeiler(右一)

從與 BSH 的交流，可以了解到德國在離岸風場相關的經驗，從專案開始的環境評估，到風場的除役規畫，很多都是需要溝通協調與多方考量，台灣之後在規劃離岸風場專案，也需要依據實際的狀況調整，以符合我們當地的情況。(詳細資料參見附件)

表 14 拜訪 BSH 與會人員名單

姓名	單位	職稱
Monika Breuch-Moritz	BSH	局長
Mantred Zeiler	BSH	博士
Nico Nolte	BSH	博士

■ 拜會駐德國台北代表處

駐德國漢堡辦事處沈文強處長親自接待，首先聽取本局與國內專業法人於此行的目地、成果與國內執行狀況。沈處長表示台德交流一直都很緊密，並提到漢莎同盟，漢莎一詞來自哥特語「軍隊」，在德語中原意為「堆集」，後來引伸為同業公會或行會，在其全盛時期，漢莎同盟左右著丹麥和瑞典的王位繼承人人選，而英國國王甚至不止一次將王冠抵押給漢莎商人換取貸款，或向其央借艦隊和海員。處長以此為例，讚許本團國內專業法人集合台灣最精英單位，為了協助台灣發展離岸風力發電，至德國鏈結潛力合作夥伴及學習，期許本團發揮團隊精神，大家貢獻所長，加速台灣能源轉型。

本局劉局長表示感謝沈處長協助，亦感謝在駐德國代表處經濟組何元奎組長及何子毅秘書的協助下，順利造訪德國聯邦海事局、K2、DEWI-OCC、TÜV SÜD、DNV GL，奠定我國離岸風電第三方驗證的基礎，一步一腳印實現驗證在地化的長期目標。



圖 29 本局劉明忠局長(右)致謝駐德國漢堡辦事處沈文強處長(左)

表 15 拜訪駐德國漢堡辦事處與會人員名單

姓名	單位	職稱
沈文強	駐德國台北代表處漢堡辦事處	處長
黃庭芸	駐德國台北代表處漢堡辦事處	秘書
何元圭	駐德國代表處經濟組	組長
何子毅	駐德國代表處經濟組	經濟秘書

■ 拜會 DEWI Offshore Certificate Center GmbH (DEWI OCC) 並見證合作備忘錄簽屬

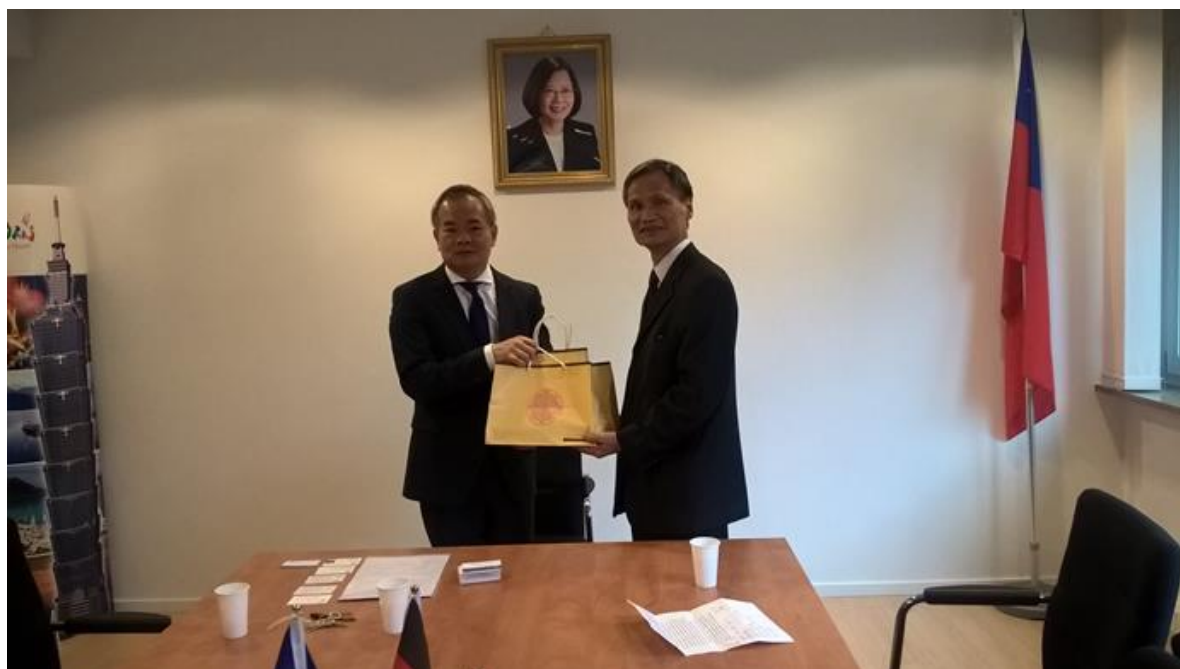
DEWI OCC 成立於 2003 年，位於德國庫克斯港，在全球被公認在離岸風力機以及風力機組件的領先驗證單位之一。DEWI OCC 由德國國家認證機構-DAkkS 所認證，並在全球有超過 70 名員工，分別遍佈德國、印度、美國、南韓、中國以及日本等，

提供離岸以及陸域的相關驗證服務，並於 2012 與 UL 合併成為其公司之一。

UL 成立於 1894 年，擁有超過 120 年驗證經驗的公司，也是美國驗證領域市占率最高的公司，其服務範圍跨及各領域，包含通訊系統、電機產品以及建築業等，在全球擁有一萬兩千名員工、四十個據點，除了 DEWI OCC 以外也另外收購 AWS True power(擁有再生能源融資經驗逾 30 年)，企圖為客戶打造全方位的服務。

主要提供的工作項目如下：

- 渦輪機或部件認證(Certification of Turbine or Components)
- 建築與基礎評估(Assessment of Construction and Foundation)
- 專案驗證(Project Certification)
- 損傷分析(Damage analysis)
- 運輸及架設監控(Transport and erection surveillance)
- 技術盡職調查(Technical Due Diligence)
- 財務盡職調查(Financial Due Diligence)

為確保離岸風場設置之安全性，並提供可信賴之技術評估供我國金融及保險業者作為專案融資貸款及保險之風險管理依據，盡職調查和專案驗證為其中的重要工作，DEWI OCC 為少數受德國海事局以及德國認證機構 DAkkS 認可之驗證單位，能夠執行離岸風場專案驗證的公司。

另外本局為推動國內離岸風場產業發展，希望藉由促成國內專業法人與 DEWI-OCC 完成 MOU 的簽署，共同籌組第三方驗證團隊，期望利用團隊技術能力，提供銀行與投資人可靠及可信賴之技術盡職調查報告，作為專案融資貸款及保險之風險管理依據，增加國內金融產業參與的意願與能力，以此方式完整離岸風電之產業體系，進而協助達成我國於 114 年離岸風電總裝置容量 3,000 MW 之目標，促進我國再生能源發展。



圖 30 國內專業法人與 DEWI-OCC 完成 MOU 簽署

(左起為財團法人金屬工業研究發展中心魏嘉民副執行長、財團法人台灣電子檢驗中心李海清執行長、財團法人中國驗船中心趙國樑董事長、本局劉明忠局長、DEWI-OCC 總經理 Hergen Bolte、財團法人台灣大電力研究試驗中心張忠良董事長、財團法人台灣經濟研究院左峻德所長)

本次與 DEWI-OCC 之合作協議，內容針對風電產業測試認證技術的合作，包括從建置風場的地質調查研究、風場開發、建構施工、營運分析，甚至後續的測試認證等，也將增加台灣產業對風電的專業知識，促進國內風能產業的品質、安全度和可靠性，並提高國內的相關評估能力。其中技術盡職調查已開始針對實際商業案例(中華電信陸域風場開發案)洽談合作。未來若是由 DEWI-OCC 獲得台電離岸風場專案驗證合約，亦可透過雙邊合作模式，由國內專業法人與 DEWI-OCC 一同合作執行專案驗證。DEWI-OCC 認為，台灣具有地理優勢，擁有全球少見的高品質風力發電場域，希望能分享德國的風能經驗，協助台灣技術發展，推動實際案場、實作建置的本土認證技術，以減少國內離岸風電專案認證費用，進一步建立起第三方檢驗中心的認證評鑑制度，亦盼能藉此合作，讓台灣有機會成為亞洲離岸風電的先驅。圖 31 為本局劉明忠局長於簽署合作備忘錄後，與 DEWI-OCC 總經理 Hergen Bolte 互贈禮物留念。



圖 31 簽署合作備忘錄後雙方互贈禮物留念

(由左至右為台灣電子檢驗中心李海清執行長、中國驗船中心趙國樑董事長、本局劉明忠局長、DEWI-OCC 總經理 Hergen Bolte、DEWI-OCC 可再生產品與組件部門 Holger Soker 部長、財團法人台灣經濟研究院左峻德所長)

表 16 DEWI-OCC 與會人員名單

姓名	單位	職稱
Hergen Bolte	DEWI-OCC	總經理
Holger Soker	DEWI-OCC 可再生產品與組件部	部長
Albert Kriener	DEWI-OCC 全球離岸風電部	部長
Thomas Neumann	DEWI-OCC 研發部	部長
Tees Nachtigall	DEWI-OCC 全球離岸風電部	業務發展經理
宋瑞義	優力國際安全認證有限公司	協理

六、9月11日（週一）

■ 拜會南德意志集團(TÜ V SÜ D) 並見證合作備忘錄簽署

TÜ V 南德意志集團是專業測試、檢驗、審核、驗證，培訓和知識服務解決方案獨立第三方驗證單位，總部在德國的慕尼黑，是 TÜ V 組織的成員之一。TÜ V SÜ D Taiwan 於 1992 成立。TÜ V SÜ D Industry Service 工業服務是位於德國慕尼黑 TÜ V SÜ D 集團的一個子公司，1994 年導入風能驗證服務，2008 年新增風場評估及風場專案驗證，2010 年在漢堡成立離岸風能部門，全力發展離岸風能相關驗證服務。目前 TÜ V SÜ D 為依據 DIN EN ISO/IEC 17065 標準通過德國認證機構 (DAkkS) 認可的驗證機構，同時也被德國聯邦海事與水文局 (BSH)、丹麥認可為離岸風電場專案驗證的驗證機構。可依 IEC 國際標準及德國聯邦海事與水文局 (BSH) 執行離岸風場專案驗證，確保風場投資者在設計及施工階段確實遵守法規規定。

此外，TÜ V SÜ D 集團擁有國際認證的風力評估測試實驗室，在離岸風電領域內，

TÜ V SÜ D 集團提供測試、產品和專案驗證、檢查、審核、知識服務和訓練。為配合政府政策及國內風力機產業發展，歷經幾年來自於 TÜ V SÜ D 的技術移轉，已由標準檢驗局及金屬中心建立離岸風力機相關標準法規、以及離岸風力機整機測試技術，並於 2016 年 8 月見證測試實驗室的開幕與授證。

故本次在本局劉明忠局長的帶領下，國內專業法人與 TÜ V SÜ D 簽署了合作備忘錄。(如圖 32 由左至右依序為台灣大電力研究試驗中心張忠良董事長、台灣電子檢驗中心李海清執行長、金屬工業研究發展中心魏嘉民副執行長、本局劉明忠局長、TÜ V SÜ D 集團總裁 Ferdinand Neuwieser、中國驗船中心趙國樑董事長、台經院左俊德所長)

除整機的測試驗證外，希望藉由本次合作備忘錄的簽署，借重 TÜ V SÜ D 於國際各地的風場專案驗證的知識與經驗，提供國內單位驗證風力機設計條件與風場場址評估，確認離岸風力機及風場可符合於台灣環境，TÜ V SÜ D 日後將可派遣技術專家提供專案驗證知識服務和訓練，協助台灣發展離岸風能及風場驗證技術，以及標準檢驗局即將負責建立的「第三方驗證機構」，目的為於風能產業上建立雙方合作關係，達到：增加風能產業之專業知識，以及確保風能產業之品質、安全性及可靠性的目標。幫助台灣金融、保險等相關業者，瞭解離岸風場開發及相關經濟鏈，健全整體產業、增加就業人口，提高減碳成效和達成環境永續。



圖 32 國內專業法人與 TÜ V SÜ D 簽署 MOU

(由左至右依序為台灣大電力研究試驗中心張忠良董事長、台灣電子檢驗中心李海清執行長、金屬工業研究發展中心魏嘉民副執行長、本局劉明忠局長、TÜ V SÜ D 集團總裁 Ferdinand Neuwieser、中國驗船中心趙國樑董事長、台經院左俊德所長)

表 17 拜訪 TÜ V SÜ D 與會人員名單

姓名	單位	職稱
Ferdinand Neuwieser	TÜ V SÜ D	總裁
Alexander Heitmann	TÜ V SÜ D 離岸風電部	部長
Malte Lossin	TÜ V SÜ D 離岸風電部	技術經理
林建秋	TÜ V SÜ D	台灣區總經理
王鉅翔	TÜ V SÜ D	台灣區技術經理

■ 拜會立恩威集團(DNV GL) 並見證合作備忘錄簽署

DNV 挪威驗船協會成立於 1864 年，而 GL 為德國驗船協會成立於 1867 年，兩驗船協會成立之初都是為了確保海上船隻與人命安全，建立一套統一的規範和程序用於評估船舶保險的風險提供可靠且統一的評級和課稅。

DNV 與 GL 與 2013 年合併，成為目前全世界最大的離岸風場相關測試驗證與技術服務公司。合併後整體 DNVGL 集團於全球共有超過 13,000 名員工，分布於 100 個國家，與離岸風力發電相關的能源(Energy)部門與全球亦有 2,300 名員工。服務項目包含離岸風場專案驗證、海事保證監督、工程盡職調查。DNV GL 為全球風場驗證市占率第一的驗證單位，在海事工程方面亦有相當多的經驗值得學習。

因應 2025 年非核家園政策，台灣將陸續開發大規模的離岸風場，然而離岸風場建置經費龐大，為確保離岸風場於生命年限內之運轉品質及降低風場周圍之環境影響，並降低金融業者放款風險，應導入離岸風場專案驗證機制，針對設計準則評估、設計評估、製造檢驗、安裝檢驗及試運轉檢驗，將離岸風場建置風險降至最低。

依據德國交通運輸部(Ministry of Transport)規定，將風能主管機關指定為德國海事局(BSH)，德國海事局強制性要求位於德國領海的離岸風場需執行完整的專案驗證，其中 DNV GL 即為德國海事局授權的離岸風場專案驗證第三方驗證單位之一，除了德國之外，DNV GL 亦於全球其他國家累積許多離岸風場專案驗證實績。

在本局劉明忠局長的見證下，中國驗船中心、台灣大電力研究試驗中心、金屬工業研究發展中心、台灣電子檢驗中心及台灣經濟研究院，與 DNV GL 副總裁 Kim Mørk 簽訂合作備忘錄，此次合作以風力發電機安全性、可靠性以及性能驗證等面向合作，希望藉由此次機會，建立台灣離岸風場專案驗證能量，以滿足台灣風場開發時相關驗證及技術盡職調查之需求，進而帶動台灣離岸風電產業之發展。(詳細資料參見附件)



圖 33 DNV GL 副總裁 Kim Mørk 致詞



圖 34 與 DNV GL 簽訂合作備忘錄

(由左起依序為金屬工業研究發展中心魏嘉民副執行長、台灣電子檢驗中心李海清執行長、財團法人台灣經濟研究院左峻德所長、本局劉明忠局長、DNV GL 副總裁 Kim Mørk、中國驗船中心趙國樑董事長、台灣大電力研究試驗中心張忠良董事長)

表 18 拜訪 DNVGL 與會人員名單

姓名	單位	職稱
Kim Mørk	DNVGL	副總裁
Fabio Pollicino	DNVGL 全球再生能源認證服務部	部長
Steffen Haupt	DNVGL 再生能源認證部	部長
Bjornp-Olaf Borth	DNVGL	德國與澳洲區董事長
Per Enggaard	DNVGL 再生能源認證部	亞太地區經理

七、9月12日（週二）

■ 拜會波蘭認證中心(Polish Centre for Accreditation, PCA)

波蘭認證中心(Polish Centre for Accreditation, 以下簡稱 PCA)係屬政府編制部門，是波蘭的國家認證機構(National Accreditation Body)，其前身為波蘭測試驗證中心之認證辦公室(Accreditation Office of the Polish Centre for Testing and Certification)及量測中央辦公室之校正實驗室認證部(Calibration Laboratories' Accreditation Department of the Central Office of Measures)。現在是基於以下的波蘭法案及歐盟規範，進行認可符合性評鑑機構(Conformity assessments bodies, CAB)的工作，認證對象包含執行測試與校正的實驗室、檢驗機構、管理系統驗證機構、產品驗證機構、能力試驗執行機構等。

- ✓ Act of Parliament of 13 April 2016 on conformity assessment systems and market surveillance (Journal of Laws of 2016, item 542)
- ✓ Regulation (EC) No 765/2008

而相對應的財團法人全國認證基金會(Taiwan Accreditation Foundation，以下簡稱 TAF)為我國的認證(accreditation)機構。於國際角度而言，PCA 及 TAF 同為國際實驗室認證聯盟(International Laboratory Accreditation Cooperation，以下簡稱 ILAC)及國際認證論壇(International Accreditation Forum，以下簡稱 IAF)之正會員(Full Members)，並皆簽署 ILAC 與 IAF 相關認證領域之國際相互承認協議(Mutual Recognition Arrangement，簡稱 MRA 或 Multilateral Recognition Agreement，簡稱 MLA)，例如測試、檢驗、校正、產品、管理系統等。

台灣廠商的產品若要進入歐盟，其產品需要有 CE 證書才行，目前有如下幾種類型的 CE 證書：

- (1) Declaration of conformity / Declaration of compliance 《符合性聲明書》，此證書屬於自我聲明書，不應由第三方機構（仲介或測試驗證機構）簽發，因此，可以用歐盟格式的企業《符合性聲明書》代替。
- (2) Certificate of compliance / Certificate of compliance 《符合性證書》，此為第三方機構（仲介或測試驗證機構）頒發的符合性聲明，必須附有測試報告等技術資料 TCF，同時，企業也要簽署《符合性聲明書》。
- (3) EC Attestation of conformity 《歐盟標準符合性證明書》，此為歐盟公告機構（Notified Body 簡寫為 NB）頒發的證書，按照歐盟法規，只有 NB 才有資格頒發 EC Type 的 CE 聲明。

針對驗證機構，可分為下面三類：

第一類驗證機構：國外權威機構，歐盟的公告機構，可以頒發 EC Attestation of conformity 《歐盟標準符合性證明書》（上述第三種）。產品如果取得了這種由歐盟公告機構（Notified Body 簡寫為 NB）測試和出具的證書，則企業不需要簽發《自我聲明書》，由“指定機構”對產品符合性承擔責任，受法律保護。因此，對於歐盟公告機構（Notified Body 簡寫為 NB）頒發的 CE 證書，不存在判定有效性的問題。對於產品出口通關，這一類的檢測機構出具的報告最為有效。對於這類機構，如果其在國內有檢測實驗室，則可以在國內進行產品的測試，否則產品的測試需要運送到國外進行。

這種證書所需的費用高、時間長，但是被認可的程度高。

第二類驗證機構：國內測試機構同歐盟的公告機構合作的合資公司，這類機構依然可以如第一類驗證機構一樣，能夠頒發具有 NB 號的 EC Type 證書。一般情況下，這類 CE 認證的測試工作都在國內的合資實驗室進行。這種證書的被認可程度同第一類。

第三類驗證機構：由國內任何具有技術能力的實驗室進行檢測和頒發該實驗室的 CE 證書（上述第二種），費用低時間也相對少。但是，對於沒有獲得歐洲實驗室資格認可的實驗室出具的 CE 報告或證書獲歐盟經銷商的認可程度低，經常有不被進口商接受或不被管理機構認可的情況發生。

是故對於台灣本地的實驗室，若能成為 NB，對於台灣的廠商將是一大福音，因為其產品只需經過台灣的實驗室檢測並出具 CE 證書，此證書被歐盟當地經銷商採用的程度將大幅提升，產品進入歐洲的機會將會大增，因此若能透過波蘭 PCA 讓台灣的實驗室變成 NB，將對台灣產業有實質幫助。

於會議中的簡報，PCA 舉了個例子來說明相關的過程與單位。如圖 35 所示，若是一個產品(如：智慧型手機)要通過 EMC 測試，就需要經過 Notified Body 的測試驗證才行。



圖 35 產品進入歐盟之案例概述

而針對 PCA 對於認可 NB 的要求，TAF 許執行長提問：在波蘭當地的 NB 有沒有員工人數的限制？PCA 的回覆是沒有人數的限制，只要是當地的公司即可。此外也提問是否可由 TAF 代替 PCA 進行評鑑？PCA 回覆以目前的方式，仍然要是 PCA 對欲申請成為 NB 的單位進行認證才行。

本次會議取得相當多的資訊，對於後續台灣本土實驗室是否透過 PCA 取得 NB 資格，將有評斷的依據。圖 36 與圖 37 分別是 PCA 對標準檢驗局團員們簡介其中心背景，以及會面討論的情形。圖 37 由左到右分別是本局劉明忠局長、財團法人全國認證基金會許景行執行長、駐波蘭代表處經濟組陳文誠組長、PCA 副主任 Mr. Andrzej Kolasa、主任 Ms. Lucyna Olborska。



圖 36 PCA 進行簡報



圖 37 本局劉明忠局長(左一)與 PCA 主任 Ms. Lucyna Olborska(右一)討論中
(左起依序為本局劉明忠局長、財團法人全國認證基金會許景行執行長、駐波蘭代表處經濟組陳文誠組長、PCA 副主任 Mr. Andrzej Kolasa、主任 Ms. Lucyna Olborska)

表 19 拜訪 PCA 與會人員名單

姓名	單位	職稱
Lucyna Olborska	PCA	主任
Hanna Tugi	PCA 食品測試驗證部	副主任
Andrzej Kober	PCA 機械測試驗證部	副主任
Matgorzata Tworek	PCA 內部稽核部	經理
Tadeusz Matras	PCA	經理
陳文誠	中華民國駐波蘭代表處經濟組	組長
陳宗裕	中華民國駐波蘭代表處經濟組	一等商務秘書

八、9月13日(週三)

■ 拜會波蘭電力交易中心(Towarowa Gielda Energii SA, TGE)

波蘭電力交易中心(TGE)成立於1999年，從其一開始成立，就為了電力交易領域的創新解決方案而努力，在其成立的六個月內，其電力現貨市場(electrical power spot market)的方案即就位且開始運行，市場上的價格成為了雙方契約的基準。

因為TGE為第一個也是迄今為止的電力交易所，所以在2003年獲得了證券股票交易委員會(現在在金融監督管理委員會Komisja Nadzoru Finansowego, KNF底下運作)商品市場運作許可。也由於TGE建置了最新技術的解決方案，且相對應的IT基礎建設也到位，所以在2005年其被指派建立並管理再生能源電源證書註冊(register of certificate of origin)註冊的事務，2007年其受理電源證書的範圍擴大至汽電共生。

2006年TGE與國家排放許可證交易系統合作推出了二氧化碳排放證明現貨市場。這個市場的參與者可以交易EUA單位(歐盟津貼)。

2008年推出了電力衍生產品市場。2009年推出了IRDN24指數的期貨合約報價的金融衍生品市場。2012年12月31日啟動天然氣現貨市場。TGE提供電力交易平台，工作重點是提高管理市場的流動性，並向交易所的成員和參與者提供現代能源交易工具。

會議中TGE介紹了其憑證的流程。如圖38所示，首先是由發電業者向波蘭能源管理署(Energy Regulatory Office, ERO)申請憑證，並由電網營運商確認。接著ERO將提交相關發證資料及證書給TGE註冊，由TGE接管後續證書處理事宜等事宜，而這些證書將出售給售電公司及其他有再生能源發電義務之機構。最後有再生能源發電義務之機構須向TGE將證書核實為再生能源使用證明，註銷(繳回)其證書以示義務已執行，並以此避免額外規費之索求。



圖 38 電源證書的流程



圖 39 波蘭歷年再生能源裝置量

雖然波蘭的電源證書(憑證)的制度也有遇到些困難及挑戰，像是相關單位沒有明定支持再生能源政策的終點；國家的目標沒有跟上再生能源的發展，所以沒有同步的政策以處理供應過剩的情況...等。但如圖 39 所示，波蘭再生能源的發展卻也因為有政策的支持，從 2015 年裝置容量小於 1158 MW，增加到 2016 年的 8478 MW，此方面可作為國內發展再生能源之參考。

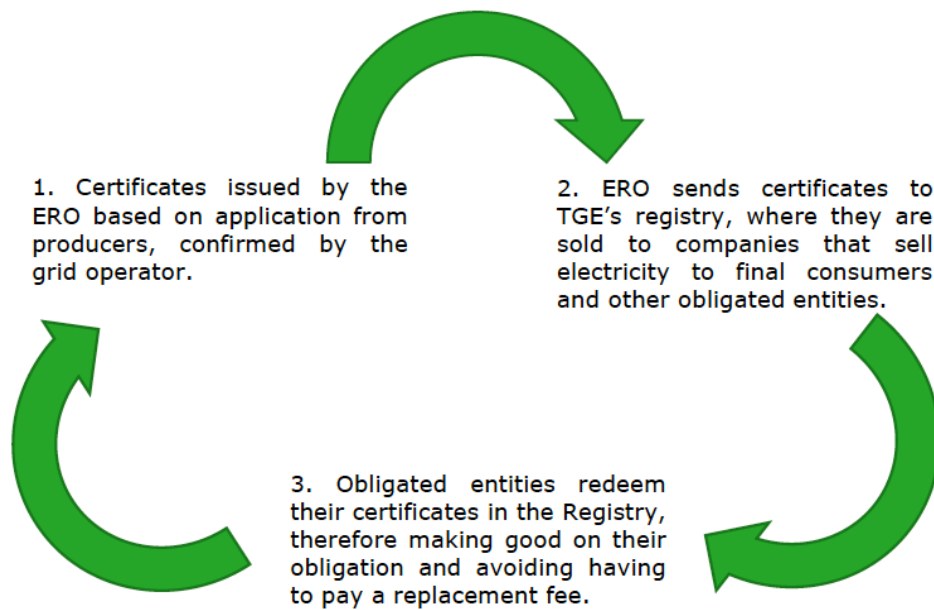

圖 40 國內專業法人簡報

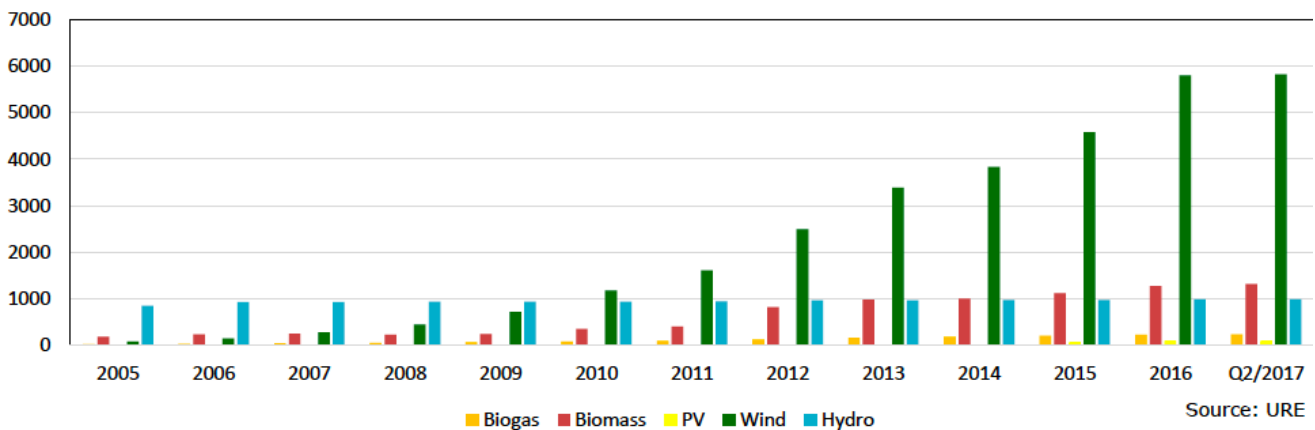

圖 41 本局劉明忠局長(左)致謝 TGE 董事會主席 Pawel Ostrowski(右)

值得一提的是，TGE 於交易平台的發展令人驚艷。如圖 42 全體人員合影照片所示，其報價室後方的即時報價系統頗具規模，在了解其發展背景後，這對於本局剛起步的再生能源憑證，是值得借鏡參考的地方。



圖 42 參訪團隊與 TGE 人員合影

(由左起依序為財團法人台灣電子檢驗中心林昀緯組長、經濟部標準檢驗局憑證中心推動辦公室吳佳璇專員、財團法人全國認證基金會陳元貞處長、財團法人全國認證基金會許景行執行長、本局謝翰璋主任秘書、財團法人台灣電子檢驗中心李海清執行長、TGE 顧問 Jacek Ostas、本局劉明忠局長、TGE 董事會主席 Pawel Ostrowski、台灣大電力研究試驗中心張忠良董事長、TGE 市場整合部總監 Maciej Olejniczak、駐波蘭代表處經濟組陳文誠組長、經濟部標準檢驗局憑證中心推動辦公室郭沐鑫專員、財團法人台灣電子檢驗中心呂玉珍課長、財團法人台灣大電力研究試驗中心張庭綱專案經理)

表 20 TGE 與會人員名單

姓名	單位	職稱
Pawel Ostrowski	TGE	董事會主席
Maciej Olejniczak	TGE 市場整合部	總監
Jacek Ostas	TGE	顧問
Monika Krol	TGE 管理處	處長
Ewa Silora	TGE	經理
陳文誠	中華民國駐波蘭代表處經濟組	組長
陳宗裕	中華民國駐波蘭代表處經濟組	一等商務秘書

■ 拜會駐波蘭代表處

駐波蘭代表處陳銘政代表撥冗接見本局所有團員，陳代表表示過去派駐泰國期間，大力推動台灣與泰國貿易，實質強化了台泰貿易往來，現在來到波蘭，也積極拓展台灣與波蘭之交流與貿易相關活動，故關心本局此次到訪波蘭目的及參訪狀況，希望本局的參訪交流可促進台波兩國關係。

本局劉局長先向陳代表說明此次來訪英國、德國之目的與成果，再敘明為簡化台灣商品出口歐洲時的檢驗手續，故規劃先與波蘭相關單位達到雙邊承認後，再進入歐盟體系。如本次應波蘭認證中心之邀約，就我國驗證機構成為歐盟指定機構議題與波方洽談，以協助我國商品順利輸銷歐盟；前往見證波蘭化學物質局與財團法人全國認證基金會簽屬合作備忘錄，最終目標也在於促進我國產業出口產品上市及行銷。



圖 43 參訪團隊與駐波蘭代表處人員會談

表 21 駐波蘭代表處與會人員名單

姓名	單位	職稱
陳銘政	中華民國駐波蘭代表處	代表
Colin Kao	中華民國駐波蘭代表處	政治組組長
Michael C. C. Lee	中華民國駐波蘭代表處	一等秘書
陳文誠	中華民國駐波蘭代表處經濟組	組長
陳宗裕	中華民國駐波蘭代表處經濟組	一等商務秘書

九、9月14日(週四)

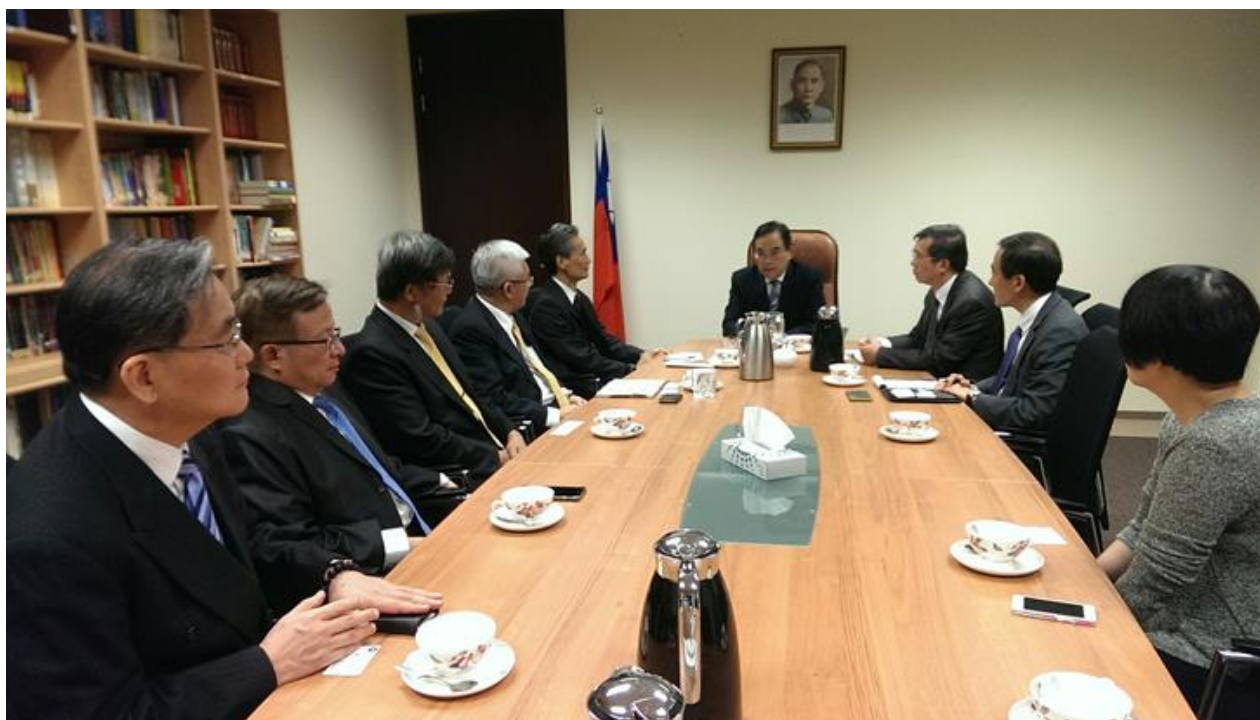
■ 拜會波蘭化學物質局(Bureau for Chemical Substances, BCS) 並見證合作備忘錄簽屬

波蘭化學物質局(Bureau for Chemical Substances, Poland)係於波蘭負責化學物質與化學品相關事務管理的權責機關，並為波蘭優良實驗室操作(Good Laboratory Practice, GLP)方案之法規權責機關及監控單位，亦為經濟合作暨發展組織(Organization for Economic Co-operation and Development, OECD)GLP制度的波蘭成員國代表機構。



圖 44 化學物質局組織架構圖

為進一步強化我國優良實驗室操作之監控系統，我國與負責波蘭化學物質與化學品相關事務管理的波蘭化學物質局，在本局劉明忠局長及駐波蘭代表處經濟組陳文誠組長見證下，由波蘭化學物質局行政局長 Anna Graczyk 與財團法人全國認證基金會(Taiwan Accreditation Foundation，以下簡稱 TAF)許景行執行長於波蘭羅茲完成雙方「優良實驗室操作資訊交換及合作備忘錄」之簽署，開啟我國在 GLP 事務上與歐洲國家合作的新局，雙方就 GLP 技術與人員展開合作與交流。



圖 45 BCS 與我參訪團隊交流情形

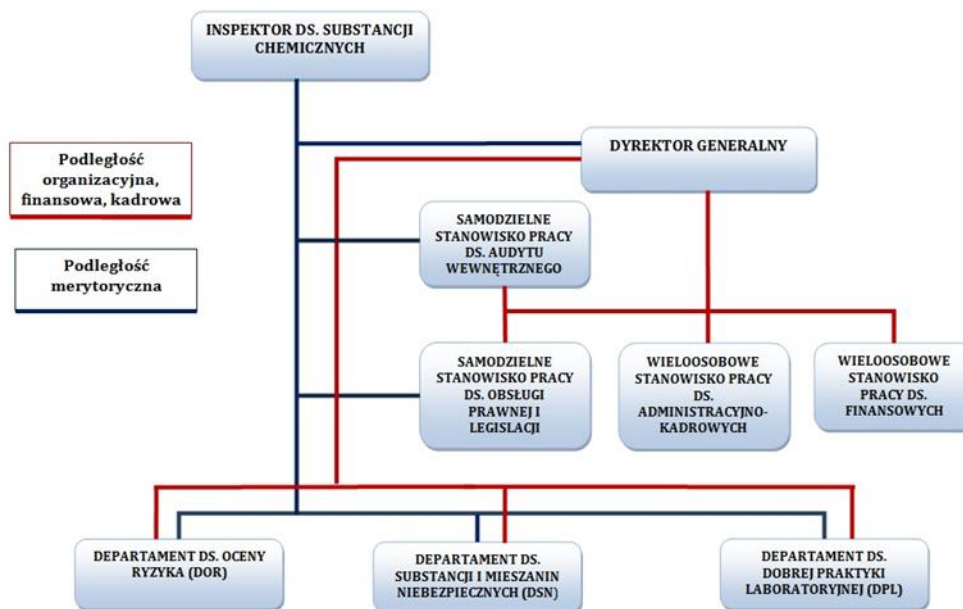

圖 46 BCS 與 TAF 簽署合作備忘錄

(由左至右依序為波蘭化學物質局局長 Agnieszka Dudra、本局劉明忠局長、財團法人全國認證基金會許景行執行長)

標準檢驗局為我國經濟合作暨發展組織(Organization for Economic Co-operation and Development, 以下簡稱 OECD)GLP 符合性監控系統(Compliance Monitoring Program, CMP)的監控機關，並委託 TAF 執行及推動 GLP 事務，多年來推動與其他國家相關機構進行合作，以使我國化學品、農藥、藥品等產品測試數據為其他國家接受，同時，我國亦已與美國環保署及紐西蘭國際認證組織簽署數據相互承認協議。

OECD GLP 係一套管理的模式與要求，對於試驗單位作業程序與研究計畫、執行、監督、記錄與報告等所需之條件予以規範，也是目前國際上各國化學品主管機關接受報告的重要憑藉，試驗機構若符合 OECD GLP 要求，試驗報告就容易為權責機關接受。國內目前為 TAF OECD GLP 登記的試驗機構有 23 家，代表這些機構係依據 OECD GLP 要求進行測試，並可確保其化學品與化學產品安全性試驗數據之品質與有效性。透過此次 GLP 合作之建立，不僅將促進臺波兩國間的友誼，對雙方在化學物質與化學品的監控技術上亦將有更進一步的提升，進而對未來我國相關產品的出口有所助益。(詳細資料參見附件)

表 22 波蘭化學物質局與會人員名單

姓名	單位	職稱
Agnieszka Dudra	波蘭化學物質局	局長
Anna Graczyk	波蘭化學物質局	行政局長
Marek Ubraniak	波蘭化學物質局 GLP 查核員部	處長
Mariusz Godala	波蘭化學物質局 GLP 查核員部	查核員
陳文誠	中華民國駐波蘭代表處經濟組	組長
陳宗裕	中華民國駐波蘭代表處經濟組	一等商務秘書

十、9月15日（週五）

■ 拜會波蘭證券交易所

駐波蘭經濟組陳秘書宗裕於本團拜會波蘭電力交易中心後，臨時接獲波蘭證券交易所理事會秘書來電表示該單位主席 Dr. Marek Dietl（波蘭總統的經濟顧問）及副主席 Mr. Michal Cieciorski 二位希望能與本局劉局長見面，雙方就「綠電憑證」議題加以討論，副主席 Cieciorski 先生表示波蘭「綠電憑證」已上市交易，提供自由買賣，因此提升「綠電憑證」之相關附加價值，進而亦提升憑證之整體功效，雙方亦就未來合作交換意見，彼此交談甚歡，副主席 Cieciorski 先生亦表示願意就「綠電憑證」上市將面臨之困難問題，提供相關技術支援，劉局長當面邀請主席 Dr. Dietl 及副主席 Cieciorski 先生來臺訪問，二位均當場允諾將會優先考慮，後續將請駐波蘭經濟組陳組長文誠與陳秘書宗裕持續追蹤。



圖 47 本局劉明忠局長(中)與波蘭證券交易所理事會主席 Dr. Marek Dietl (左)及副主席 Mr. Michal Cieciorski (右)於會談後合影留念

表 23 波蘭證券交易所理事會與會人員名單

姓名	單位	職稱
Marek Dietl	波蘭證券交易所理事會	主席
Michal Cieciorski	波蘭證券交易所理事會	副主席
陳文誠	中華民國駐波蘭代表處經濟組	組長
陳宗裕	中華民國駐波蘭代表處經濟組	一等商務秘書

伍、備忘錄內容

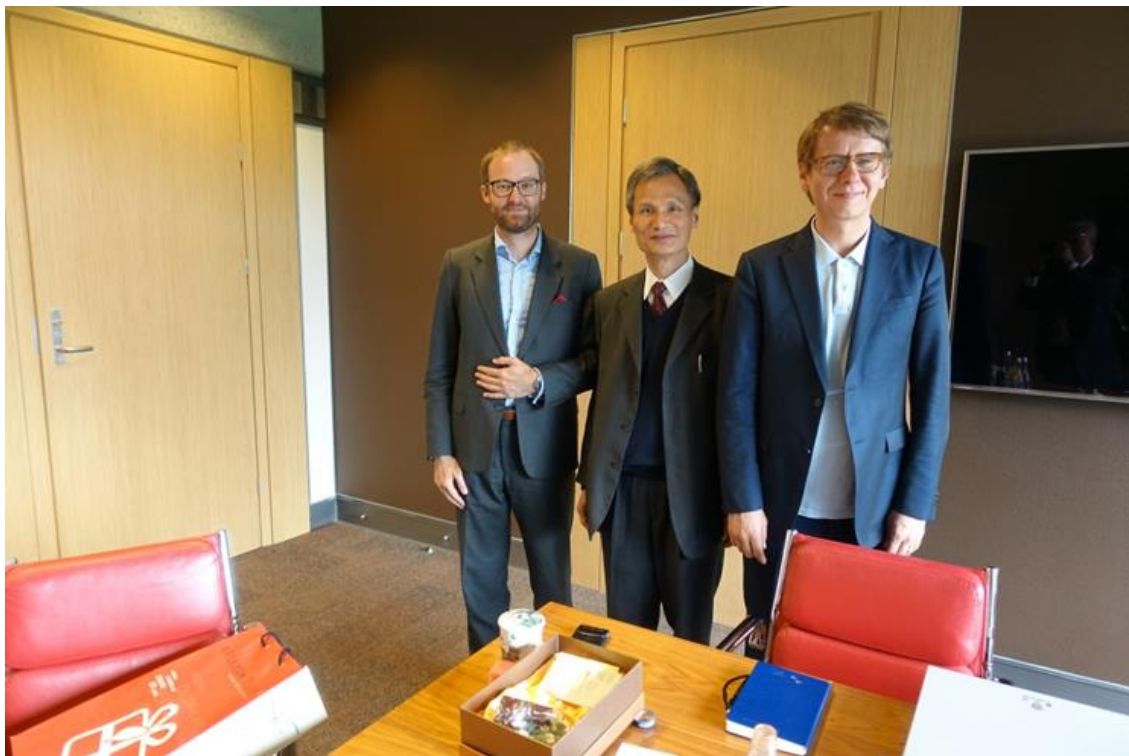
一、Global Maritime

目的：於離岸風場專案上建立 Global Maritime 與財團法人中國驗船中心、財團法人金屬工業研究中心、財團法人台灣電子檢驗中心、財團法人台灣大電力研究試驗中心和財團法人台灣經濟研究院之合作關係，以達到增加離岸風場建造之專業知識，以及確保離岸風場建造之品質、安全性及可靠性。

合作內容：於離岸風場領域展開合作，包括離岸風場之相關研究、海事保證鑑定、第三方查驗及技術研討會。

二、Green Giraffe

目的：建立 Green Giraffe 與財團法人台灣經濟研究院的合作關係，並於離岸風電金融業務就非機密資訊進行討論與交流。

合作內容：於再生能源財務盡職調查進行合作，協助國內業者建立再生能源案場之財務模型、融資架構以及風險評估能力。

三、LOC

目的：於離岸風場專案上建立 LOC 與財團法人中國驗船中心、財團法人金屬工業研究中心、財團法人台灣電子檢驗中心、財團法人台灣大電力研究試驗中心和財團法人台灣經濟研究院之合作關係，以達到增加離岸風場建造之專業知識，以及確保離岸風場建造之品質、安全性及可靠性。

合作內容：於離岸風場領域展開合作，包括離岸風場之相關研究、海事保證鑑定、第三方查驗及技術研討會。

四、K2

目的：於離岸風電專案上建立 K2 與財團法人中國驗船中心、財團法人金屬工業研究中心、財團法人台灣電子檢驗中心、財團法人台灣大電力研究試驗中心和財團法人台灣經濟研究院之合作關係，以達到共同執行風力發電廠技術盡職調查，並透

過共同執行經驗，累積台灣技術能力。

合作內容：於離岸風電技術盡職調查領域展開合作，包括座談會及技術研討會。

五、DEWI-OCC

目的：於離岸風電專案上建立 DEWI-OCC 與財團法人中國驗船中心、財團法人金屬工業研究中心、財團法人台灣電子檢驗中心、財團法人台灣大電力研究試驗中心和財團法人台灣經濟研究院之合作關係，以達到共同執行風力發電廠技術盡職調查，並透過共同執行經驗，累積台灣技術能力。

合作內容：於離岸風電技術盡職調查領域展開合作，包括座談會及技術研討會。

六、TÜ V SÜ D

目的：於風能產業上建立 TÜ V SÜ D 與財團法人中國驗船中心、財團法人金屬工業研究中心、財團法人台灣電子檢驗中心、財團法人台灣大電力研究試驗中心和財團法人台灣經濟研究院之間的合作關係雙方合作關係，以達到增加風能產業之專業知識，以及確保風能產業之品質、安全性及可靠性。

合作內容：於風能產業領域展開合作，包括風能產業之相關研究、查驗、檢驗服務及技術研討會。

七、DNVGL

目的：建立 DNV GL 與財團法人中國驗船中心、財團法人金屬工業研究中心、財團法人台灣電子檢驗中心、財團法人台灣大電力研究試驗中心和財團法人台灣經濟研究院之間的合作關係，就非機密技術信息進行討論和交流，海上風力測試認證相關技術和服務。

合作內容：以離岸風力測試和認證相關技術、服務與資訊為主，並可透過會議、研討會與簡報介紹交流經驗與資訊。

陸、心得

1. 再生能源憑證自今年5月發行後，累計至11月30日止已發行12,146張，為了推動再生能源憑證制度，訪問國際組織碳信託(Carbon Trust)及碳揭露(CDP)二機構，讓吾人瞭解及學習這些機構在相關領域豐富的經驗及卓越的知識，未來可供台灣發展供應鏈碳足跡認證標準，以提升我國再生能源憑證之價值性。
2. CDP在碳揭露及溫室氣體盤查之相關環境效益領域中有舉足輕重的地位，該機構不僅透過各大企業所填寫的問卷，建立了具公信力的企業溫室氣體排放量資訊平台，目前我國名列CDP5的調查名單有ASUS、ACER、HTC等大廠，國內企業對CDP的重視程度可見一斑，如能將T-REC與CDP鏈結，將可鼓勵台灣供應鏈廠商使用T-REC以作為使用綠電證明。
3. 為確保離岸風場設置之安全性，並提供可信賴之技術評估，供金融及保險業者作為專案融資貸款及保險之風險管理依據，協助離岸風場相關產業發展，國際上係以第三方檢測驗證單位進行『專案驗證、盡職調查及海事保證鑑定』三大驗證。
4. 鑑於TÜV SÜD、DEWI-OCC及DNV-GL三團隊已被德國聯邦海事局(BSH)認可為離岸風電場『專案驗證』的驗證機構，藉由與TÜV SÜD、DEWI-OCC及DNV-GL三團隊的合作，可以快速提供國內單位驗證風場場址及設計條件評估，確認離岸風力機及風場可符合於台灣環境。
5. 鑑於台灣離岸風力電場的大規模開發，廠商對於風場建置之投融資需求也日益上升，在國內缺乏相關專案融資經驗下，建立離岸風場專案融資盡職調查能力為當務之急，因此本局相關財團法人與Green Giraffe、DEWI-OCC及DNV-GL三團隊的合作，可共同建立台灣再生能源盡職調查之能力，可滿足台灣再生能源開發時之專案融資需求。

6. 因海事保證鑑定(Marine Warranty Survey)為保險公司在承保工程建造保險(Construction All Risk, CAR)時的必要條件，為有效控管離岸海事工程的高風險，本局相關財團法人單位就『海事保證鑑定』與 Global Maritime、LOC 及 DNV-GL 三家國際知名海事工程的專家團隊合作，可確保所有海事工程都是依據業界慣例或標準程序進行，使施工風險可有效控制，進而降低保險公司承保費用，創造施工廠商、保險公司雙贏局面。

7. 德國聯邦海事局 (Bundesamt für Seeschifffahrt und Hydrographie, BSH) 是德國經濟海域 (Economic Exclusive Zone, EEZ) 的守門人，負責所有德國海域的使用及維護。德國交通運輸部(Ministry of Transport)也根據「聯邦海事法(Federal Maritime Responsibilities Act)」及「施行細則(Ordinance on Installations Handling Materials Hazardous to Water)」，將風能主管機關指定為德國海事局(BSH)，執行德國專屬經濟區 (EEZ) 風電場的申請程序。德國政府計畫 2030 年要有建置 3000 座離岸風機， BSH 花費相當多心力，在避免離岸風電對海洋可能產生的不良影響，包括施工噪音、航海自由等。並且與專家合作，制定並發布相關技術指南(Guideline)，以及海上風力機建設時的相關要求，確保所有設備和結構部件都得到認證，來提高法律和投資安全，BSH 的做法，可以減低離岸風場建造發展時，所產生的風險及衝擊，相當值得吾人學習。

8. 波蘭電力交易中心 TGE 早在 1999 年即開始發展電力憑證交易市場，而隨著其 IT 系統的到位，電子交易平台、再生能源憑證的發展也就順勢發展。這對於 IT 產業發展先進的台灣來說，值得吾人借鏡。

柒、致謝

1. 本次訪問英國、德國、波蘭，經過事前週密的聯繫，行程緊湊，銜接良好，順利完成與 Global Maritime、Green Giraffe、LOC、K2、DEWI-OCC、TÜ V SÜ D、DNV GL 簽署合作備忘錄。由衷感謝駐英國台北代表處林永樂代表及經濟組李組長與相關同仁、駐德國台北代表處漢堡辦事處沈文強處長及經濟組何組長與相關同仁的協助。
2. 同時感謝駐波蘭代表處陳銘政代表及經濟組陳組長與相關同仁的協助，使得本局與大電力中心、全國認證基金會可以順利拜訪波蘭電力交易中心及認證中心，波蘭化學物質局，見證全國認證基金會與波蘭化學物質局的優良實驗室操作 (GLP) 合作備忘錄的簽署。
3. 此外，在行程接近尾聲時，臨時接獲波蘭證券交易所主席暨波蘭總統經濟顧問 Dr. Marek Dietl 及副主席 Mr. Michal Cieciorski 邀約，感謝在駐波蘭經濟組陳文誠組長與陳宗裕秘書充分準備資料及隨同拜訪下，非常愉快的與波蘭證券交易所就綠電憑證之相關議題進行討論，成果豐碩，值得肯定。

捌、附件



RENEWABLES EXPERIENCE SUMMARY

Global Maritime Consultancy & Engineering

To find out more, please contact:

CE-Singapore-Marketing@globalmaritime.com

www.globalmaritime.com

8 Shenton Way #32-01 AXA Tower
Singapore 068811
+65 6238 1811

**GLOBAL
MARITIME**



Summary

The following capability statement presents an overview of some of the core competencies which Global Maritime (GM) have to offer our clients. With over 35 years working in the marine and offshore industries, we have undertaken a wide range of engineering projects to meet the requirements of the oil and gas industries, and in the later years, to also meet the requirements of the renewable industry.

Our capability to undertake a range of complex turnkey projects from large to small will be shown in this capability statement. In addition to discrete projects, GM have also undertaken full vessel designs to both class and detailed design level.

With a number of offices located both in the U.K. and elsewhere around the world, GM have an array of skills to meet the needs of both the Oil & Gas and Renewables industries. Some of the key engineers are mentioned at the end of the capability report together with the suite of software tools available within the various offices.

If more information is required on any of the projects listed, please do not hesitate to contact us for details.

These materials are the Work Product of Global Maritime, and no reliance on this work product is authorised by Global Maritime, and Global Maritime accepts no liability for any reliance by any person on the work product contained herein.

© This document is the property of Global Maritime Consultancy Pte. Ltd. and is not to be copied, nor shown, to third parties without prior consent.

Global Maritime Consultancy Pte. Ltd.

8 Shenton Way
#32-01, AXA Tower
Singapore 068811

T +65 6238 1811
F +65 6238 1322

Table of Contents

1. INTRODUCTION.....	4
2. ABOUT GLOBAL MARITIME	5
2.1 WHAT WE DO.....	5
2.2 OFFICES	6
3. OFFSHORE RENEWABLE PROJECTS...7	
3.1 OFFSHORE RENEWABLE CONSULTANCY.....	7
3.2 MARINE WARRANTY SURVEY.....	12
3.3 GM SOFTWARE.....	13

1. INTRODUCTION

Global Maritime is a world leading marine, offshore and engineering consultancy with 35 years of industry experience. We provide a range of services covering areas such as design, engineering and consultancy; marine warranty; marine operations; dynamic positioning; risk and safety. We have a reputation for meeting the highest standards expected of our clients, whilst employing professional staff from a wide range of backgrounds including civil and structural engineers; naval architects; mechanical and marine engineers and master mariners.

Our vision is to be the global leader in advancing safety within the offshore and marine environment through the application of our design and engineering expertise; world leading assurance programme; working standards and innovative practical solutions.

Global Maritime have also developed a wide range of in house specialist software for carrying out various types of analyses and simulations, including mooring studies; stability and weight management; hydrostatics and simulation of vessel operations and schedules. We also utilise a number of additional industry standard software packages in order to ensure we have the tools to enable us to tackle the most complex analysis and design studies.

This document will outline all the services available to cover the range of activities in the offshore oil, gas and renewable industries.

2. ABOUT GLOBAL MARITIME

2.1 What We Do

Global Maritime is an independent marine, offshore and engineering consultancy offering specialist maritime expertise to oil and gas, legal, shipping, insurance and port and harbour clients world-wide.

Our Professional staff consist of:

- Civil and Structural Engineers
- Naval Architects
- Mechanical and Marine Engineers
- Master Mariners
- Electrical Engineers
- DP Specialists
- Marine Warranty Surveyors

Global Maritime offers design analyses and verification of offshore structures, with services ranging from concept development, through basic design and classification society approval to detailed design and shipyard support during construction and commissioning.

We have undertaken design and modification of both monohull and semi-submersible vessels and rigs utilising structural and hydrodynamic expertise and software to ensure optimisation to client requirements.

Global Maritime specialise in intact and damage stability analyses, motion analyses and the design of inshore and offshore moorings. We also provide structural strength analyses of vessels, jackets and modules for transportation, lifting and installation operations, as well as fatigue studies.

Additional services include:

- Marine Engineering and Consultancy
- Marine Warranty
- Marine Operations
- Dynamic Positioning
- Risk & Safety
- Port, Harbour and Shipping
- Engineering specialist software
- 3D visualisation
- Crane department

2.2 Offices

Global Maritime was established in 1979, and has a global reach with 5 regional offices worldwide including Europe, Americas, Asia and Africa. There are 4 offices in the Asia Pacific which includes the following

- Singapore (Regional Office)
- Kuala Lumpur, Malaysia
- Tangerang, Indonesia
- Shanghai, China

3. OFFSHORE RENEWABLE PROJECTS

Over the past number of years, GM have been increasingly involved with the offshore renewable industry. The involvement ranges from specific vessel design through to research for the installation of new offshore turbine types, installation of offshore wave power devices and operational support to offshore wind farm development.

Detailed below are some of the projects which GM have had direct involvement.

3.1 OFFSHORE RENEWABLE CONSULTANCY

3.1.1 Ocean Power Technologies | PB150 Power Buoy Installation

Global Maritime provided the following services in the successful trial of the PB150 wave power device in the Moray Firth, Offshore Scotland.

- Design and analysis of 3-leg spread mooring system
- Pre-lay of anchors and mooring system at test site
- Procurement of all tow and installation equipment; charter of all installation vessels.
- Tow of the PowerBuoy from Invergordon to test site.
- Upending and connection to the pre-laid moorings.
- Removal of PowerBuoy and all equipment at end of six month trial period

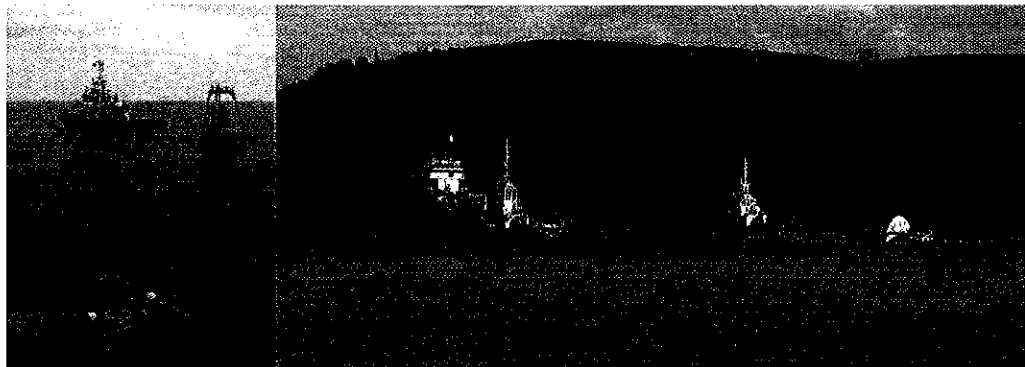

3.1.2 Ocean Power Technologies | PB40 Power Buoy Mooring

Global Maritime designed and analysed a 3-leg spread mooring system for the deployment of the PB40 device at the BIMEP location. The analysis included ultimate strength and fatigue analyses.

For commercial reasons, the deployment site was changed to New Jersey, US, for which Global Maritime re-verified the mooring system design.

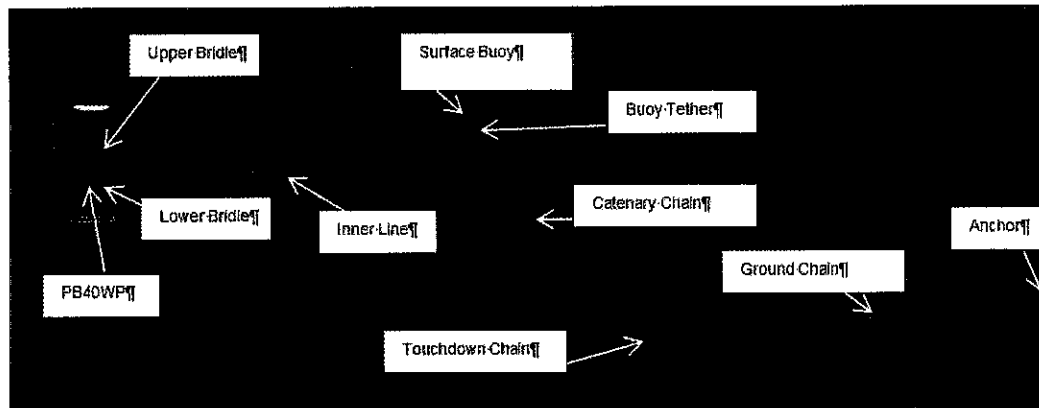

3.1.3 SSE | Beatrice Wind Farm

Beatrice Wind Farm is being constructed in the outer Moray Firth on the North-Western point of the Smith Bank. Global Maritime has an ongoing project with SSE to provide Marine Assurance Services and to act as Technical Authority for the Beatrice Wind Farm.

This work is ongoing, and we are working hard with the project team to fulfil the vessel selection aspect of the work.

During the course of the project Global Maritime will verify all the marine asset selection and installation methods for the wind farm construction including:

- Load-out, transportation and installation of piles, jackets, WTG substructure and WTG;
- Load-out, transportation and installation of OSP piles, jacket and topsides;
- Load out, transportation and installation of array cable including cable protection and pull-in;
- Load out, transportation and installation of export cable Installation including cable protection and pull-in at OSP and HDD at landfall.

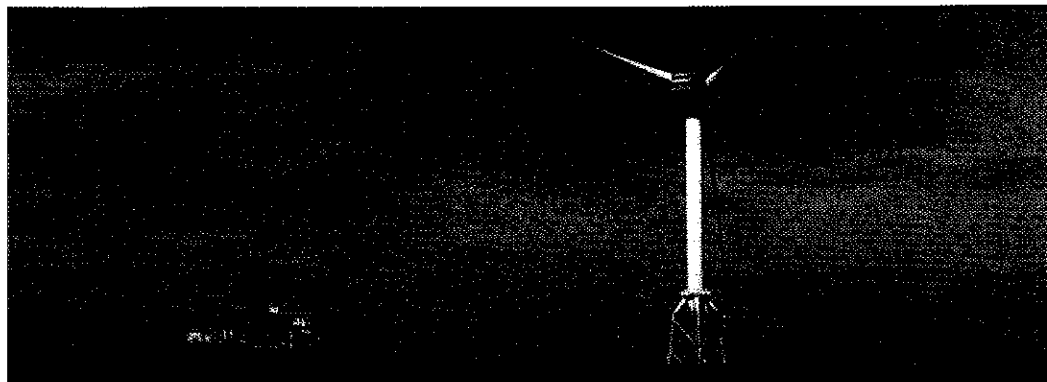

3.1.4 A2Sea | **Seafastening for BurboBank WTG Installation**

Global Maritime have designed the seafastening and grillage arrangements for the transportation of the first ever Mitsubishi Vestas 8.0MW offshore wind turbines to be installed in an offshore wind farm. This project included design, verification and creation of the detailed design drawings for the transportation and installation of the WTG components.

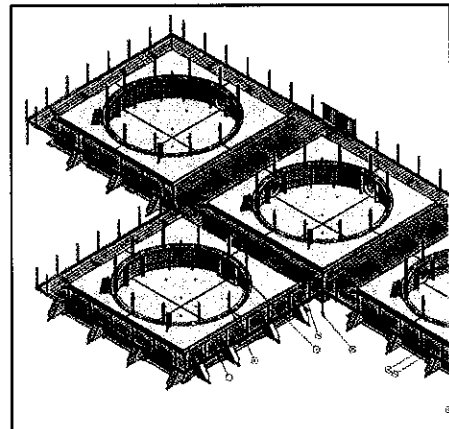
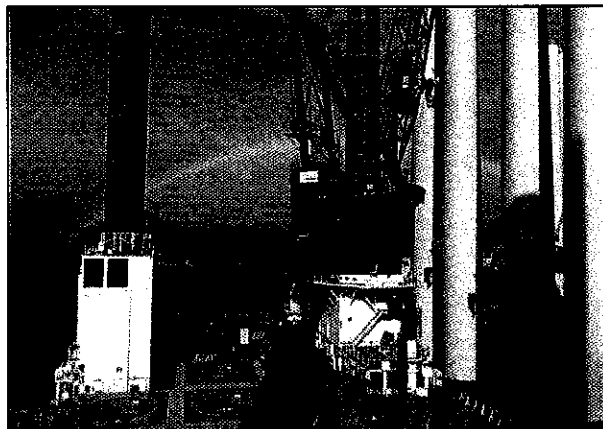

3.1.5 RWE | **Gwynt y Mor Wind Farm**

Assessment of loadout, transportation and installation methods of concrete caisson substructure for wind farm, review of candidate ports as construction base installation and uptime analysis.

3.1.6 **Lyell Power Buoy Installation**

- Tow and installation of concrete gravity base
- Tow and installation of power buoy
- Provision of 500t net weight 'sinker' for use during upending of power buoy

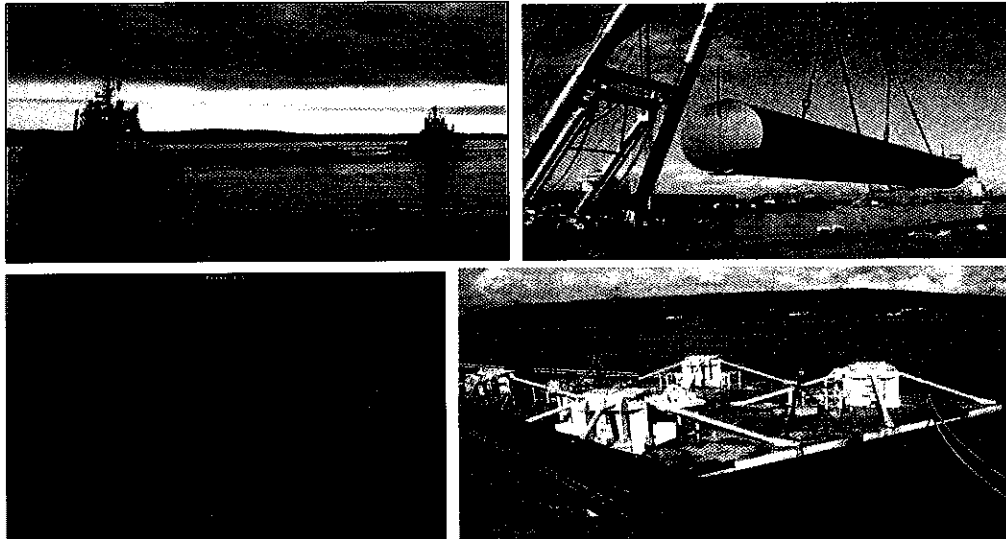

3.1.7 AWS Ocean Energy Limited | **Archimedes Wave Swing**

Marine requirements for the Archimedes Wave Swing MK III.

3.1.8 Peel Holdings | **Mersey Tidal Power**

Marine impact assessment of several different types of tidal power generation option, including a barrage, at locations in the Mersey.

3.1.9 Severn Tidal Power Group | **Severn Tidal Power Barrage**

Development of marine operations and analysis of caisson stability and mooring systems for the installation of very large concrete caissons across the Severn Estuary. Marine impact on commercial shipping.

3.1.10 Mersey Tidal Power | **Mersey Tidal Barrage**

Navigational risk, asset and personnel risk as well as marine impact assessment for the construction and operational phases of the Mersey tidal barrage. Development of marine operations for construction operations, traffic queue simulation to test commercial delays to vessels.

3.1.11 AMEC | **Current Turbine Installation**

Marine operations review and analysis of mooring systems to hold location of a large tidal current turbine design during the installation phase of lowering and securing to the seabed. System was intended for use in coastal Korea in a high current, rock seabed location.

3.1.12 **Tidal Current Turbine Installation**

Analysis of jack up and moored floating options for installation of a current turbine for Strangford Loch.

3.2 Marine Warranty Survey

In addition to the above consultancy projects, Global Maritime have extensive experience as Marine Warranty Surveyors for the installation of offshore renewable projects. A summary of the recent MWS project in this area is given in the following table.

Site	Services	Year	Main Points
DONG ENERGY Gode Wind 1 & 2 OWF	MWS	2014-2016	MWS scope for foundations, OSS and WTGs.
DONG ENERGY Gode Wind 1 OWF	MWS	2015	MWS scope for the installation of the Export cables completed.
DONG ENERGY Westermost Rough OWF	MWS	2013/2014	Full MWS scope including Export Cable installation completed.
STATOIL Dudgeon OWF	MWS	2015-2017	Full MWS scope including Export Cable installation in progress.
VATTENFALL Ormonde OWF	MWS	2011/2012	Full MWS scope including Export Cable installation completed.
E-ON Ranpion OWF	MWS	2016/2017	MWS scope for the installation of Export & Array Cables in progress.
NSW Borkum Riffgrund 1	MWS	2015-2017	MWS scope for the installation of the export cable, incl. repair, in progress.
Siem Offshore Contractors Nordsee One	MWS	2015-2016	MWS for the installation of the Nordsee One export cable in progress.
50Hertz Cluster "Westlich Adlergrund"	MWS	2015-2018	MWS scope for the installation of the export cables for the grid connection cluster "Westlich Adlergrund" ("Arkona-Becken Südost" and "Wikinger"), in progress.
SSE Beatrice OWF	Marine Assurance & Technical Authority	2015-2019	Providing technical advice on many aspects of Wind Farm Engineering and Installation, mainly within the marine team.
GREATER GABBARD OFFSHORE WIND Ltd Greater Gabbard OWF	MWS	2004	Providing marine warranty and general consultancy to Greater Gabbard Offshore Winds Limited.

3.3 GM Software

GM have many years in the development of in-house software, which is also commercially available and used by many design consultancies around the world. Listed below are some of the GM suite of software together with their uses.

GMOOR – A mooring analysis program used mainly for the analysis of spread mooring patterns for MODU's and other subsea support vessels in open water. However, it has also been used for analysis of turret moorings and quayside moorings.

It has the capability to calculate quasi-static wave frequency and low frequency motions in the frequency domain, with a time domain option also available for low frequency motions. There is also an option to include calculation of line dynamics. The program checks the results against a range of standard mooring codes including API and DNV.

It can be used for engineering assessment, planning and approval work in advance of a mooring deployment, as well as for predicting vessel motions and tensions in advance of approaching weather or a rig move.

GM Catenary – A single line 2D catenary analysis program for use in analysing moorings or towing lines. Proposed for use on tugs, anchor handling and all spread moored vessels for supporting mooring analyses and providing quick, efficient and detailed results of the catenary line problem when addressing issues such as payout and clearance above subsea assets.

GM OPSIM – A marine and offshore operational planning tool with the ability to model, simulate and test the stages, schedule, resources and limiting criteria of your operations against relevant metocean data. The simulation results allow evaluation of critical stages, availability and delay, resource pinch points and potential savings of time and effort.

Some examples of the use of GM OPSIM are for operations such as FPSO storage and off-take; offshore towage and transport; drilling availability and calculating weather windows.

GMLoadCalc – A stability and weight management program which allows semisubmersible rigs to keep track of all onboard loads, with the stability calculated relative to the weights and loads entered in the program.

HYDROGM – A suite of programs for the hydrostatic and stability analysis of floating structures such as semi-submersible units and construction barges. There are 7 integrated programs including HYDCODE and HYDWIND.

HYDROGM calculates hydrostatics and stability curves, whilst HYDCODE checks both intact and damaged stability against all relevant code criteria. HYDWIND

calculates wind loads and overturning arms on vessels such as semi-submersible floating units, jack up rigs and construction barges.

In addition, GM has an extensive suite of 3rd party software, with extensive experience in the following (amongst others):

- Orcaflex
- DNV SESAM
- Staad
- Nastran
- MathCAD
- AutoCAD
- Inventor
- Optimoor
- AutoSHIP
- Etc.

歡迎台灣代表團到英國南海岸

We welcome the Taiwanese Delegates to
the South Coast of England



E.ON presentations

- 1. Introduction to E.ON & Offshore Wind**
Giles Sibun – Origination & Development Manager, Offshore Wind
- 2. Introduction to the Rampion Project**
Chris Tomlinson – Development & Stakeholder Manager, Rampion Offshore Wind
- 3. Technical Development & Construction of Rampion**
Naren Mistry – Engineering Manager, Rampion Offshore Wind
- 4. Rampion Construction Video**
Foundation fabrication & installation. Export cable duct extension. First turbine installation.
- 5. Project Certification**
Dr. Burkhard Seif – Business Development Manager, Offshore Wind



About us

Introduction to E.ON & Offshore Wind

E.ON strategy

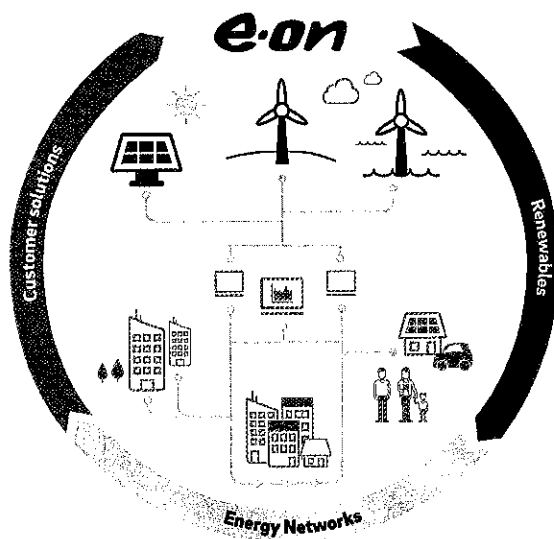

Global trends like sustainability and climate protection, digitalization and technological innovation are altering the energy landscape. At the same time our customers' energy needs are changing.

A new energy world – decentralized, green, and interconnected – is emerging. Our core businesses reflect the key energy trends:

The global growth of renewables

The transformation of yesterday's power lines into tomorrow's smart energy networks

The increasing demand for innovative customer solutions

Partner for the New Energy World

We offer attractive propositions to our customer group

Our offering



Green energy
Providing **long-term Power Purchasing Agreements (PPA)** to Utilities and B2B customers¹

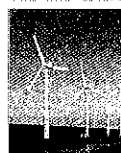

Green assets
Monetizing parts of our development pipeline and operating asset portfolio through establishing long-term partnerships

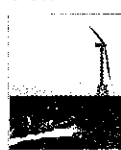

Services
Offering **full scale operations & maintenance, short term repairs, as well as technical & commercial site management services** to customers

Our customers (examples)



Utilities

Commercial & Industrial



Financial Investors



Strategic Investors

Asset managers



Wind farm Owners

1. Including selling renewable energy to customers across Europe via our local retail organizations

Renewables at a glance

What we do

- We are among the largest renewable energy players in our core markets (Europe and US)
- Our focus is offshore and onshore wind, as well as utility-scale PV and energy storage
- We deliver and own utility scale renewable projects, engaging in development, construction and operation
- We partner with investors offering stakes in our existing green assets or projects under development
- We provide long term green energy PPAs¹ to our customers as well as offering Wind O&M/ AM/ EM services² to 3rd parties
- We have developed more than 6 GW of renewable energy projects since inception in 2007
- 1,100 E.ON employees work in Renewables

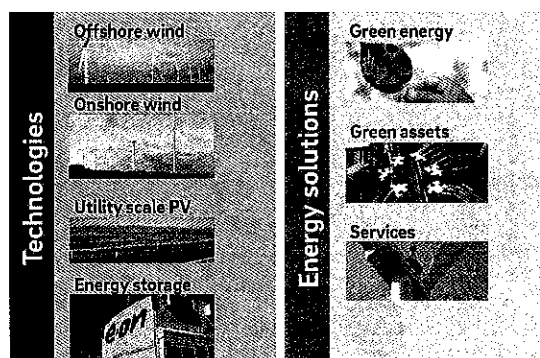

Owned capacity³ (GW)

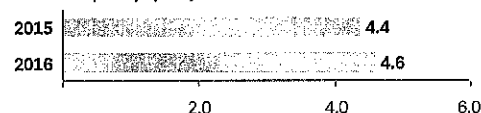

TWh produced³

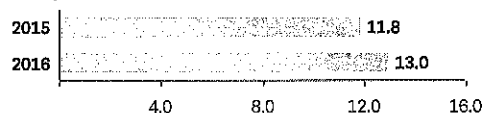

1. Power Purchase Agreements

2. O&M: Operations & Maintenance; AM: Asset Management; EM: Energy Management, via "E.ON Energy Services"

3. Pro rata

E.ON Climate & Renewables in numbers

>6 GW

delivered renewable capacity

>€10 billion

Invested in renewable energy

4.6 GW

owned renewable capacity

7

countries where E.ON Climate & Renewables operates

5.3 GW

operated renewable capacity

90%

projects built on time, on budget

Global # **3** in offshore wind¹

>10,000

blades regularly inspected each year

~1,100 employees

1. The European offshore wind industry – key trends and statistics 2016, Wind Europe

E.ON renewables portfolio

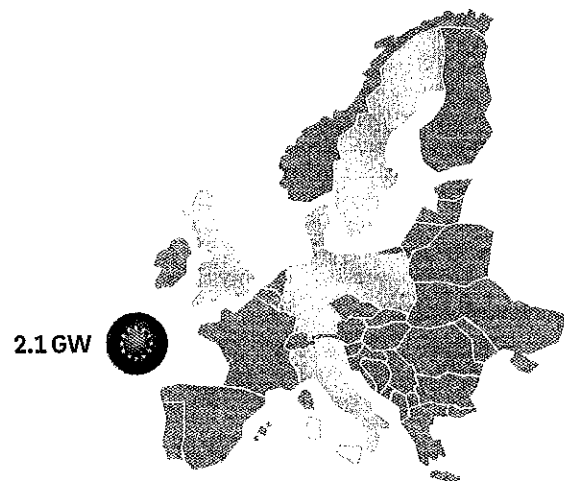
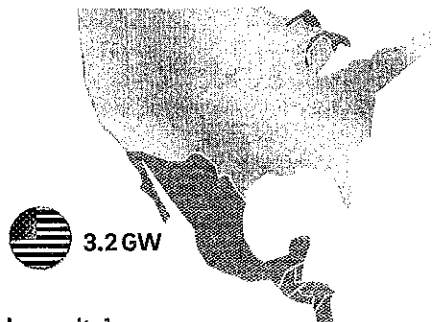

Highlights

5.3 GW Operated capacity¹

4.6 GW Owned capacity²

1.1 GW Offshore capacity

3.5 GW Onshore + PV capacity

1. Operated sites, where E.ON is the operator, regardless the ownership share
2. Prorata

E.ON ranks as global #3 in offshore wind power companies¹

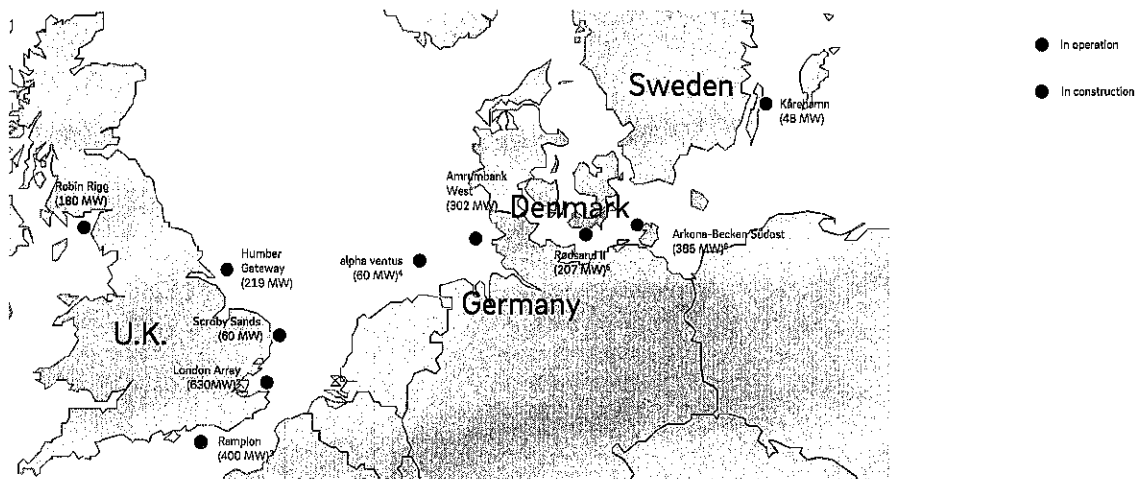

1. The European offshore wind industry – key trends and statistics 2016, Wind Europe
2. E.ON share 30% (189 MW)
3. E.ON share 50% (200 MW)
4. E.ON share 26% (16 MW)
5. E.ON share 20% (41 MW)
6. E.ON share 50% (193 MW)

We have an uncompromising focus on Health & Safety

- E.ON Renewables TRIF¹ has **declined more than 60%** over the last 7 years
- Strong leadership in HSE – shaped further by a **Tailor-made Leadership Program** and preventative safety management
- Robust **HSE management system** integrated into all aspects of the business and externally certified²
- Founding member of **G* Global Offshore Wind Health & Safety Association** and active member of H&S working groups in WindEurope³, GWO⁴, Renewables UK Wind Association, American Wind Energy Association

Profound Health, Safety and Environment culture key element of E.ON's value system

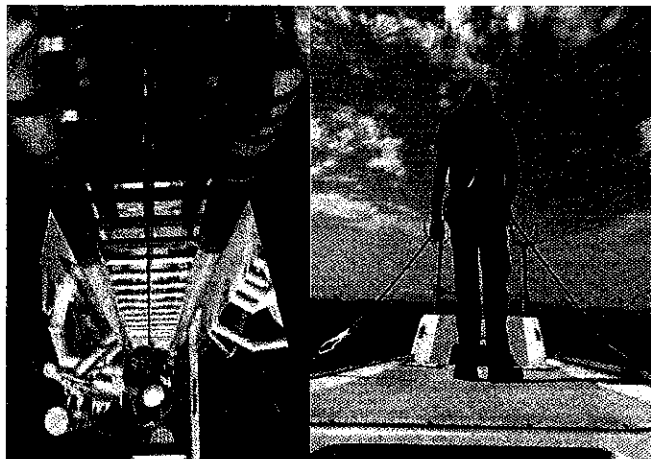

1. Total recordable incident frequency (TRIF) is the sum of recordable incidents per one million hours worked
2. According ISO 14001 and OSHAS 18001 since 2010
3. Formerly known as European Wind Energy Association
4. Global Wind Organization

Lean and diverse workforce is E.ON Climate & Renewables' most valuable asset

E.ON Climate & Renewables employees in facts and figures¹

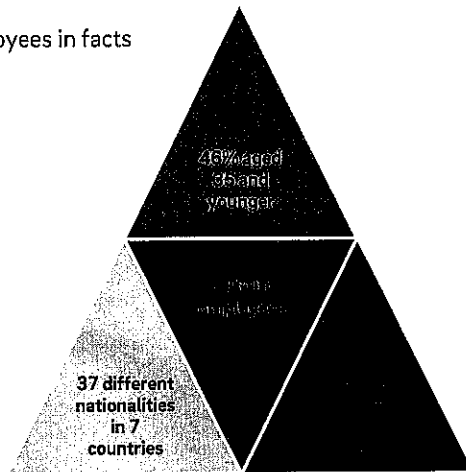

1. HR analytics as of Q1 2017

E.ON will focus on core technologies in Onshore, Offshore wind and PV and Storage

✓ Wind Onshore



✓ Solar PV



✓ Wind Offshore

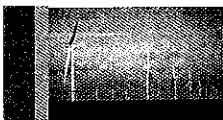

✓ Storage



- Continued focus on core technologies to maintain **leading position** in the industry
- Capitalize on **existing pipeline & capabilities** in North America and Europe to deliver projects
- Maintain **robust development pipeline** with superb project options
- Focus on **industrial scale assets** as **integrated player** to create value (development, construction, operations & maintenance)
- **Expand attractive** partnering and third party business **energy solutions** to our customers



Introduction to the Rampion Project

Chris Tomlinson

6 September 2017

e-on

Green
Investment
Bank

ENBRIDGE

Contents

1. Rampion Offshore Wind Limited
2. Location of Project Site
3. Project Considerations and Challenges
4. Onshore Design
5. Permitting & Consents
6. Project Overview
7. Timeline
8. Project Benefits

1. Rampion Offshore Wind Limited

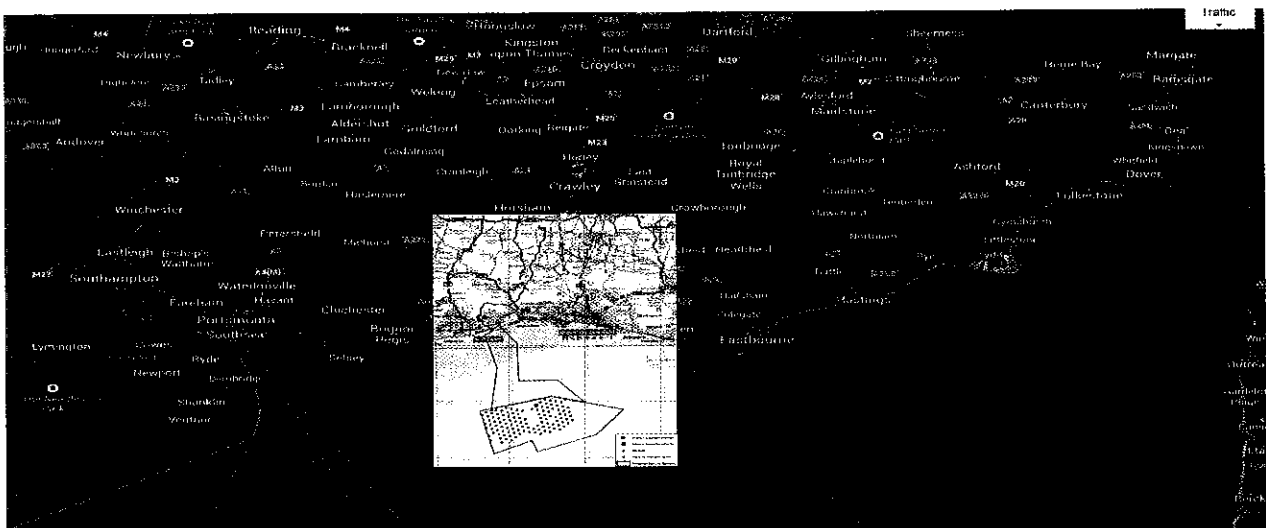
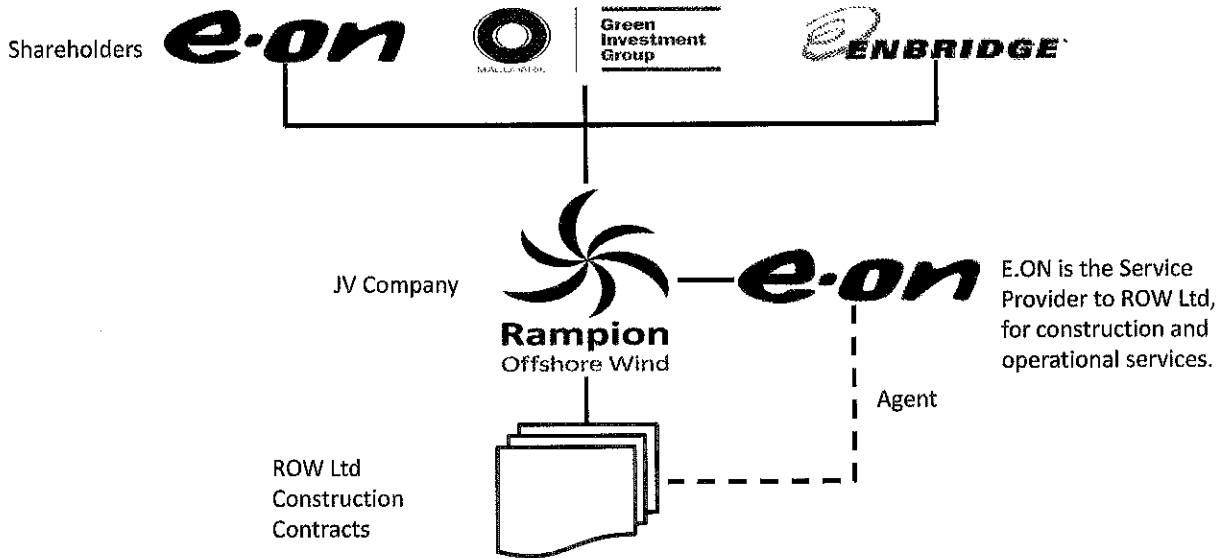

2. Location of Rampion Project - off Sussex coast, in English Channel



3. Project considerations and challenges

- Untested Planning Act 2008 - must consult meaningfully at an early stage
- Complex offshore site with varying bathymetry, challenging geology & UXOs
- Cable landfall must be close to high density residential areas
- 27km onshore cable route over National Park, main roads, railway & river
- Population approaching 1 million including a heavily populated coastline
- Nearest to shore of all Round 3 projects / 271km² site (approx 28km E-W)
- Visible on a clear day from Beachy Head to Selsey Bill (approx 90km E - W)
- Economy relies heavily on tourism, with key tourist destinations
- High level and diverse offshore commercial and recreational activity
- Several local ports and marinas nearby
- No commercial wind farms in Sussex

4. Onshore design

Landfall at Brooklands, East Worthing

27km underground cable route

Ducting methods of installation

4 x drills under beach & A259, Railway, A27 and River Adur

30m working width / 15m easement requiring haul road, topsoil and subsoil storage, and distance between circuits

New Twineham substation transforms output to connect to 400kV Bolney National Transmission Grid

Active engagement with Local Liaison Group on final layout design, seeking to reduce site area, size and scale of buildings and protect hedges and trees

Constructed under development consent requirements e.g. environmental or traffic management plans

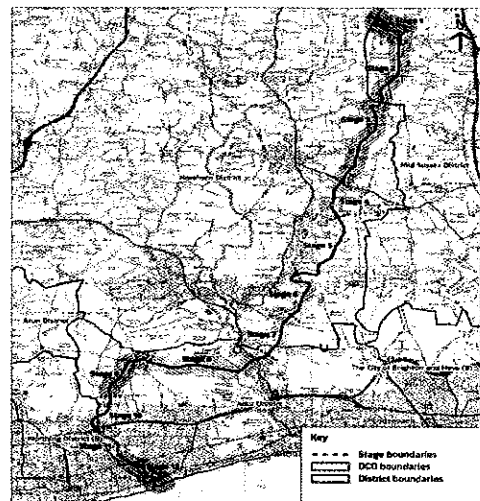

5. Permitting & Consents

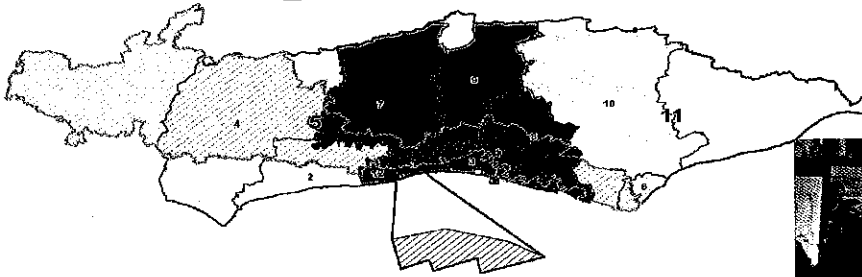

- Rampion is a Nationally Significant Infrastructure Project (NSIP)
- UK Government approval only granted after comprehensive Consultation, Application, Examination process (between 2010 and 2014)
- Input from broad range of statutory bodies and local councils
- Environmental Impact Assessment of all offshore and onshore elements of scheme
- Complex and heavily populated area - lots of issues to address

6. Project Overview



- 13km from shore south of Brighton
- Water depths 20-40m
- 116 x 3.45MW MVOW turbines on monopile foundations
- Total 400MW capacity
- Single offshore substation on jacket foundation
- 150kV export cable
- 27km underground onshore cable
- New substation for 400kV grid connection, Bolney
- First South Coast offshore wind farm
- Development Consent Order (DCO) granted by Secretary of State 16 July 2014
- Round 3 Offshore Wind Lease
- Qualified for RO Grace Period
- £1.3bn investment
- 80 vessels have worked on site with 660 in the workforce at peak times

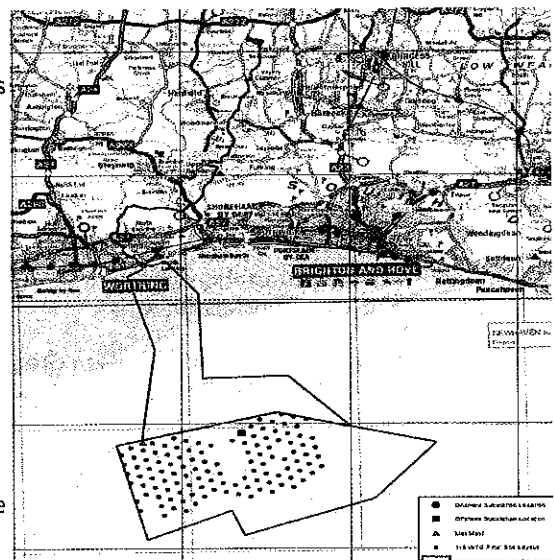

7. Project Timeline

- 2008/09: TCE bidding for Round 3 development
- 2010: TCE grant E.ON 'Zone 6' development rights
- 2010-11: Early engagement, engineering and environmental surveys
- 2012: Consultation on draft proposals
- Mar 2013: Submit Development Consent Order application
- Jun 2013: Planning Inspectorate Examination of application
- July 2014: Development Consent Award by UK Government
- May 2015: Final investment decision
- Sept 2015: Onshore Construction commences
- Feb 2016: Offshore construction commences

- *Planned*
- Oct 2017: Energise Scheme, ROC accreditation
- Mar 2018: Commercial Operations Date

8. Project Benefits

- Generate 1,366GWh power output from 'home grown' clean sustainable energy source
- Equivalent to 347,000 homes average UK homes, almost half of all the homes in Sussex
- Offset almost 600,000 tonnes CO₂ annually
- Create approx. 60 full time permanent jobs for lifetime of project (20-25 years)
- Construction workers up to 660 in construction workforce at peaks (500 peak offshore), with local supply chain opportunities benefits to local economy
- Catalyst for regeneration of Newhaven Port
- Visitor Centre on the Sussex coast with a view of Rampion, as a tourism and educational resource
- Community Benefits Scheme to support local project initiatives in Sussex

Project Certification – Way to Success in offshore Wind

項目認證- 通向離岸風電的成功之路

Why do we need Project Certification? 為什麼我們需要項目認證？

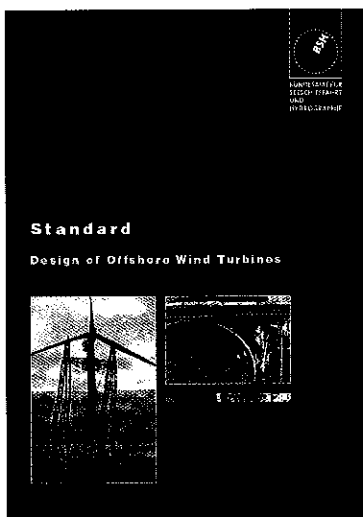

*The offshore wind turbine including the structures used for its foundation and the transformer substation as well as cabling within the farm **shall be inspected by an [...] certifier** recognised by the BSH [...]. The inspection shall be completed with a **confirmation to be presented to the BSH**. The confirmation shall contain an expert's declaration that **the overall project**, a technical system or a component of such has been configured **in accordance with the generally recognised rules** of technology or, failing that, the current state of scientific progress.*

Definition of Certification 認證的定義

Long Version:

According to the international standard **EN ISO/IEC 17000**, certification is third-party attestation related to products, processes, systems or persons, whereas attestation includes the issue of a statement, based on a decision following the review, that fulfillment of specified requirements (e.g. guidelines, codes and standards) has been demonstrated. The review itself covers verifications of the suitability, adequacy and effectiveness.

In other words:

Certification is the confirmation of compliance of a product or service in accordance with defined standards or rules.

06.09.2017 25

Definition of Project Certification of Offshore Wind 離岸風電項目認證的定義

acc. to DIN EN 61400-22

Project Certification

- has to approve that for a specific location a type certified WTG and its substructure complies with requirements derived from the external site specific conditions.
- has to approve that the design and the certificates are in compliance with applicable regional standards and regulations

Other components, such as the offshore substation are also part of the project certification.

26

Schedule and Content of Project Certification

項目認證的時間表及內容

Phase	Activities	Key Deliverables	Out for release reports	Approval Authority	BSP Releases	Content of Phase	TIME
Development	1. Initial survey to establish a high level overview of the project, including safety, health and environment, and a preliminary risk assessment.	1.1.1. Initial survey report	1.1.1.1. Safety and health of employees, the public and the environment	1.1.1.1.1. Report by the BSH* (1/1 release)	1. BSH	Meteocean data, Wind data Preliminary Soil Investigation Design Basis Preliminary Found Design	~1/2 year
	2. Detailed design and construction of the project, including safety, health and environment, and a preliminary risk assessment.	2.1.1. Detailed design and construction report	2.1.1.1. Safety and health of employees, the public and the environment	2.1.1.1.1. Report by the BSH* (1/1 release)			
Design	3. Main design and construction of the project, including safety, health and environment, and a preliminary risk assessment.	3.1.1. Main design and construction report	3.1.1.1. Safety and health of employees, the public and the environment	3.1.1.1.1. Report by the BSH* (1/1 release)	2. BSH 3. BSH	Main Soil Investigation Design Loads, Basic Design FOU, WTG, EOS, EAC Final Design FOU, WTG, EOS, EAC, Erection Hand Books HSSE	parallel to design development ~1 -1,5 year
	4. Final design and construction of the project, including safety, health and environment, and a preliminary risk assessment.	4.1.1. Final design and construction report	4.1.1.1. Safety and health of employees, the public and the environment	4.1.1.1.1. Report by the BSH* (1/1 release)			
Implementation	5. Survey of the project, including safety, health and environment, and a preliminary risk assessment.	5.1.1. Survey report	5.1.1.1. Safety and health of employees, the public and the environment	5.1.1.1.1. Report by the BSH* (1/1 release)	Operations	Survey of: - Manufacturing - Transport - Installation - Commissioning	parallel to each phase ~ 2 years
	6. Commissioning of the project, including safety, health and environment, and a preliminary risk assessment.	6.1.1. Commissioning report	6.1.1.1. Safety and health of employees, the public and the environment	6.1.1.1.1. Report by the BSH* (1/1 release)			
Operation	7. Periodical inspections of the project, including safety, health and environment, and a preliminary risk assessment.	7.1.1. Periodical inspection report	7.1.1.1. Safety and health of employees, the public and the environment	7.1.1.1.1. Report by the BSH* (1/1 release)		Periodical Inspections	
Decommissioning	8. Decommissioning of the project, including safety, health and environment, and a preliminary risk assessment.	8.1.1. Decommissioning report	8.1.1.1. Safety and health of employees, the public and the environment	8.1.1.1.1. Report by the BSH* (1/1 release)			
	9. Final decommissioning of the project, including safety, health and environment, and a preliminary risk assessment.	9.1.1. Final decommissioning report	9.1.1.1. Safety and health of employees, the public and the environment	9.1.1.1.1. Report by the BSH* (1/1 release)			

06.09.2017 27

Project Certification scheme according to IEC 61400-22

符合IEC 61400-22標準的項目認證方案

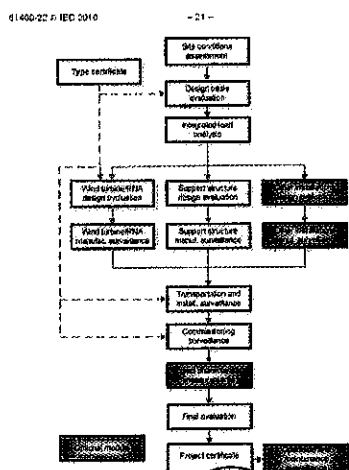

06.09.2017 28

General procedure of certification (Document review) 一般認證程序（文件審查）

Before the certification starts:

1. Inform the supplier about the certification process
2. Define the documents, which have to be submitted
3. Define the format, content and quality of the documents

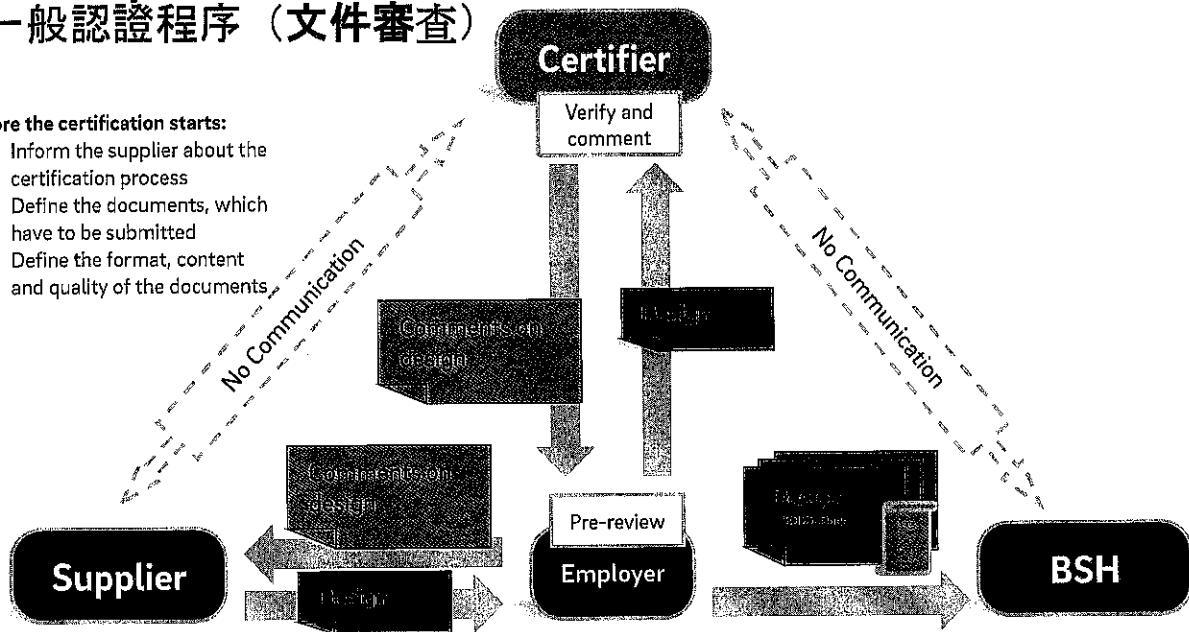

Conclusion – Take Away 結論

- Certification does concern every technical package.
- Certification will be executed through all phases of the project.
- Let's take advantage of project certification:
 - independent assessment of the whole project
 - increases of quality of suppliers and the project
 - cost saving, as per minimizing the exposure to unexpected failures
- Let's prepare ourselves and our suppliers for the process
 - to make a challenging time schedule possible
 - to reduce costs and keep them within target
 - to achieve the goals with the permitting authorities.

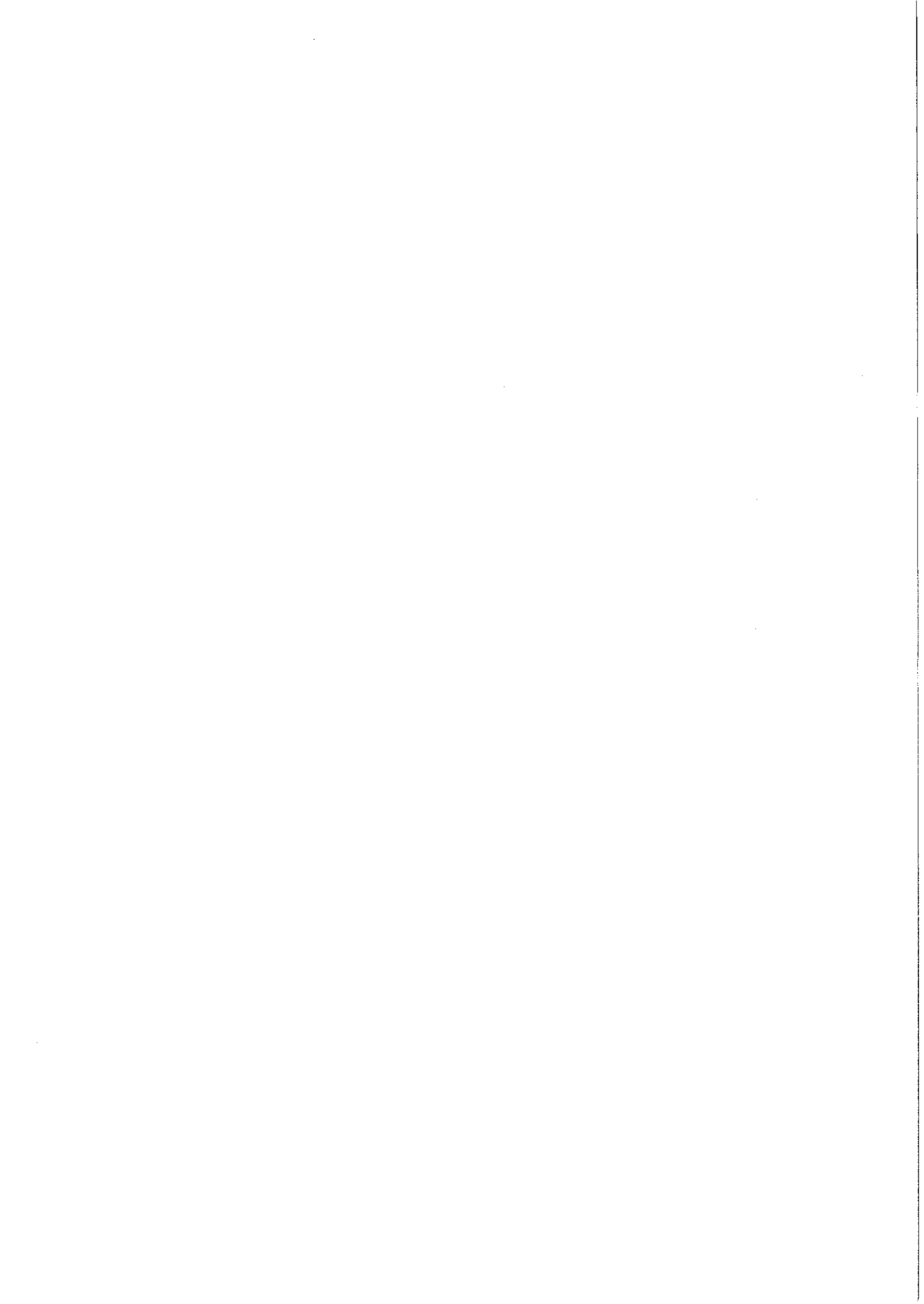

Technical Development & Construction of Rampion

Naren Mistry - Engineering Manager

6th September 2017

e-on

Green
Investment
Bank

ENBRIDGE

Presentation Overview

1. Rampion Project Scope
2. Site Characteristics
3. Final Project Design
4. Design Certification
5. Supply Chain & Logistics
6. Site Preparation
7. Monopile WTG foundations
8. Wind Turbines
9. Offshore Substation
10. Export & Array Cables
11. O&M Building
12. Construction progress

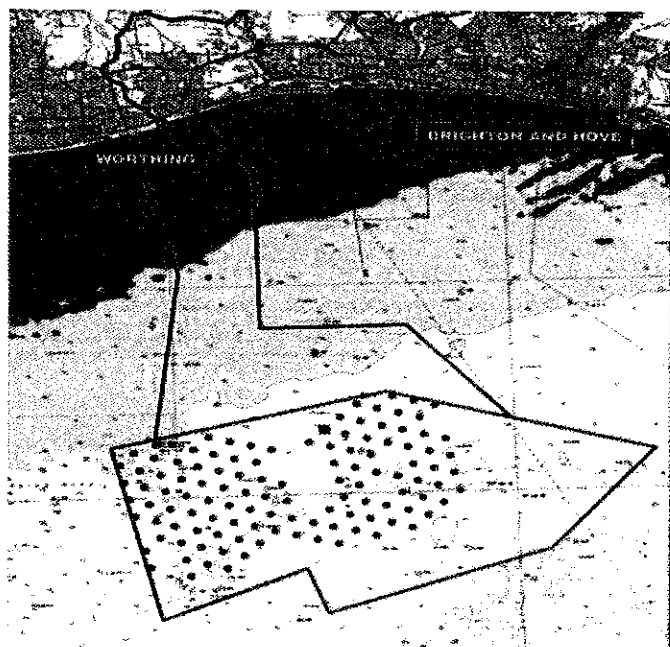

Project Scope

Wind Turbine Generators

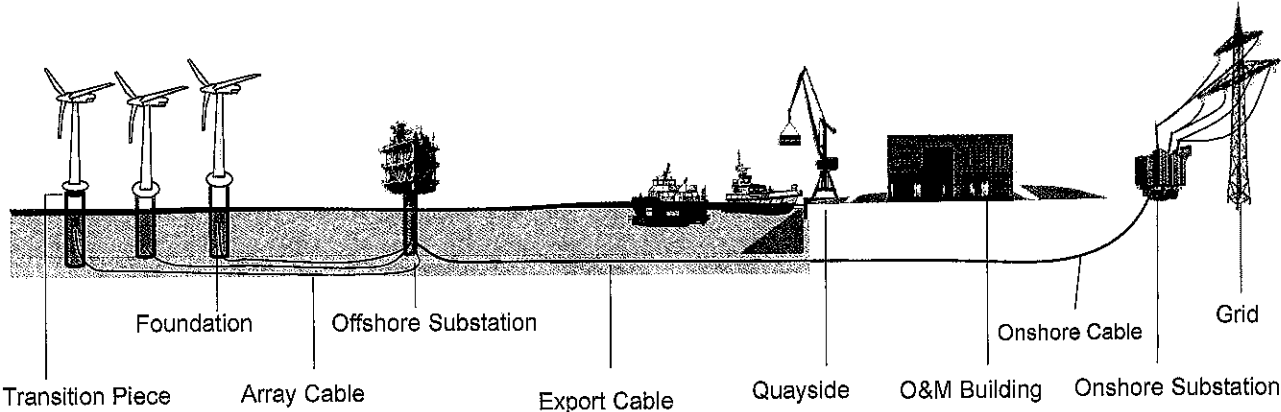

Offshore Site Characteristics

Paleochannels – infilled former river valleys

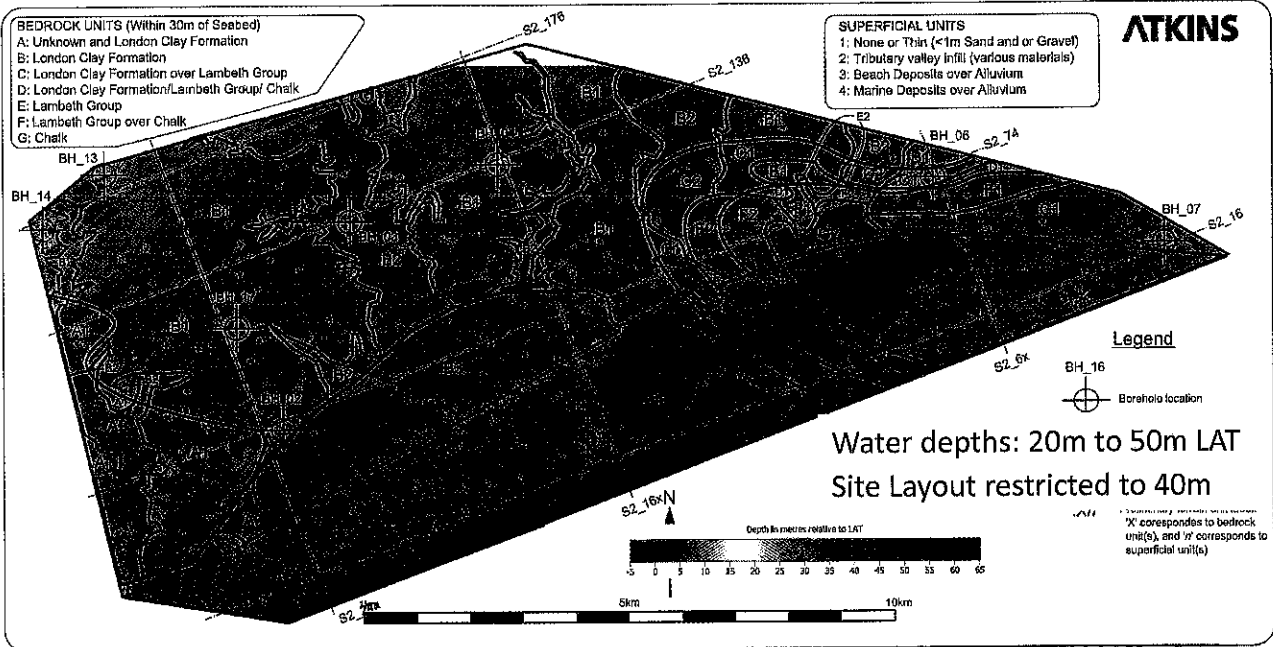

Seabed Geology

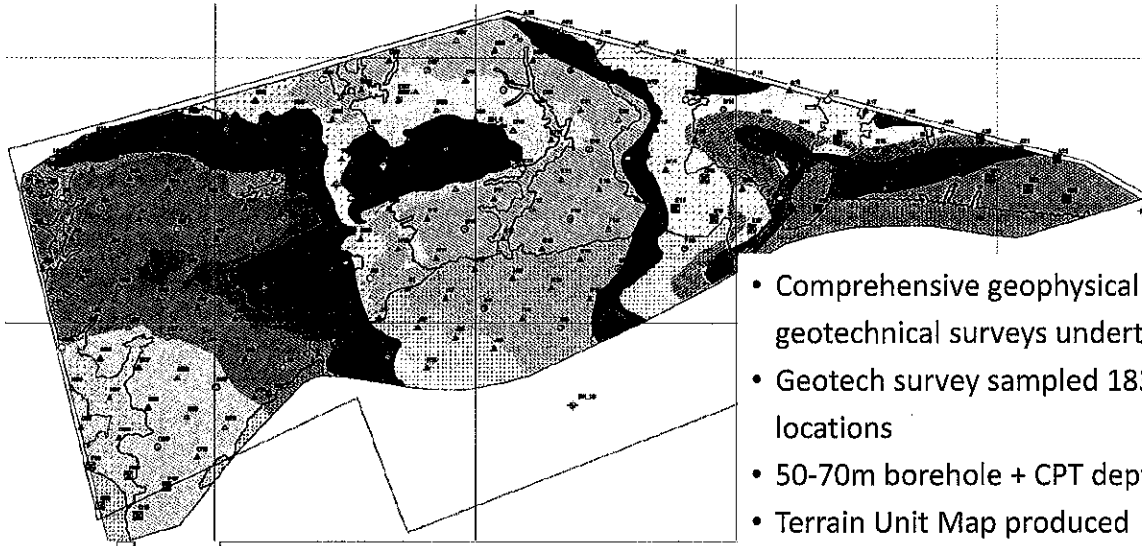

- Comprehensive geophysical and geotechnical surveys undertaken
- Geotech survey sampled 183 locations
- 50-70m borehole + CPT depths
- Terrain Unit Map produced
- Optimum 116 locations chosen

- Variety of dense sands, stiff clays
- Chalk to east of site
- Paleochannels in centre of site
- No mobile sandbanks or global scour risk expected

Rampion
Offshore Wind

Offshore design development

- Layout designed avoiding major paleochannels
- Optimised for best wind resource using modelling
- Reduced visual impact
- Lessons Learnt from previous Projects incorporated
- Proven technologies – Vestas WTG, monopile foundations
- Installable with proven vessels (MPI) and methods

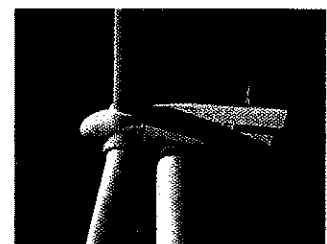

Evolution of proven machines (similar to Robin Rigg, Humber Gateway)

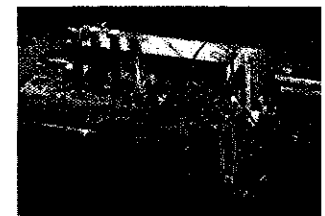

Monopile foundations: steel tube + Transition Piece

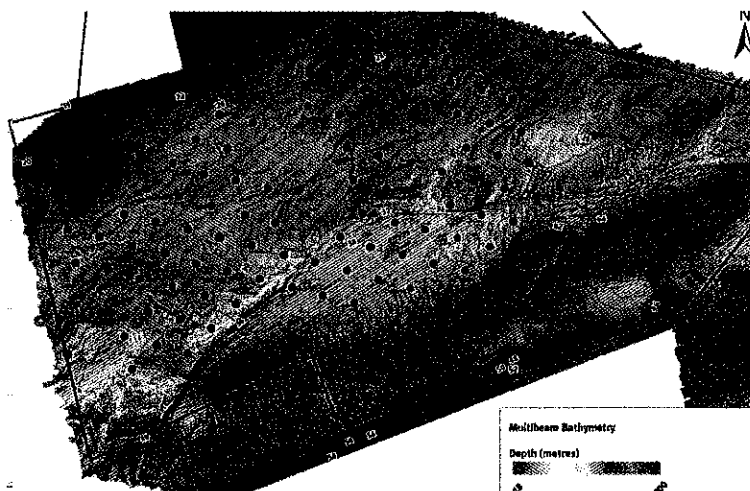

Rampion
Offshore Wind

Final design details

- 13-20km off Sussex coast / 72km² site area
- 400MW installed electrical capacity
- 116 No. x 3.45MW Vestas turbines on monopile foundations piled into the seabed
- Hub height 84m / Tip height 140m / Blade length 55m / Rotor diameter 112m
- 12 strings of 33kv subsea array cables
- Offshore Substation on four-leg jacket foundation transforms power 33kv to 150kV
- 2 x 150kv subsea export cables from OS to landfall at Brooklands Park, Worthing

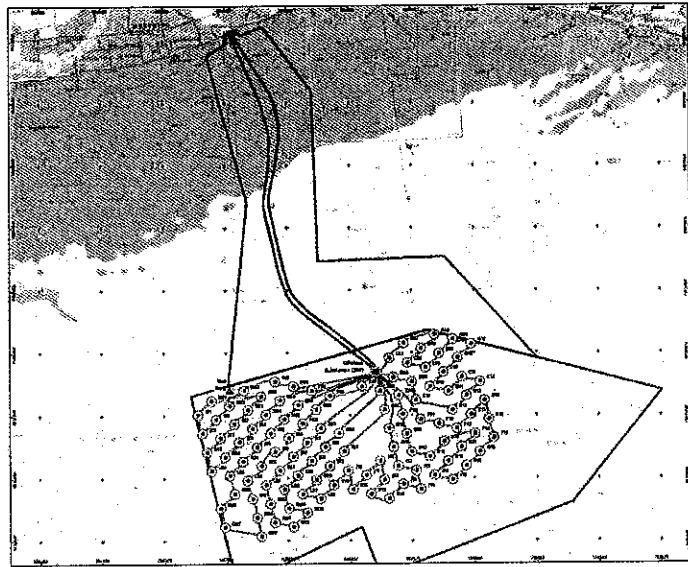

- 27km underground onshore cable route via 2 x circuits to Twineham
- Onshore substation transforms power to 400kV to connect into national transmission grid at Bolney Substation



Design Certification

Element	
Wind Turbines and towers	V112 3.45MW nacelle and rotor assembly Type Certified to IEC WT01 by DNV GL WTG Tower design evaluation to DNV J101 and IEC 61400-3 Certified by DNV GL WTG certification arranged by wind turbine supplier
Wind Turbine Foundation	Bureau Veritas have issued Evaluation Reports and Certificates of Conformity for the Design Basis, integrated design of the support structure and the Site-specific Design evaluation.
Offshore Substation Topside and jacket	Bureau Veritas are certifying the design of the primary steel and fire systems for the topside and Jacket structure. Substation equipment is designed and tested to relevant IEC standards. Where equipment is containerised, containers are designed to DNV 2.7
Offshore Array cables	Cables rated in accordance with IEC60287 Cables Type Tested in accordance with IEC 60502, Cigre 490 and Cigre 701
Offshore Export Cables	Cables rated in accordance with IEC60287 Cables Type Tested in accordance with IEC 60840, Cigre 490 and Cigre 701
Onshore Export Cables	Cables rated in accordance with IEC60287 Cables Type Tested in accordance with IEC 60840
Onshore Substation	Substation designed in accordance with National Grid Technical Standards (NGTS). Where applicable NGTS do not exist (i.e. for 150kV equipment), relevant IEC standards shall be applied. Equipment connecting directly to NGET assets (400kV cables) will by Type Registered in accordance with National Grid requirements.

Supply Chain & Logistics

Rosyth, UK
Babcock Offshore
Substation Platform

Barged to site and
Installed by Rambiz
3000 HLV



Teeside, UK
MPI base port
JDR Array Cables.
Collected by Fugro
Symphony cable
installation vessel

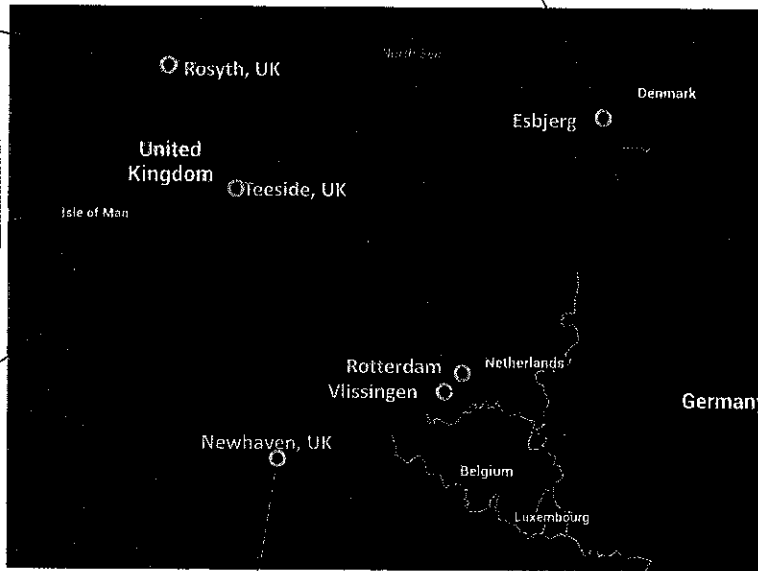

Esbjerg, DK
WTG Pre-Assembly Harbour
Secured as part of WTG Contract

465 nautical miles from Rampion
8 WTGs per cycle on MPI Discovery (right)



Rotterdam, NL
HSM (part of Babcock
contract) Substation Jacket

Vlissingen, NL
Foundations Staging Port
Verbrugge Terminal
Staging Port for Foundations

160 nautical miles from Rampion
3 foundations/cycle MPI Discovery
4 foundations/cycle Pacific Orca
(below)



Newhaven, UK
Construction Project Management Base
10 nautical miles from Rampion

From Korea: LS Cables
marine export cables

Boulder relocation

- Relocate boulders down to 30cm in diameter
- Approx. 12,000 boulders relocated
- Haphazard relocations to prevent reef
- Informing fishermen of new boulder locations

Below: Pegagus

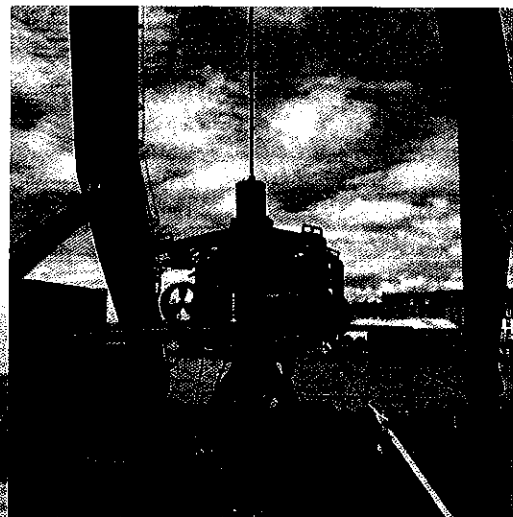
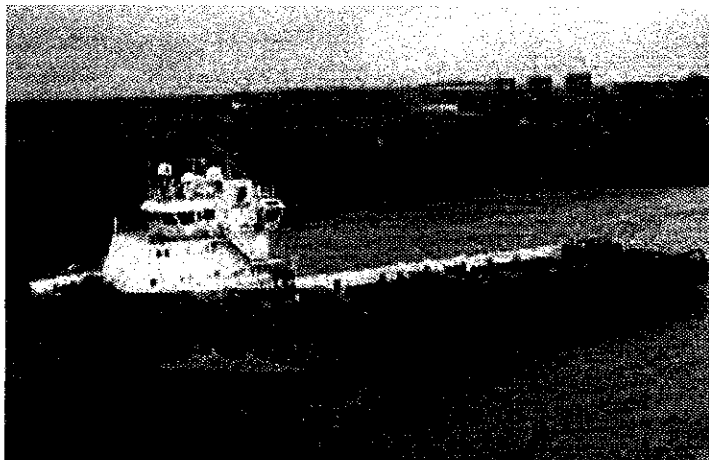

Above: Rock grab UTROV

UXO (unexploded ordnance)

- 1,200 potential targets surveyed, primarily looking for WWII unexploded ordnance
- Detailed analysis of ultrasonic magnetic targets to discount non-explosives
- Remote Operating Vehicle (ROV) examination of remaining targets
- Divers assess last remaining targets

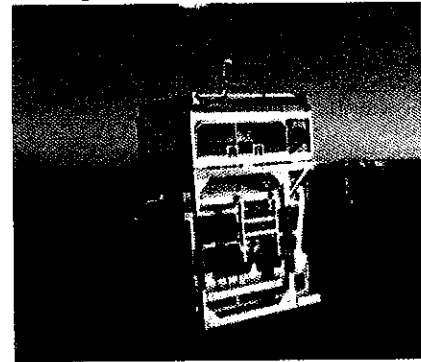
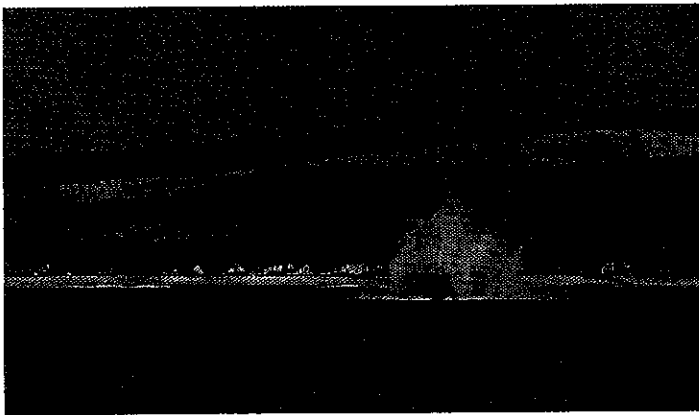

- 2 x WWII 500lb bombs identified 3km off Lancing beach, 13m water depth
- Routine controlled explosions in August 2016 following MMO consultation



Construction Project Management Base

- Temporary Construction Base at Newhaven Port
- Marine co-ordination centre
- Quayside floating pontoon access
- Crew Transfer Vessels (CTVs) operating from Newhaven Port, Shoreham Port and Brighton Marina



Monopile WTG Foundation Design

– Designer – LIC Energy (Bristol)

– Monopiles (MP):

5.75m to 6.5m diam at toe

60m to 85m length

550 to 830 Tonnes

Individually designed for location

– Transition Pieces (TP):

Standardised design

250 Tonnes

Top platform 20m above HAT

Internal cable routing

Boat landing giving access from CTV

Flanged bolted connection TP to MP

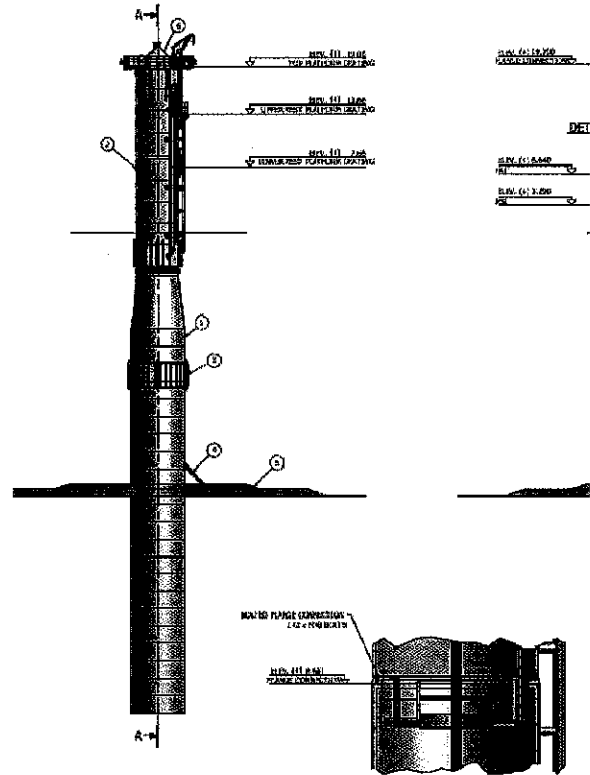

Foundation Fabrication

Monopile Fabricator : SIF (Netherlands)

- Manufactured in Roemond
- Transported by barge & stored in Vlissingen

Transition Piece Subcontractor : Smulders (Belgium)

- Manufactured then stored in dry dock in Antwerp

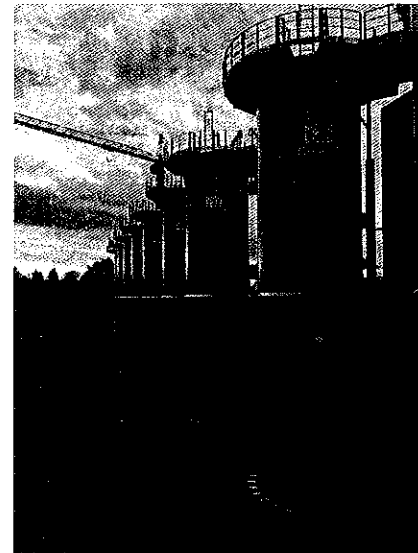

Monopile installation

- Jan '16: MPI 'Discovery' jack up vessel - load out from Vlissingen, Netherlands
- End Jan: 'Discovery' arrived on site with first 3 x monopiles and transition pieces

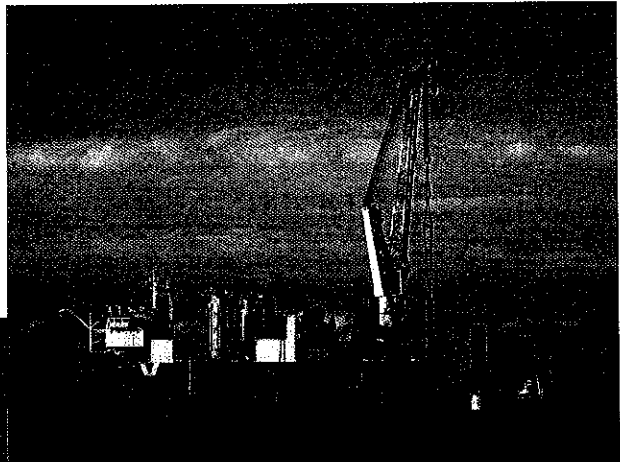
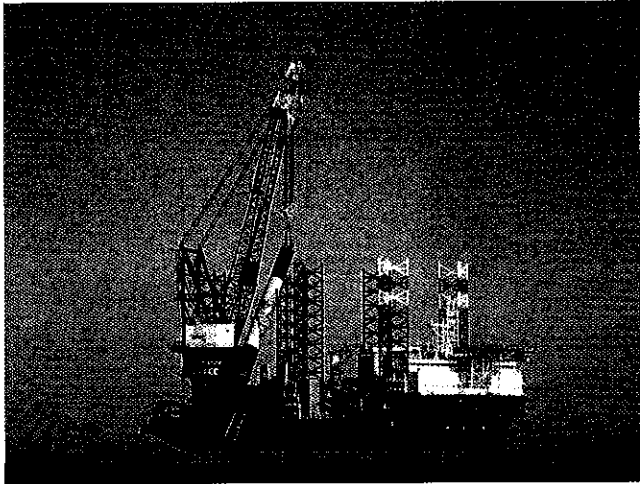

- Mid April – End June : No pile driving to protect black bream spawning
- 1st July: SBO 'Pacific Orca' joined MPI 'Discovery' to complete installation



Monopile installation

- Monopile hammer time 2-4 hours
- Foundation completion 24-36 hours
- 1000T cranes to lift monopiles
- Completion target was early 2017
- All 116 foundations installed by 9th November 2016.

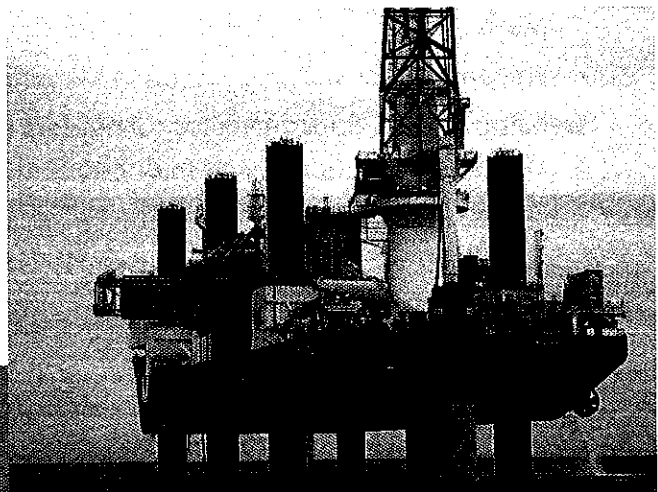

Wind Turbines



- Contract awarded to MVOW (Denmark)
- Design, manufacture, pre-assemble, loadout and commissioning of 116No. wind turbines
- 3.45MW Vestas turbines
- 112m rotor diameter, 140m to blade tip
- Integrated design of tower and foundation by Vestas & LIC Energy
- Pre-assembly at Esbjerg, Denmark

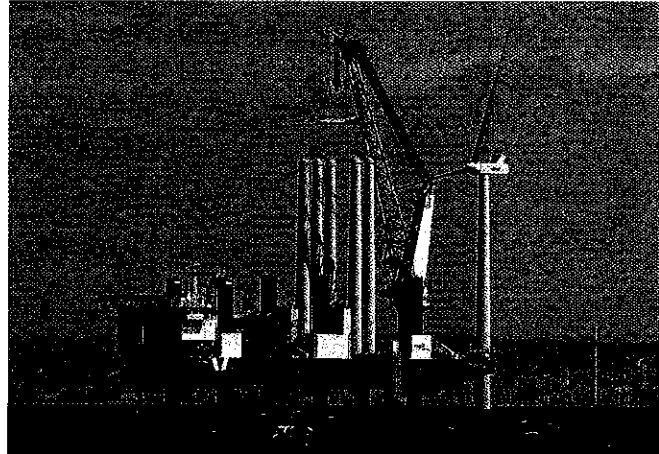

Offshore Substation Design

- Design & Fabrication – Babcock (Rosyth)
- 4-leg Jacket foundation
- Topside with cable deck
- Topside plan area – 42m x 38m
- Topside weight – 2000 tonnes
- 2No. 150kV/33kV Transformers
- 150kV GIS & 33kV Switchgear
- Control Rooms
- Heli-hoist area
- Emergency accommodation
- 12 array cable j-tubes
- 2 export cable j-tubes

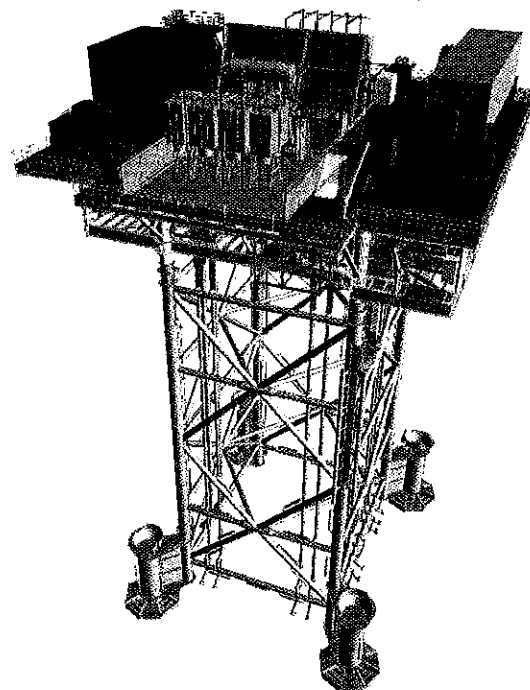

Offshore Substation Fabrication

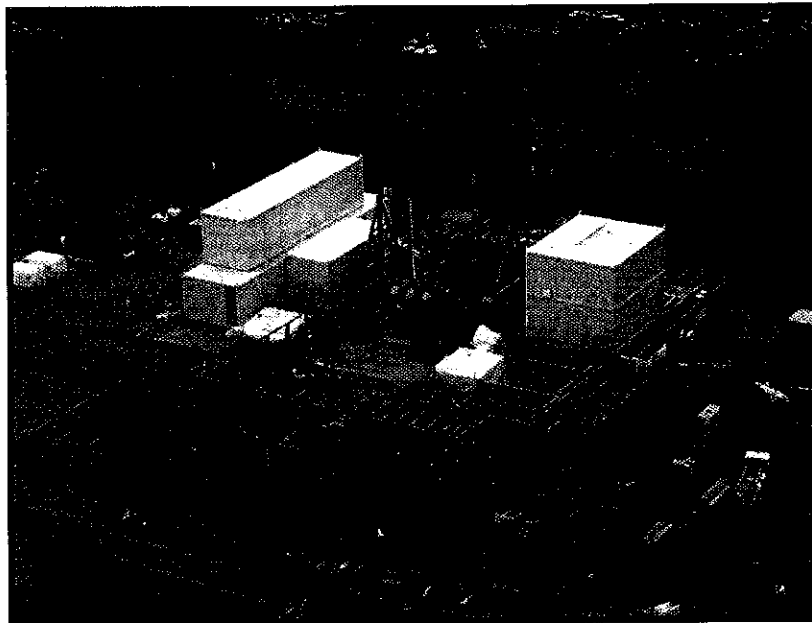

- Rampion OSP Fabrication in Babcock's shipyard in Rosyth



Substation Foundation installation

- Steel jacket foundation - 900 tonnes
- Fabricated by HSM in Rotterdam
- Installed by 'Rambiz' in September 2016
- Four pin piles to connect jacket to seabed

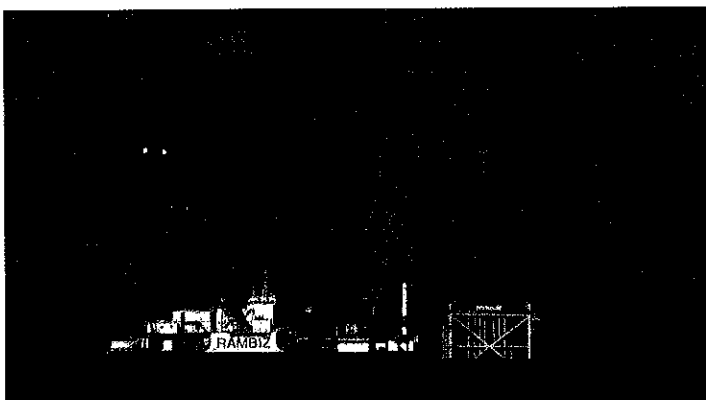
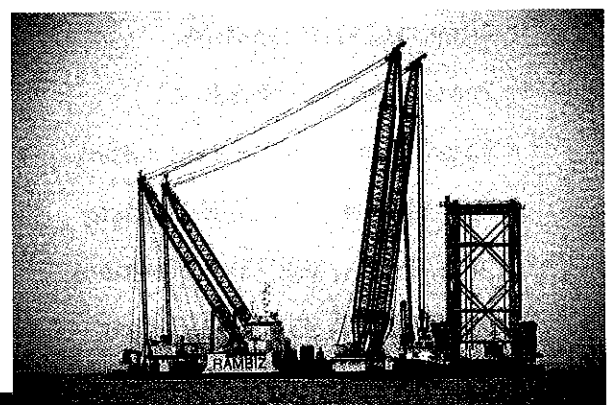

Substation Topside installation

- Topside final weight 2000 Tonnes
- Loaded out and transported by barge from Rosyth to Southampton
- 'Rambiz' arrived and set up on site
- Topside barged to site and lifted onto foundation by Rambiz in April 2017

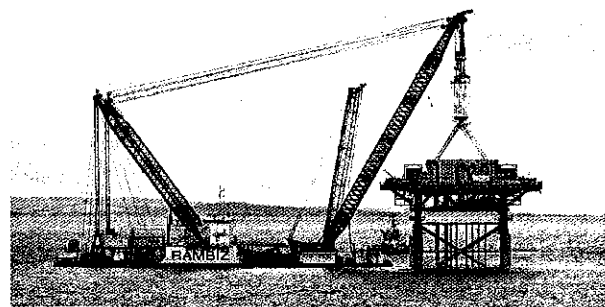
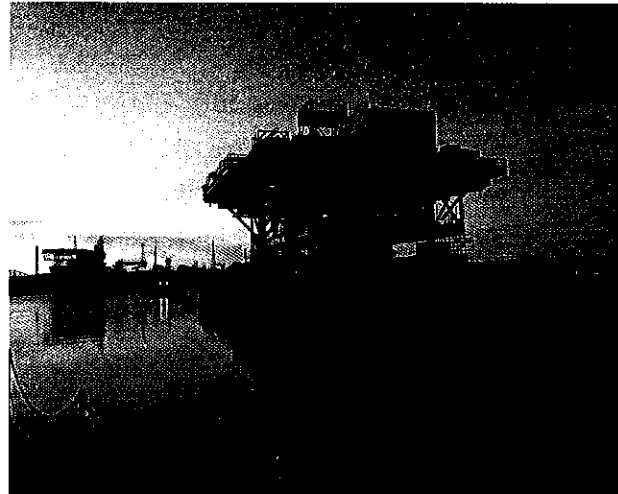

Array Cable layout

- 12No. Strings connecting 8 or 10 turbines per string,
- backlinks between pairs of strings

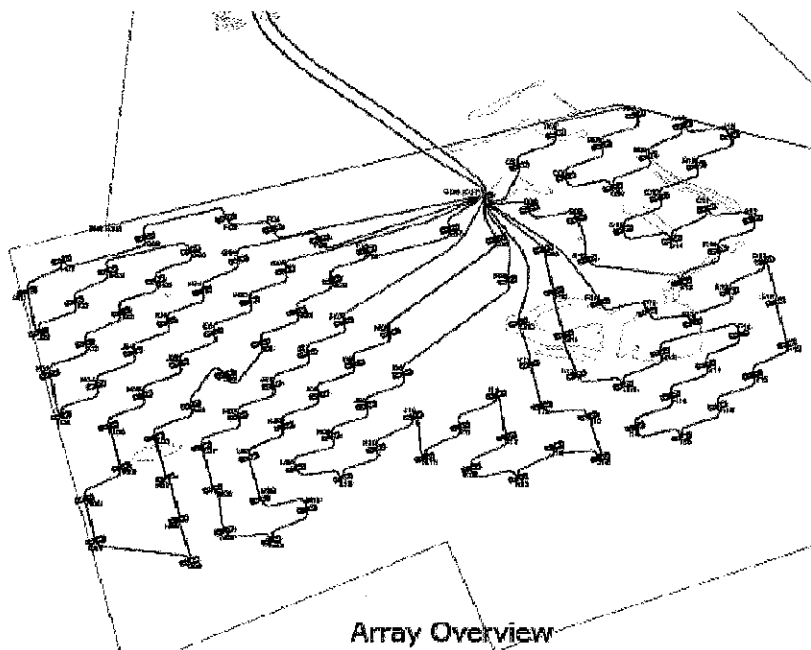

Array Cables Supply

- JDR Cables (Hartlepool)
- Design & manufacture of 140km of 33kV sub-sea inter-array cables
- 3 core copper cables with fibres
- 150mm² & 400mm² core sizes
- Loaded out onto installation vessel
- Supply of Cable Protection System

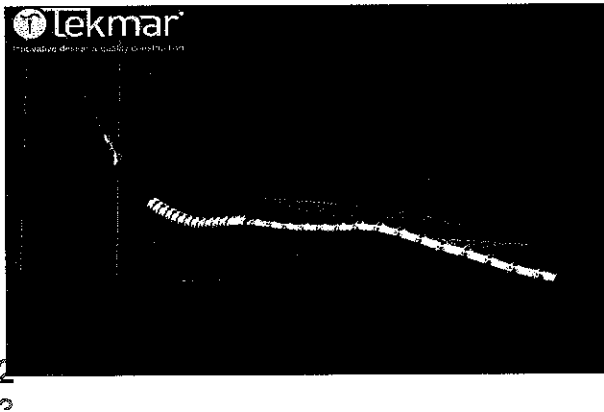
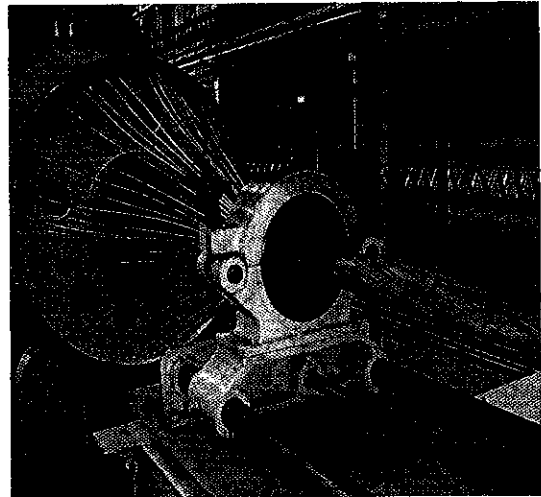

Array cable installation

- First campaign: Aug - Oct 2016 - 71 No. installed
- Second campaign started April 2017 – Remaining 69 No.
- Fugro 'Symphony' (below) collect, lay and pulling-ins
- Fugro 'Saltire' used for burying cables using jetting and ploughing (Q1400 plough, right)
- Target depth of burial 1m, minimum depth 0.5m



- Where the minimum depth is not achieved, rock bags are to be installed to protect the cables

Export Cable Supply

- Supplier: LS Cables (South Korea)
- Design, manufacture, loadout & transport
- 2No. 150 kV Export Cables,
- Cables 19km and 17km long
- 3 core Aluminum cables with fibre optics
- 1200mm² and 1600mm² cores
- 240 & 250mm dia, 95 & 100kg per m
- Loaded out to Cable Supply Vessels in Donghai, South Korea
- Transpoled to Cable Laying Vessel in Netherlands

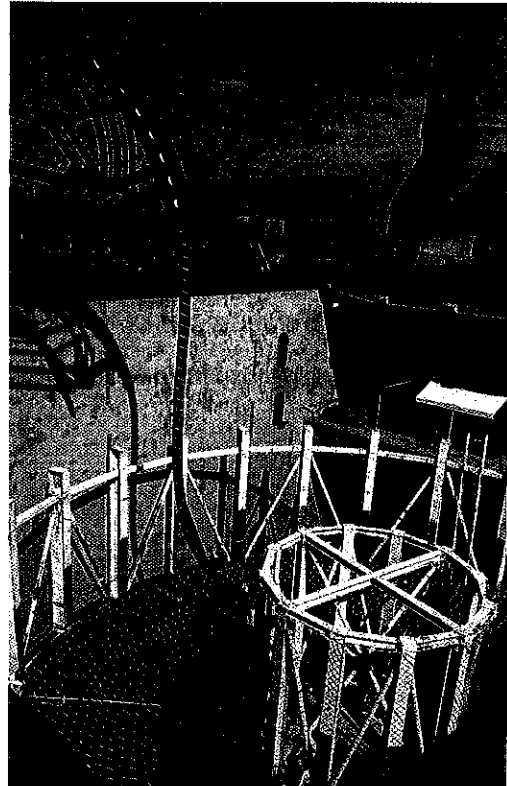

Offshore Export Cable Installation

- Contract awarded to VBMS (Netherlands)
- VBMS 'Stermat Spirit' installation vessel
- Scope included transpool, lay and burial
- Cables pulled ashore through pre-installed HDD and duct extension
- Offshore the cable then simultaneous laid and buried by subsea plough pulled from the installation vessel
- 1st Export cable installation completed in Oct
- 2nd Export cable installation completed in Nov

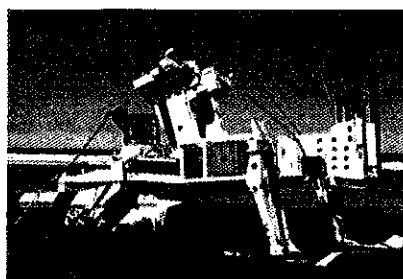
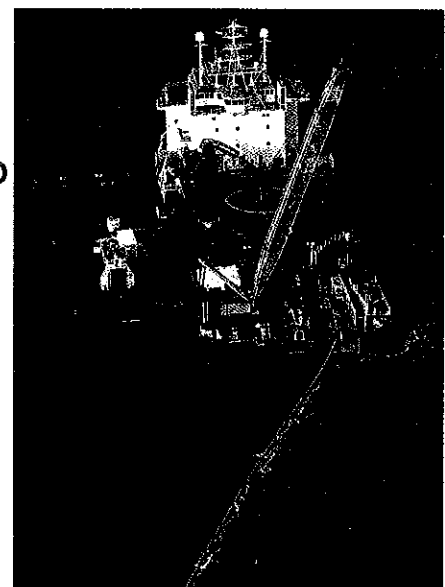

Operations & Maintenance Base

- Rampion Operations & Maintenance Base located at Newhaven Port
- Two storey office including control room, meeting rooms, mess and changing facilities for 60 staff
- 750m² warehouse with direct access to quayside with 120m pontoons for CTV berthing
- Two quayside cranes for loading and vessel refueling facilities

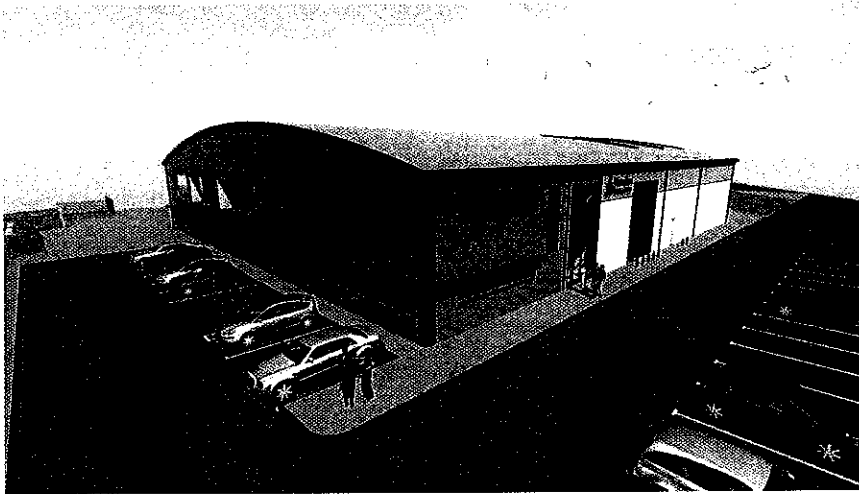

Construction Progress

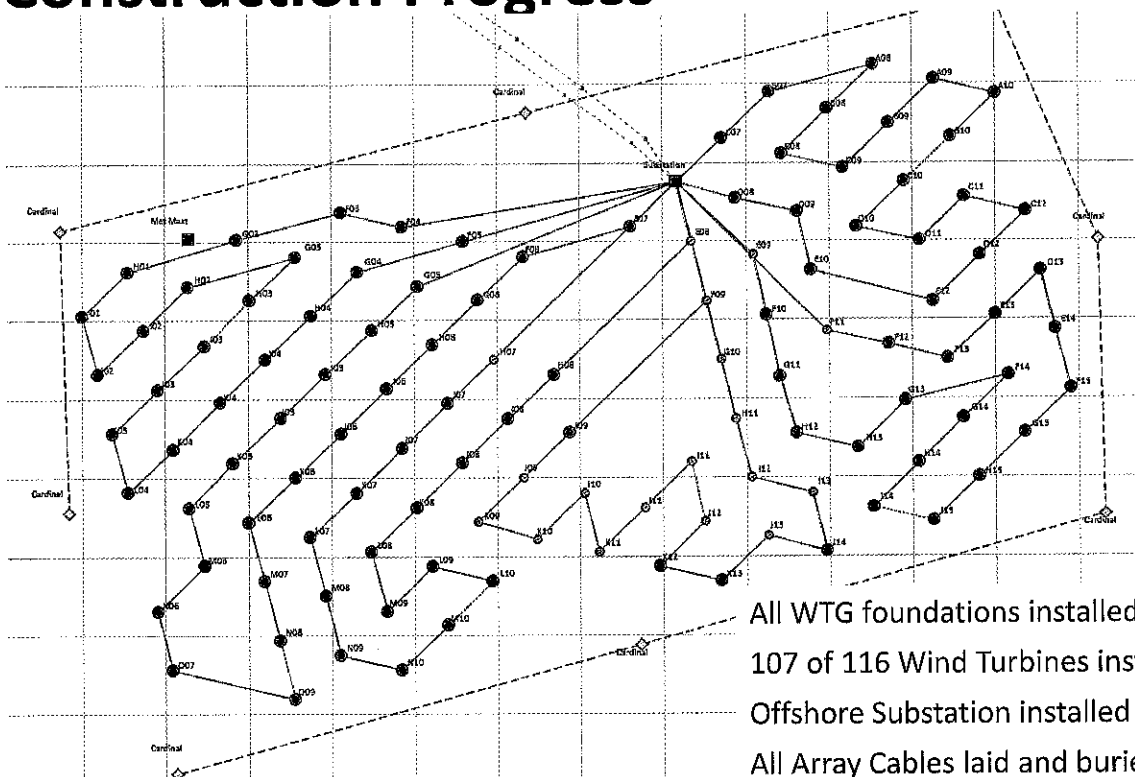

All WTG foundations installed
107 of 116 Wind Turbines installed
Offshore Substation installed
All Array Cables laid and buried
Both Export Cables laid and buried

Rampion Offshore Construction Video

Video footage showing:

1. Monopile foundation fabrication and installation
2. Export Cable duct extension installation
3. First wind turbine installation

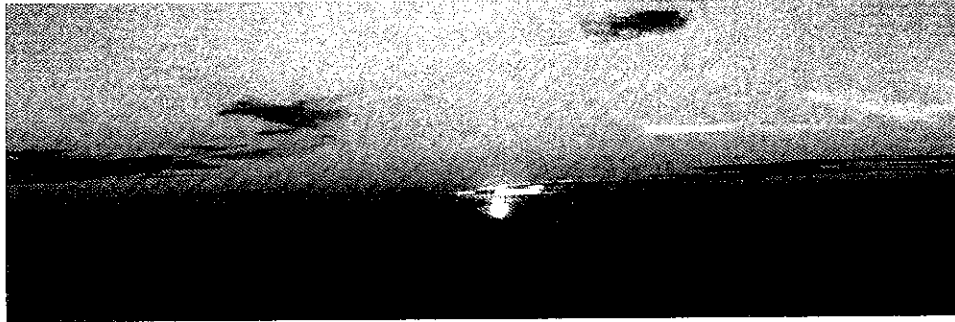

 **Rampion**
Offshore Wind

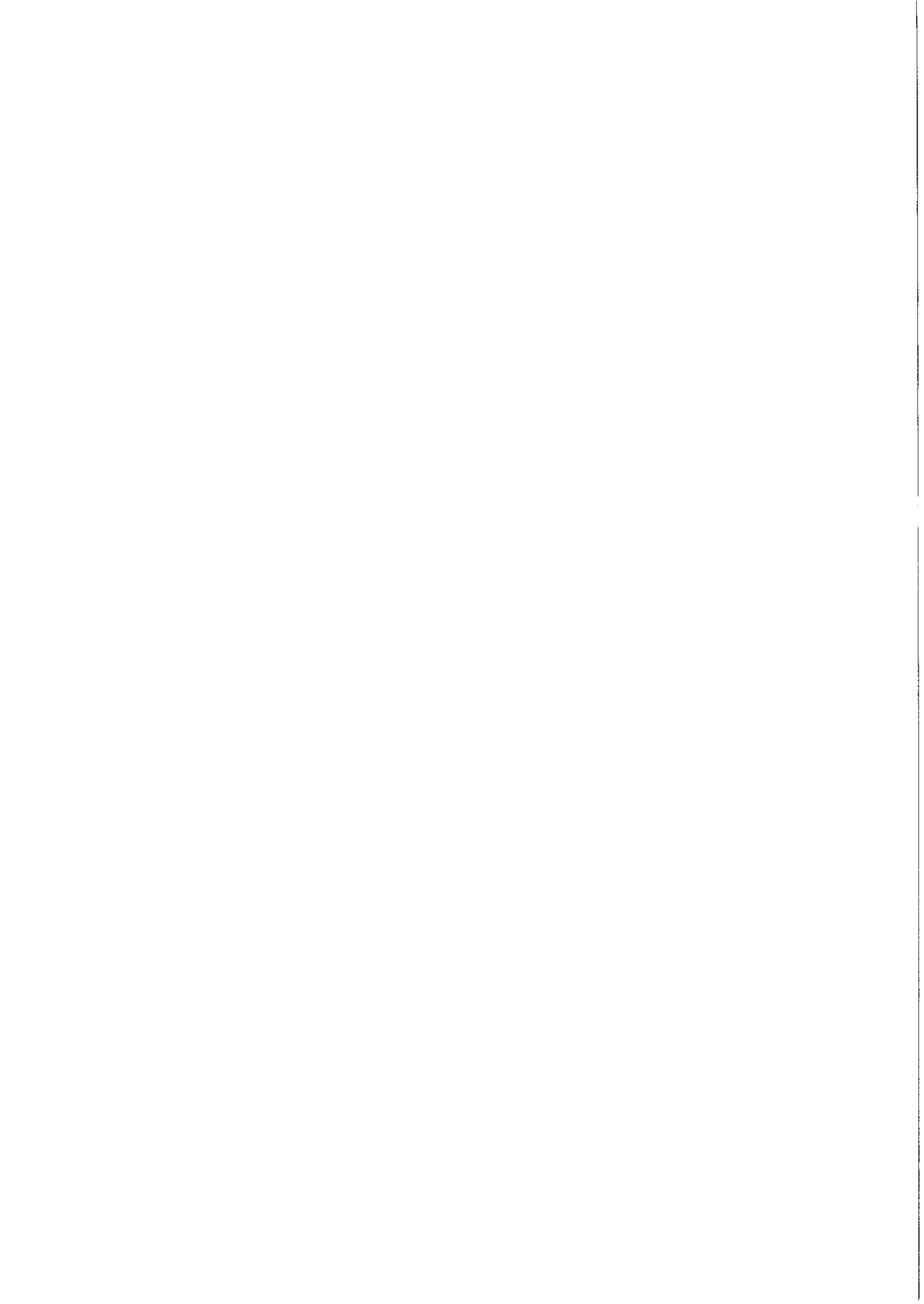



LOC Group LOC Renewables

Peter Croll & Dr RV Ahilan
Brighton, 6th September 2017

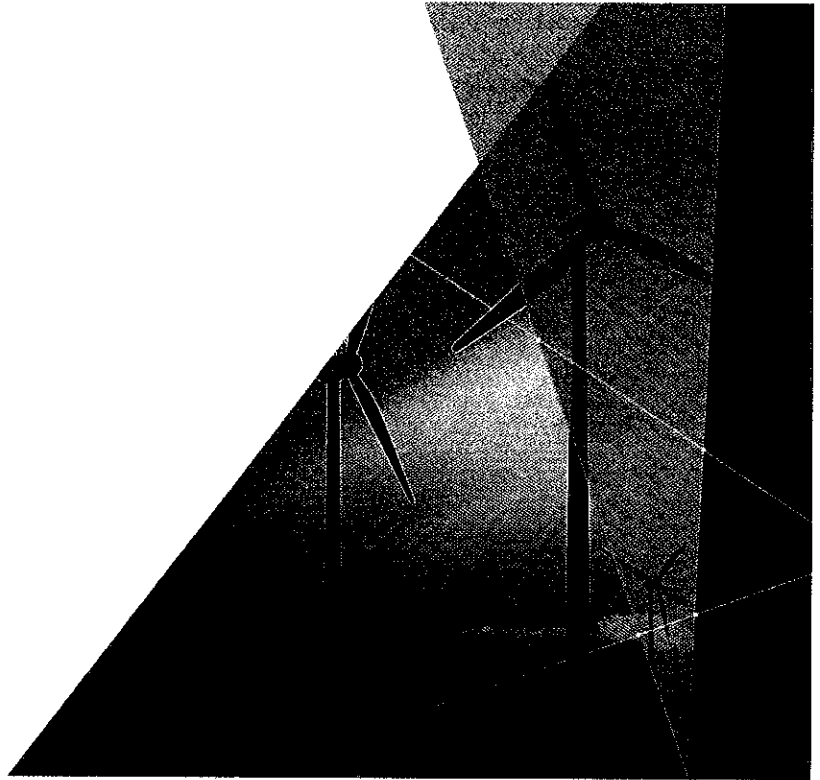

ONE PARTNER. WORLDWIDE SUPPORT.

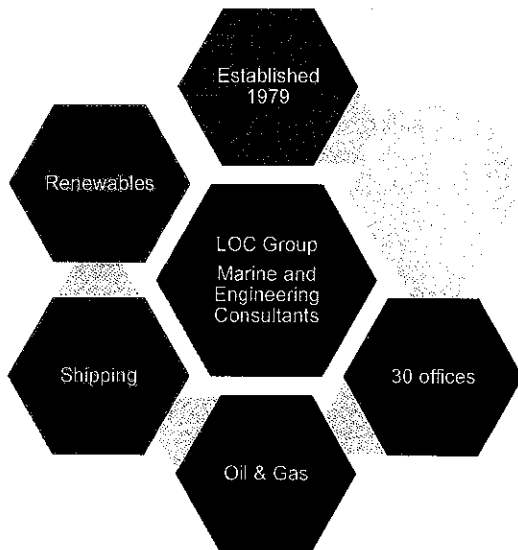

Skillset

- Naval Architects
- Master Mariners
- Civil & Structural Engineers
- Marine Engineers
- Mechanical Engineers
- Geotechnical Engineers
- Metocean Engineers
- Hydrodynamicists
- Subsea, Cable & Pipeline Engineers







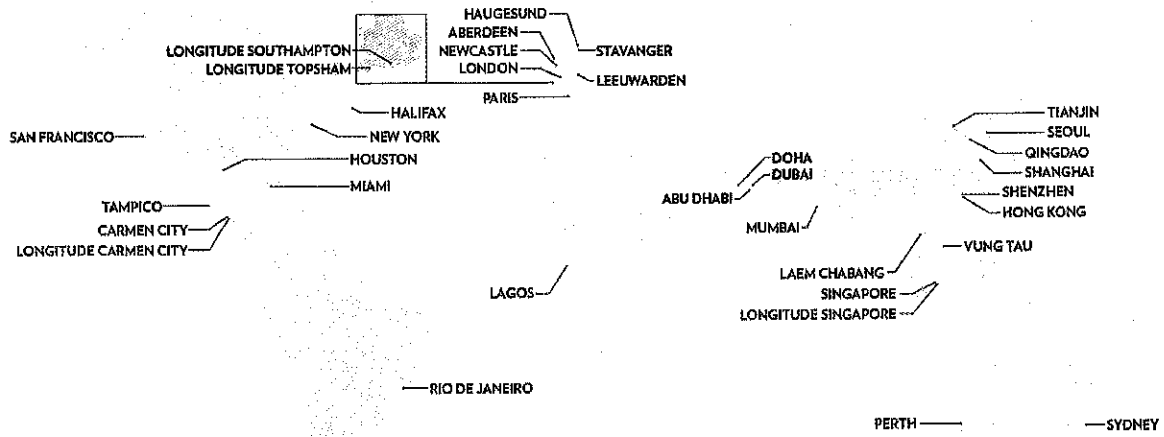

Our Locations



Our Services

-  Marine Warranty Surveys
-  Claims, Disputes & Litigation
-  Marine Casualties
-  Surveys, Inspections & Audits
-  Marine & Engineering Consultancy

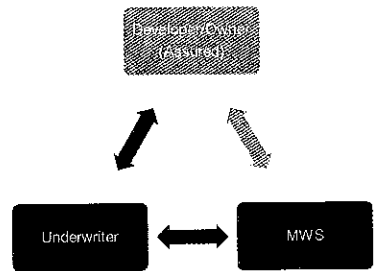



Some of Our Clients...

Shipping	Oil & Gas	Renewables
<p>The Standard </p> <p>West of England </p> <p>NORTH </p> <p>mca </p> <p>Reed </p> <p>INCE & CO </p> <p>CLIFFORD CHANCE </p> <p>MICOPERI </p> <p>gard </p> <p>Britannia </p> <p>hfw </p> <p>DentorWildeSapte... </p> <p>Clyde&Co </p> <p>SKULD </p> <p>THE CAPYLE GROUP </p> <p>WIKBORG REIN </p> <p>DLA PIPER </p> <p>HILL DICKINSON </p> <p>NORTON ROSE </p> <p>STANBUL MUTUAL </p>	<p></p> <p>INPEX </p> <p>ExxonMobil </p> <p>TULLOW </p> <p>DA </p> <p>PEMEX </p> <p>Reliance Industries </p> <p>woodside </p> <p>PETROBRAS </p> <p>ericana </p> <p></p> <p>Chevron </p> <p>TOTAL </p> <p>BECHTEL </p> <p>Skatoff </p> <p>bhpbilliton </p> <p>bp </p> <p>woodside </p> <p>Shell </p> <p>BG GROUP </p> <p>PICC </p>	<p>EDF ENERGY </p> <p>Nobelwind Offshore energy </p> <p>DONG energy </p> <p>e-on </p> <p>Balfour Beatty </p> <p>Tennet </p> <p>SIEMENS </p> <p>RWE </p> <p>Prysmian Group </p> <p>Van Oord </p> <p>A2SEA </p> <p>mpi </p> <p>Boskalis </p> <p>ALSTOM </p> <p>RAMBOLL </p> <p>seafacks </p> <p>Global Marine </p>



LOC Renewables

www.loc-group.com/renewables

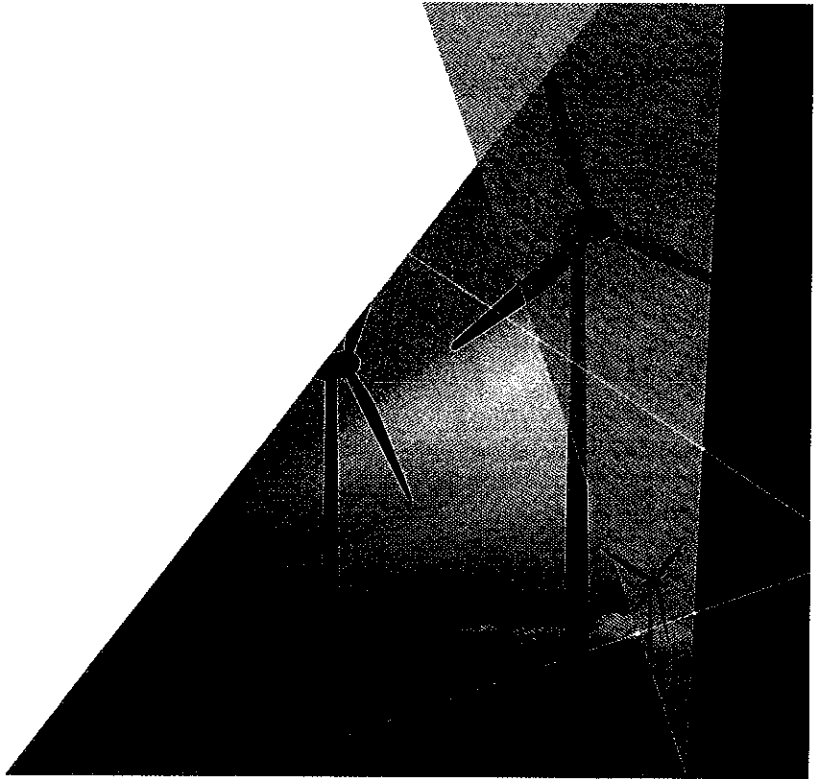



LOC Renewables – LOC and Longitude focused towards *Offshore Renewables*

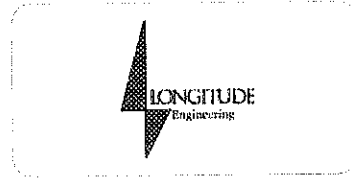

Premier independent marine and engineering firm; #1 Marine Warranty Surveyor in offshore wind



Specialist engineering consultancy dedicated to providing naval architecture, structural design and analysis services

**Headquarters in UK
Presence in 16 countries**

UK, Singapore, Mexico



Competences

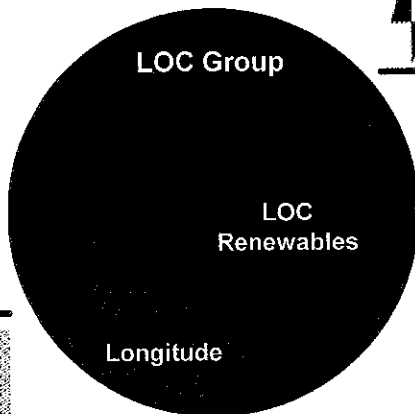

- PLAN>DESIGN>BUILD>OPERATE**
- Naval Architecture
 - Structural Design & Analysis
 - Marine Transportation
 - Installation Engineering
 - Offshore Renewable Operations
 - Mooring & Riser Design & Analysis
 - Meteorological Analysis

- PLAN>DESIGN>BUILD>OPERATE**
- Marine warranty surveys
 - Marine engineering and consulting
 - Surveys, Inspections & Audits
 - Claims, disputes and litigations
 - Marine casualties
 - Concept Design
 - Owners Engineering
 - Independent Engineering
 - Technical Due Diligence
 - Project Management





LOC Renewables Services

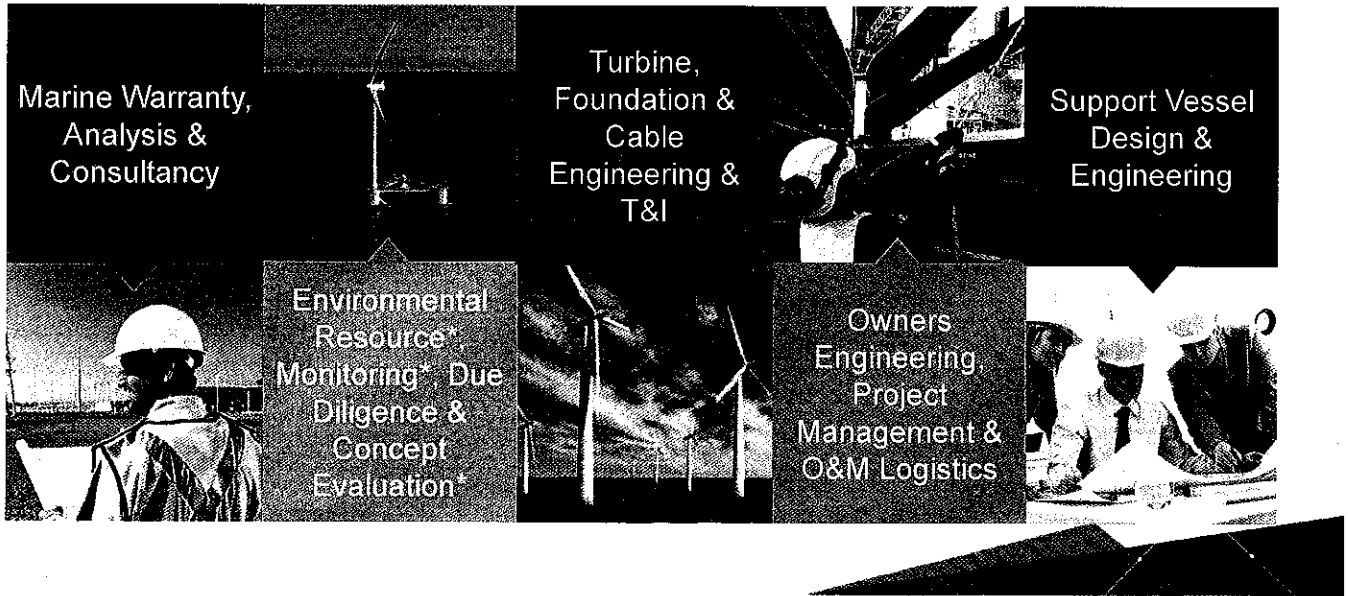

Detailed Service Offerings for Projects

DESIGN

BUILD

Planning & Permitting

- › Concept Development Pre-FEED
- › Environmental Monitoring & Impact Assessment
- › Navigation Risk Assessments in support of EIA
- › Human Impact Assessment

Wind Resource

- › Site selection and layout
- › Met mast and measurements
- › Annual Energy Production
- › Developer and/or Financier Support
- › FEED

Turbine

- › Suitability review
- › Selection and interaction with AEP
- › Tender specifications
- › Package management

Balance of plant

- › Constructability
- › Site Surveys & Investigations
- › Detailed Design
- › Tender specifications
- › Package management
- › OFTO TDD
- › HSEQ

Transport & Installation

- › Warranty Services
- › Tender specifications
- › Package management
- › Vessel SIA/SSA
- › Marine Engineering
- › Cable installation, routing, in-place

O&M

- › Management & Supervision
- › Control Room
- › Production Optimisation
- › Annual Energy Production
- › Vessel SIA/SSA
- › Logistics design

Existing capability incl. alliances
M&A Focus



Track Record Summarised as....



> 60 projects
 > 9GW
 ~ 65%

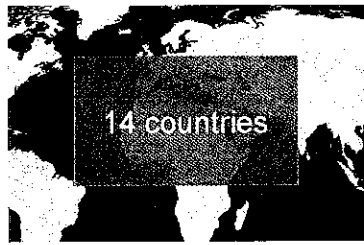

UK	Portugal
Germany	Ireland
Sweden	Belgium
Holland	USA
France	Taiwan
Denmark	Korea
Norway	Vietnam

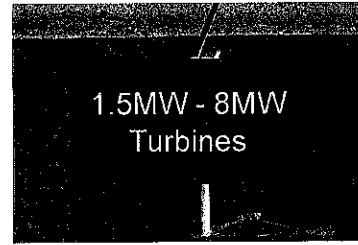

Siemens Gamesa
 MHI Vestas
 Senvion
 GE Alstom
 Areva
 Adwen
 Doosan

Reference Project Thanet Offshore Wind Farm

- Technical Due Diligence of offshore transmission assets including:
 - Design & Technology, Cable Routes & Profiles
 - Installation and Construction, Burial & Protection
 - O&M and Survey recommendations
 - Environmental Impact, quality management
 - Performance criteria
 - Foundation design, seabed morphology, scour and seabed movement
- Cable repair engineering including hydrodynamic modelling of repair vessel, mooring systems, export cable repair analysis

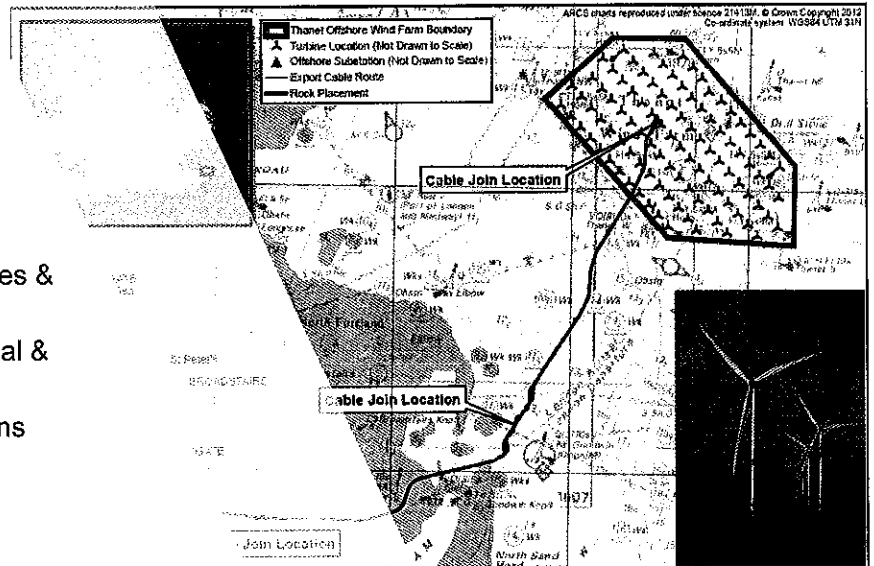

Brief Project Details

Vattenfall
 300 MW wind farm
 100 x 3MW wind turbines
 2 export cables



Industry Standards and Guidelines Published (or contributed)

- Prepared by LOC with Generating Better Ltd and published by the Crown Estate:
 - <http://www.thecrownestate.co.uk/media/451536/ei-km-in-om-construction-072014-jack-up-vessel-optimisation.pdf>
- Prepared by LOC and published by RenewableUK:
 - http://c.yimcdn.com/sites/www.renewableuk.com/resource/resmgr/publications/reports/H&S_Jackup_Barges.pdf
- LOC – Project Specific Guidelines (preliminary) – Marine Operations Installation of Gravity Base Wind Turbines Structures by a transport and installation barge “TIB” (LOCL/7041/JCT/R001 /REV 2)
- ISO 19901-6 Petroleum and natural gas industries – Specific requirements for offshore structures – Part 6: Marine operations. (Final draft - 2005)



Crown Estate Map of UK Offshore Wind Status (Dec 2016)

01	Barrow	90
02	Blyth	4
03	Burbo Bank	90
04	Greater Gabbard	504
05	Gunfleet Sands Demo	12
06	Gunfleet Sands 1	108
07	Gunfleet Sands 2	65
08	Gwynn y Mor	576
09	Humber Gateway	219
10	Inner Dowsing	97
11	Kentish Flats	90
12	Kentish Flats Ext	49.5
13	Levenmouth Demo	7
14	Lincs	270
15	London Array	630
16	Lynn	97
17	North Hoyle	60
18	Ormonde	150
19	Rhyl Flats	90
20	Robin Rigg East	90
21	Robin Rigg West	90
22	Scroby Sands	60
23	Sheringham Shoal	317
24	Teesside	62
25	Thanet	300
26	Walney 1	184
27	Walney 2	184
28	West of Duddon Sands	389
29	Westermost Rough	210

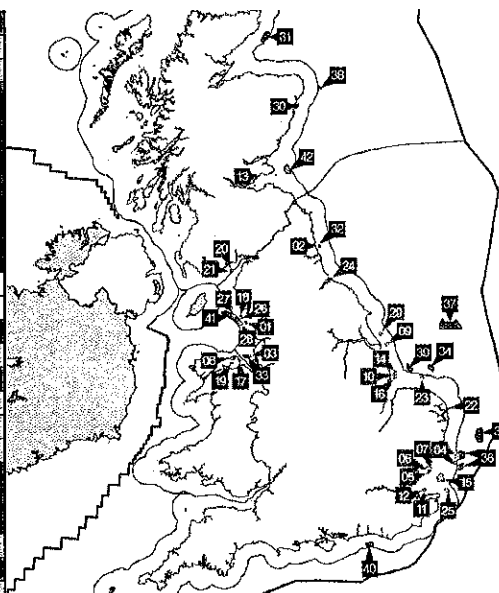

30	Aberdeen Demo	92.4
31	Beatrice	588
32	Blyth Demo Ph1	41.5
33	Burbo Bank Extension	258
34	Dudgeon	402
35	East Anglia ONE	714
36	Galloper	336
37	Hornsea Project 1	1218
38	Hywind 2 Demo	30
39	Race Bank	573
40	Ramplan	400
41	Walney Ext	659

KEY	
Operational	MWS
WF	TDD, Consulting, Engineering
Under Construction	MWS
	TDD, Consulting, Engineering





Rampion Project

LOC & Longitude Contribution

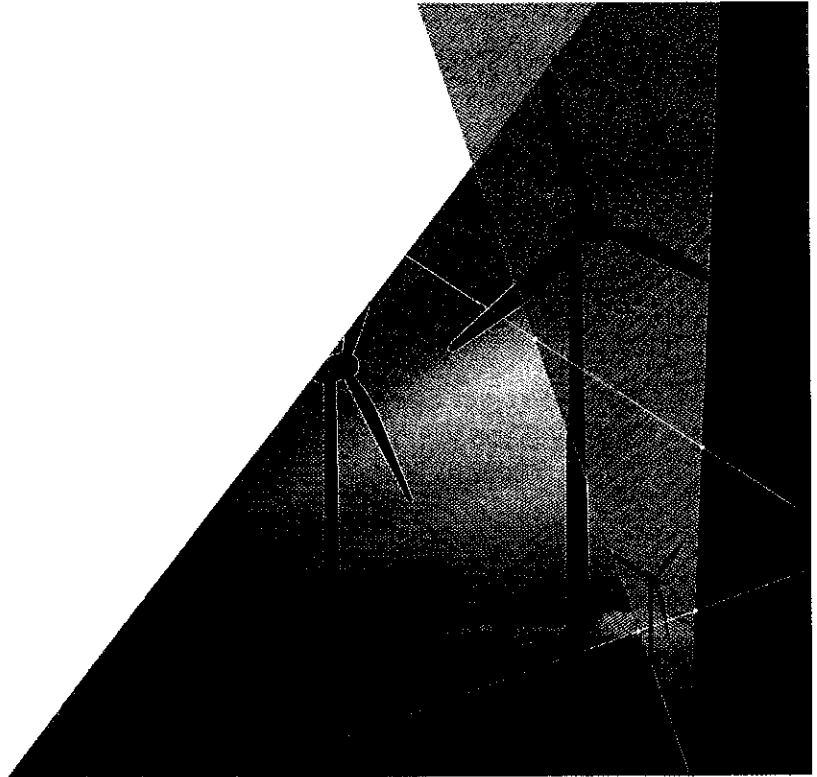

Scope Overview

- Foundation Work Package
- Sub-station
 - Jacket Transport and Installation
 - Topsides transport and installation
- Wind Turbine Generators
- Scour Protection Installation
- Rock Pad Installation
- OSP Support Operations
- Pile Oscillation Study
- OSP Topsides motions analysis

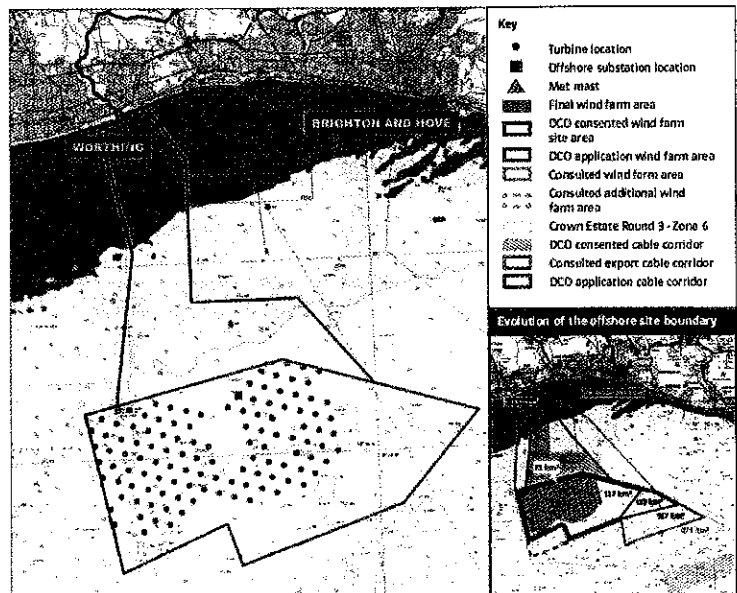



Rampion WTG Foundations

- Conventional Mono-pile up to 825te
- Carried in a transverse configuration
- Friction Restraint – verification every trip
- Two vessels operating in the field

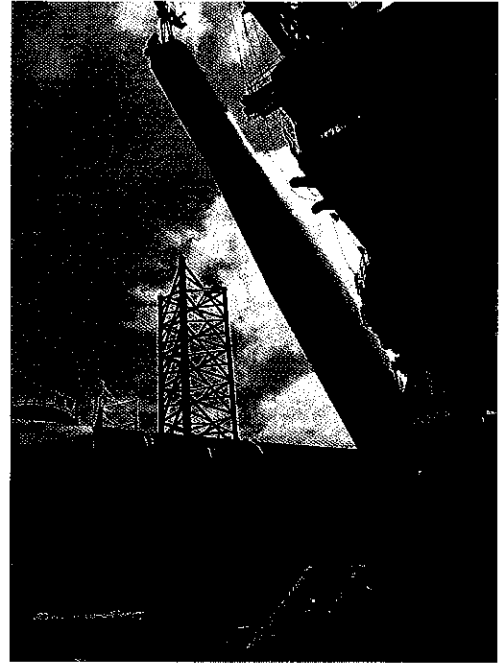

Additional Tasks on Foundation

Issues - Pile Oscillation

- Previously simplified analysis only
- Lack of understanding results in restrictive weather limits
- Dangerous

LOC/ Longitude

- Pile Oscillation Computer modelling
- Interpretation of results
- Developed working windows to improve operability and reduce WoW

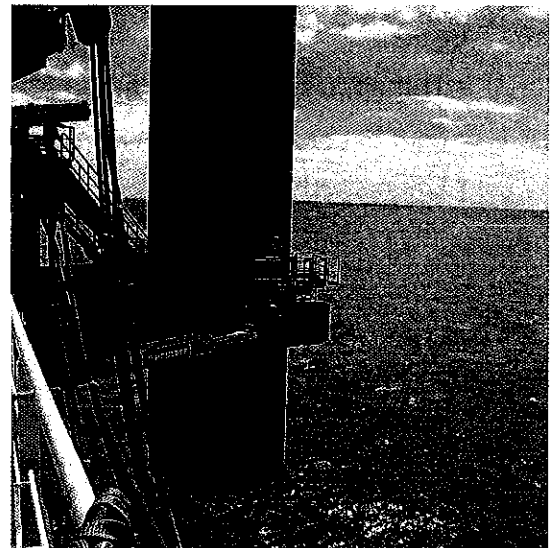



Friction Restraint

Issues

- Previously transverse piles clamped or lashed
- Physical size and design prevented securing attachments
- Sea state limited

Our Involvement

- Worked with contractor
- Developed acceptance criteria based on Guidelines
- Testing program

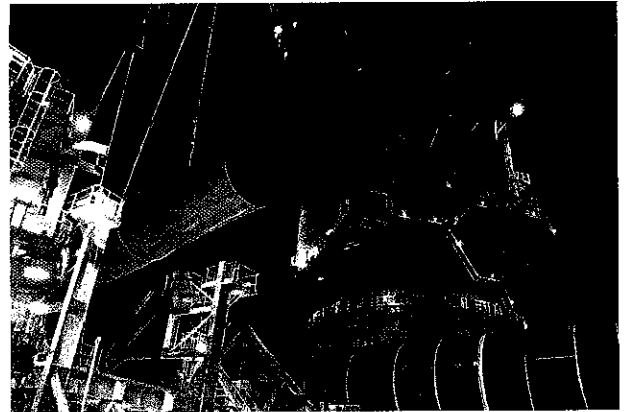

OSP Topsides

Issues

- Transportation limitations
- Sea fastening internally
- Unfinished state required additional equipment to be shipped

LOC/ Longitude Assistance

- Transportation study to determine limits
- Available on site – walk rounds and constant feed back on sea fastening
- Lashing Calc checks

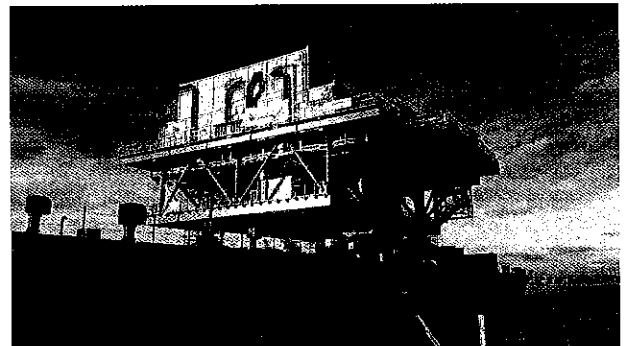



Humber Gateway OSP Installation

Novel Approach

- Modular Construction
- Drilled Piles
- Installation from Jack Up

LOC Involvement

- Early Engagement
- Clarified limitations at each stage – lifting, weather, time etc
- Developed CoA's with client / contractor program
- Flexible

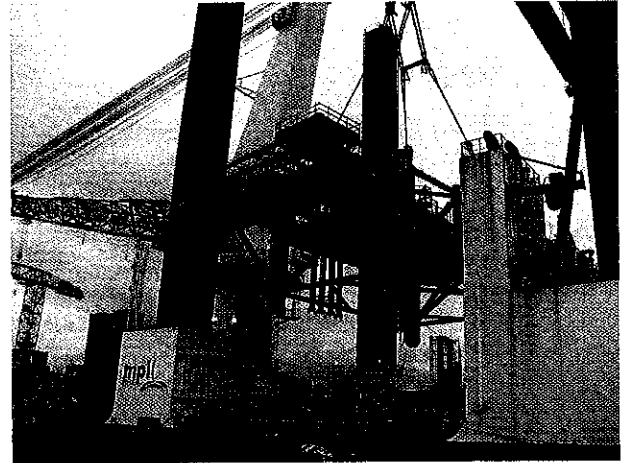

ONE PARTNER WORLDWIDE SUPPORT



Peter Croll, Project Manager
 LOC Renewables
 p.croll@loc-group.com
 www.loc-group.com



Dr RV Ahilan, Group Director
 LOC Renewables
 r.ahilan@loc-group.com
 www.loc-group.com/renewables

OIL & GAS			RENEWABLES			SHIPPING		
MARINE WARRANTY & CONSULTING								
TECHNICAL ADVISORY, DUE DILIGENCE & EXPERT WITNESS								
OWNER'S ENGINEERING & PROJECT MANAGEMENT								
TRANSPORTATION & INSTALLATION ENGINEERING								
MANAGEMENT OF MARINE CASUALTIES AND WRECK REMOVAL								
METOCEAN	NAVAL	MARINE OPERATIONS						
GEOTECHNICS	ARCHITECTURE	SUPERVISION						
ELECTRICAL	HYDRODYNAMICS	SURVEYS						
STRUCTURES	MOORINGS	INSPECTIONS						
CIVILS	MARINE & SUBSEA ENGINEERING	AUDITS						

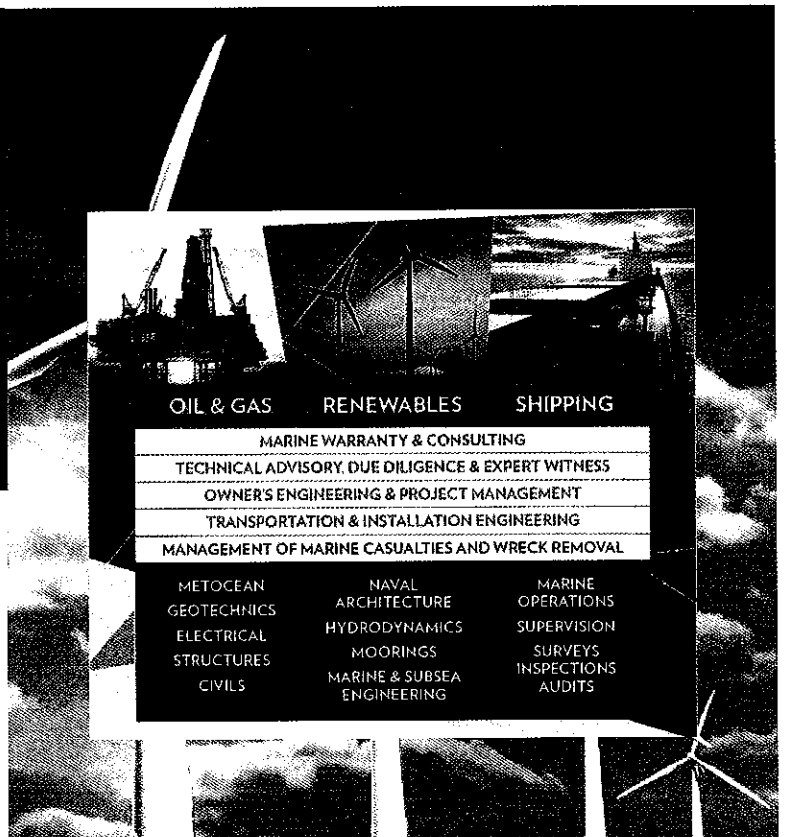

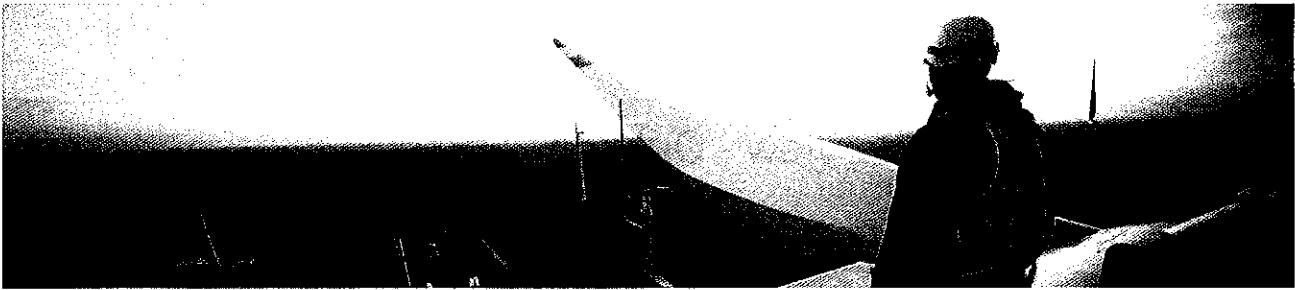

Welcome

WIND . ASSURING CONFIDENCE THROUGH COMPETENCE

Introduction DyNaLab Torben Jersch

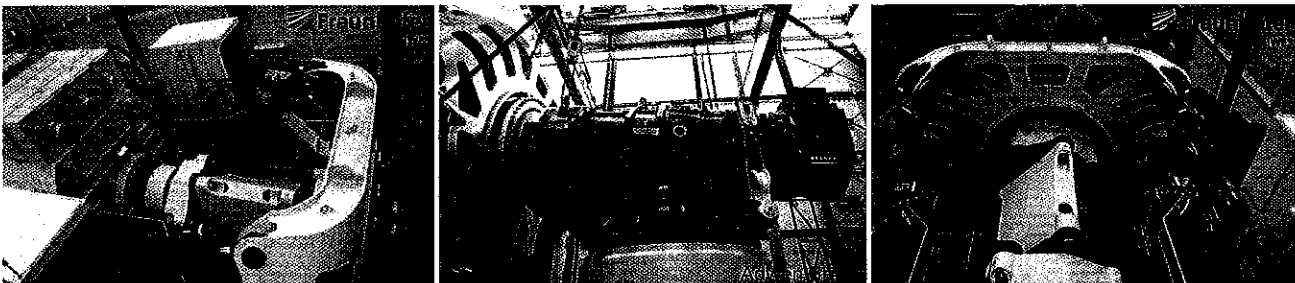

Which test can be performed at DyNaLab test bench

- > „End of Line“ Tests
- > Development Test + Optimization
- > Design Verification / Analysis / validation
- > HALT

- > Grid-Compliance-Test
- > WEC- electrical Certification-Test
- > Complete certification tests

Motor + Gearbox

Motor + Discs

Motor + Grid Compliance

Motor + Grid Compliance + IEC
WEC Class 1

Test Bench – Overview - Outside

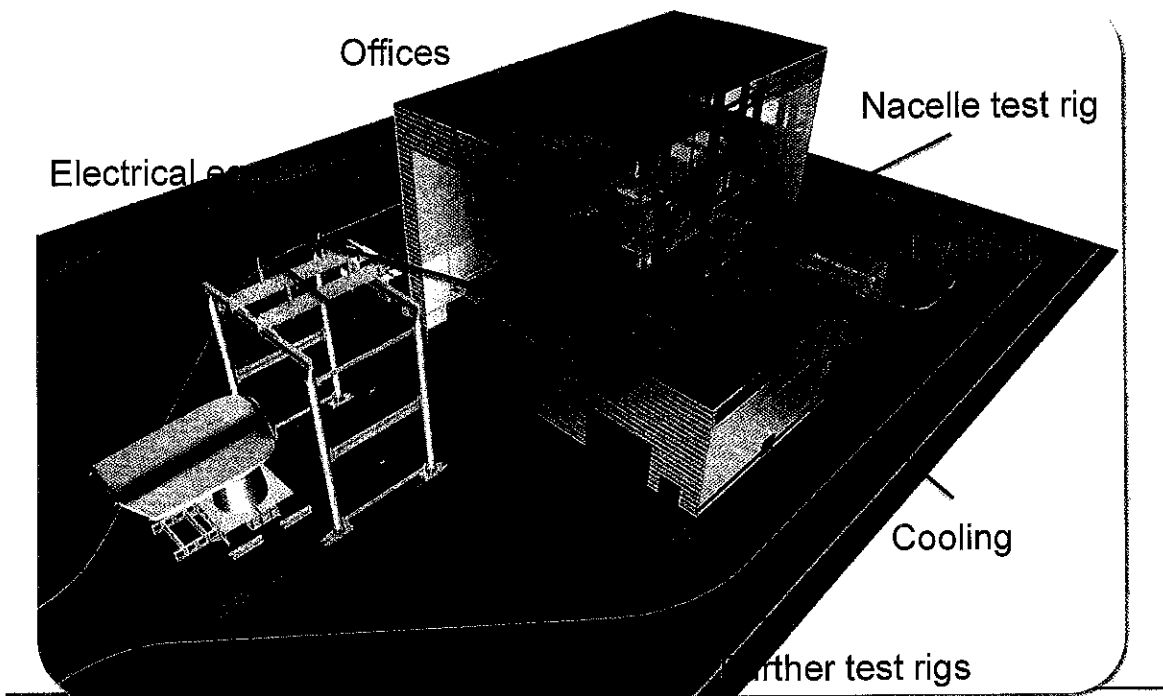

3

3/10 © Fraunhofer



Test Bench – Overview - Inside

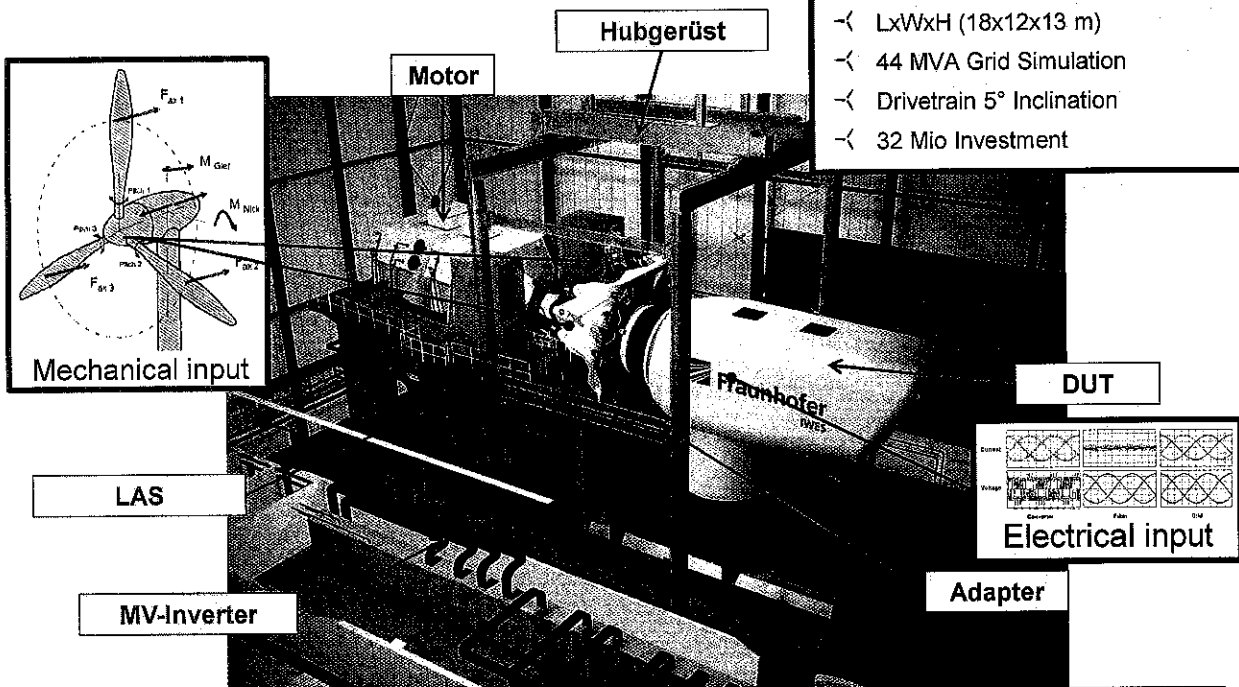

- Key point:**
- ↪ 10 MW Motor
 - ↪ Load Application system
 - ↪ DUT 2 - 8 MW (to 400 t)
 - ↪ LxWxH (18x12x13 m)
 - ↪ 44 MVA Grid Simulation
 - ↪ Drivetrain 5° Inclination
 - ↪ 32 Mio Investment

Source: IWES/IDOM

4

4/10 © Fraunhofer



Dyn. Load Application – Virtual Rotor

- < 5 DoF
- < Axial forces: ± 1900 kN
- < Bending moment: ± 20000 kNm
- < Dynamic:
to 30% max. load \rightarrow 0-2 Hz
smaller loads \rightarrow 0-3(4)Hz
- < Stat. & dyn. Weight compensation
- < Installed Hydraulic Power 1,2 MW

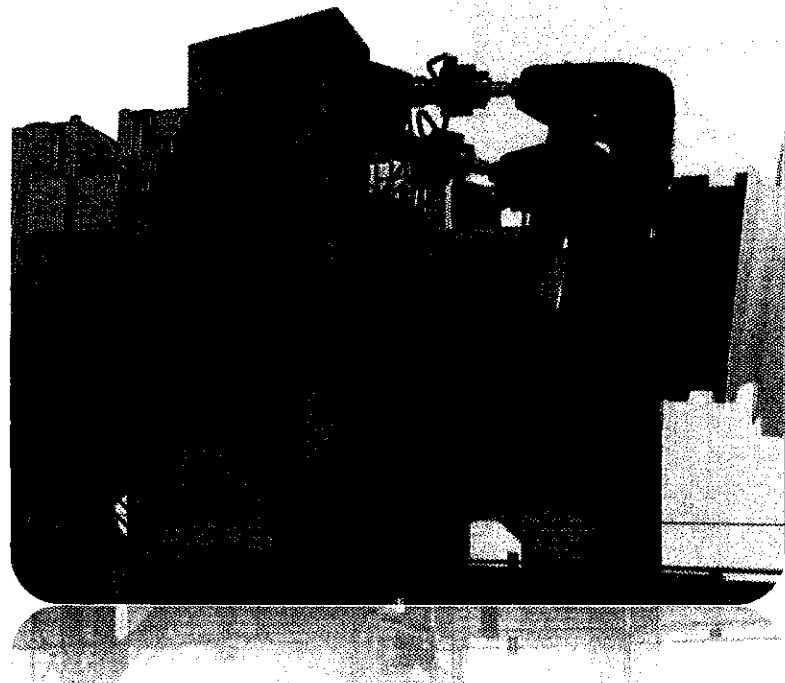

Key Point Grid Simulator

- < Nominal Voltage, Tapping for 10/20/36 kV
- < 3 independent controllable phases
- < Controllable amplitude
- < LVRT to 0%
- < HVRT 130% by additional Tapping 13/26/47 kV
- < Controllable Grid Impedance
- < Controllable phase angle
- < Frequency 45 ...55 ... 65 Hz
- < Harmonic Injection, (planned)

Example of 36 kV Tapping

Description	36 kV	33 kV
Continuous Power	15 MVA	13,54 MVA
Short Term < 3s	30 MVA	27,09 MVA
Short Term < 150ms	43,09 MVA	39,50 MVA
Inverter Limit	44 MVA	40,33 MVA
Virtual Impedance	up to 300 MVA	up to 251,5 MVA
Voltage	0 ... 130%	0 .. 142%
	0 ... 46,8 kV	0 ... 46,8 kV
Low THD, static Voltage	THD <2%	THD <2%
Medium THD, Dynamic Voltage	THD <5%	THD <5%

Grid Compliance Testing - Voltage Sags

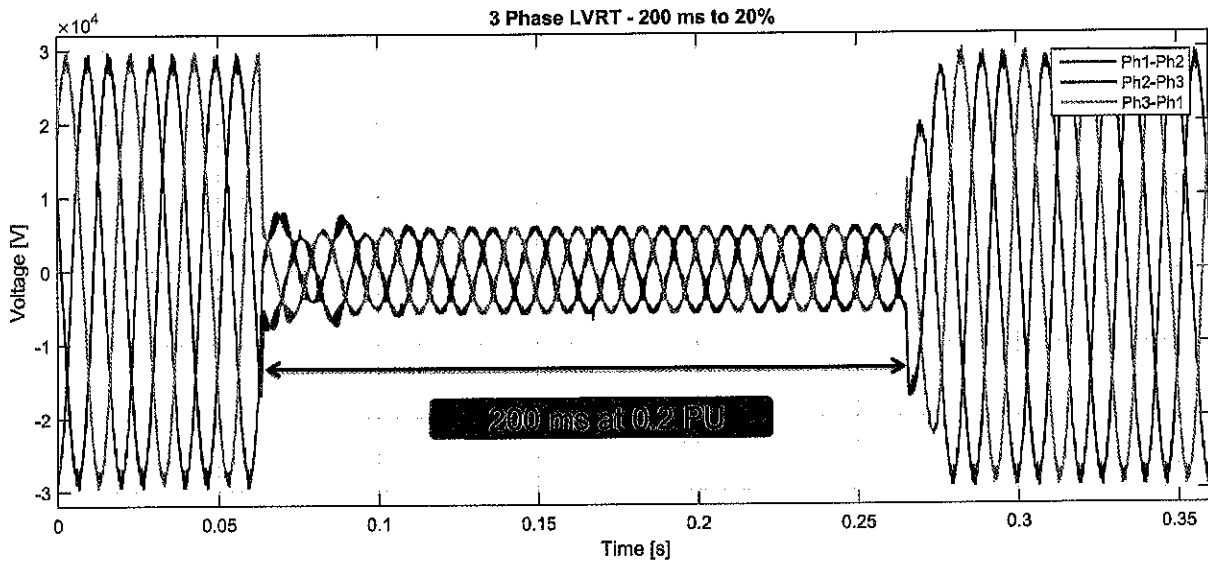

Grid Compliance Testing - Voltage Sags

Independent control of each phase

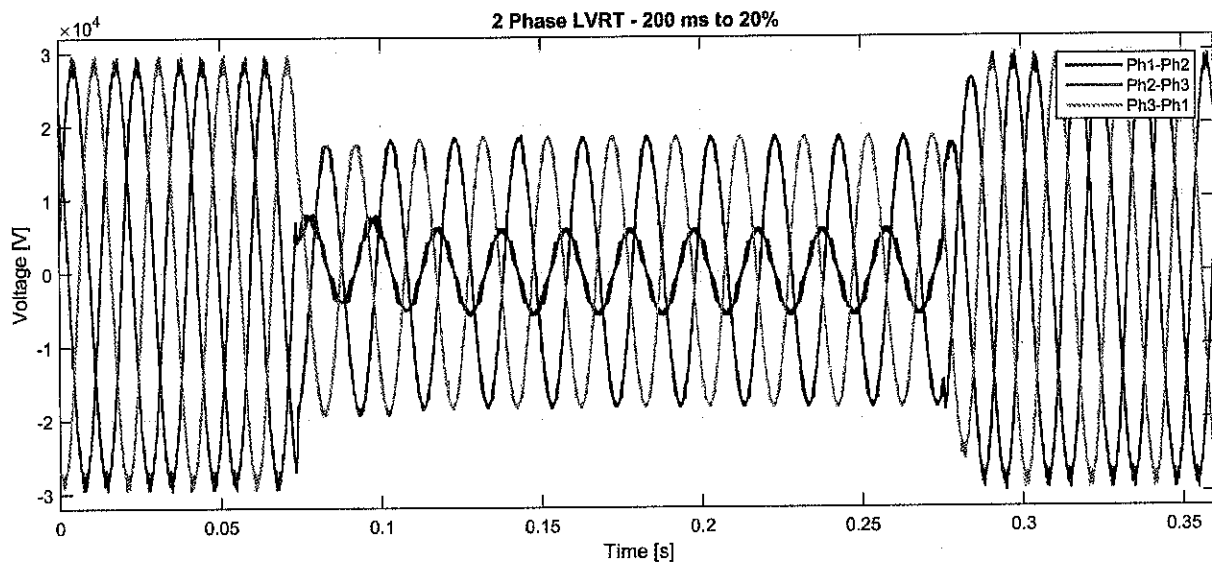

Further Test Benches

- < BeBenXXL - In Operation (Suzlon)
- < Pitch Bearing Test Benches - in Operation (Senvion)
- < HAPT – Pitch Bearing Test Benches - in Construction Phase(Hamburg)
- < Hil-Grid-Cop - in design Phase (Senvion, Nordex, Vestas)

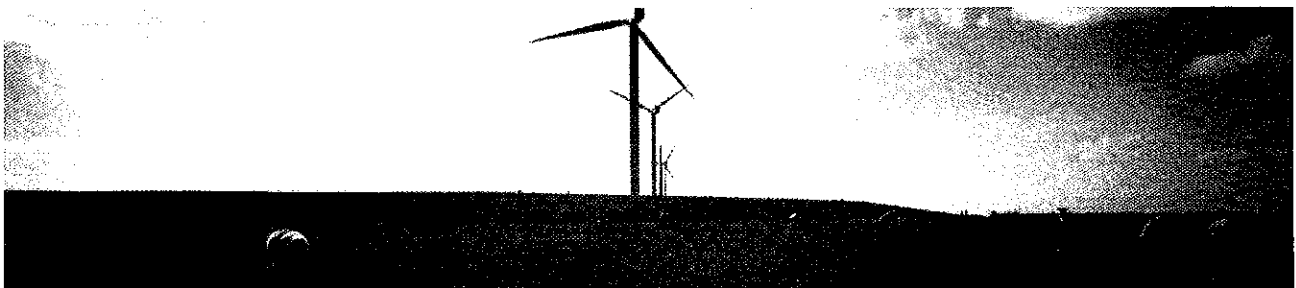

Thank you.

Questions?

Torben.Jersch@iwes.fraunhofer.de

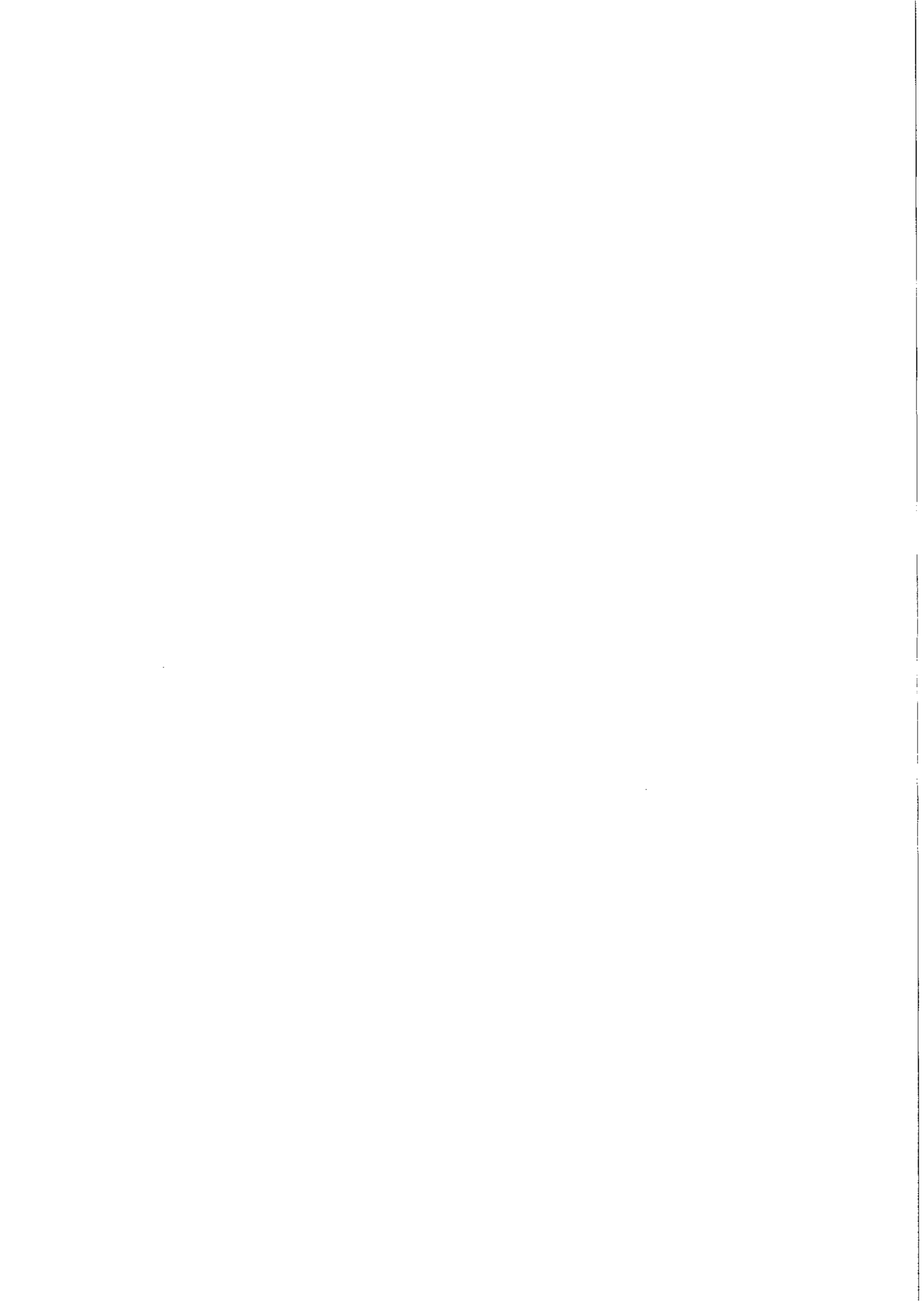

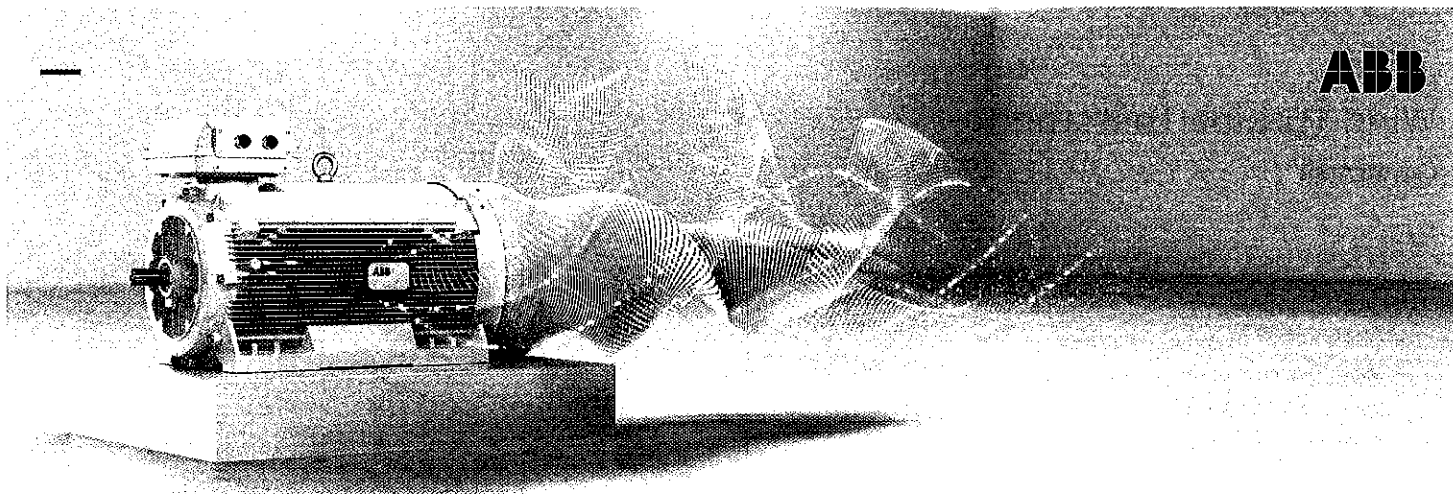

7TH SEPTEMBER 2017

ABB Medium Voltage Drives

Solutions for Teststand Applications

Kai Pietiläinen, Special Applications Manager

Content

ABB MV Drives

- Introduction

Main Driver

- ACS6000
- Wind turbine test stand
- Examples
- Motor

Wind Turbine Teststand Generator

Component Testing

Features

- DUT could be motor or generator
- Multidrive configuration
- Very low THDv out (DOL motor test)
- Asynch & Synch motors - parametrization
- High speed (frequency) requirements

Prototype testing facility

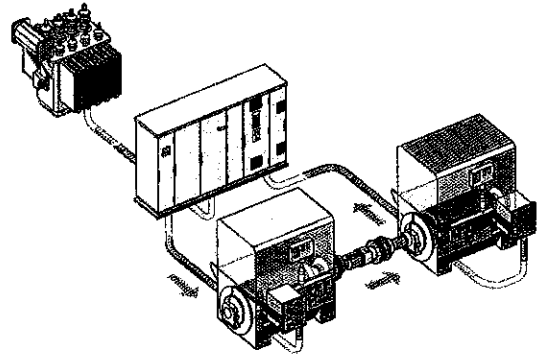

Wind Turbine Teststand Gearbox

Component Testing

Features

- Multi motor configuration usually required (power regeneration on the DC bus)
- Depending on the complexity of the gearbox, more than 2 motors can be needed
- Dynamic load & speed profile (e.g. to simulate the gust of wind)

Prototype testing facility

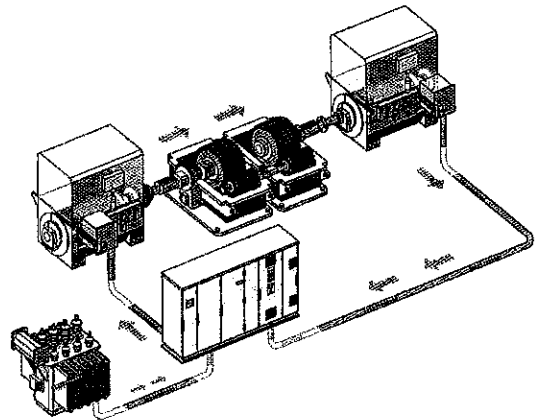

Wind Turbine Teststand

Nacelle

System Testing

Features

- DUT could be the entire nacelle or single components (gearboxes, generators)
- Direct drive (low freq, ca 8-10 rpm) or gearbox

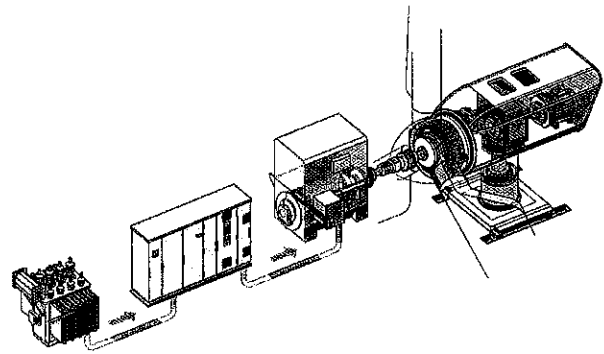

Prototype testing facility

Wind Turbine Test Stand

Grid Simulator and Main Driver

Scope

- Input transformer
- ACS6000 Multi-drive
 - 12 MW
 - 8 rpm
 - 33 kV grid-simulator
- Output Transformer
- Main driver Synchronous motor

Common Voltages Taiwan
10kV/11.4kV/13.8kV/26kV

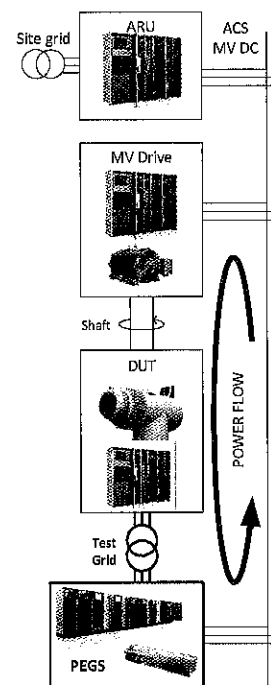

Single Line

One 8 MW Main Driver

Main Drive train:

- Synchronous motor
- Power: 12 MW @ 8rpm
- Speedrange: 0-25 rpm

Gridsimulator

- SCC capability: 44 MVA
- Voltage: 33 kV
- World wide grid code capability
- HVRT
- LVRT
- Single phase LVRT
- Single phase HVRT
- Grid impedance emulation
- Harmonic injection

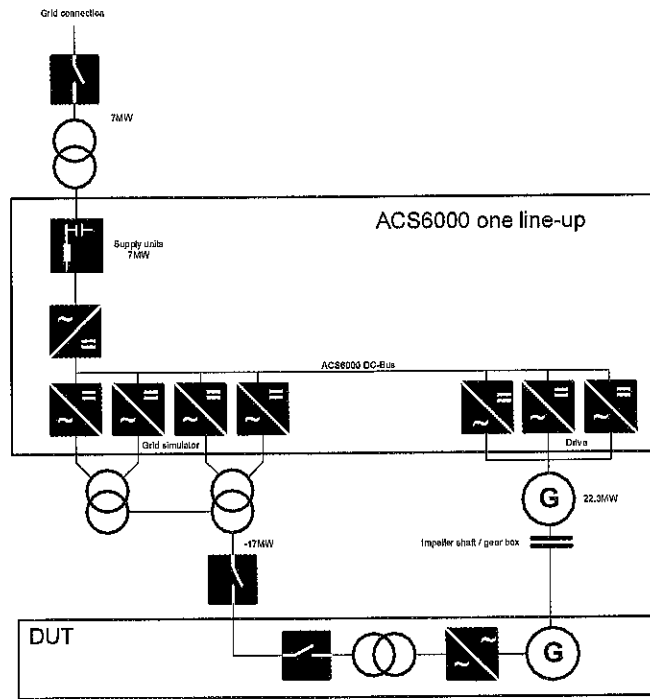

Wind Turbine Teststand Nacelle

Main Driver Motor

Features

- Synchronous Motor
 - Single motor for 12 MW @ 8 rpm
 - Speed range up to 25 rpm
- Simplification of the mechanical setup
- Easy protection of the motor
- Straight forward control in a wide speed range
- Easy assembly at site
- Easy maintenance
- Highest efficiency
- Mature Technology

Prototype testing facility

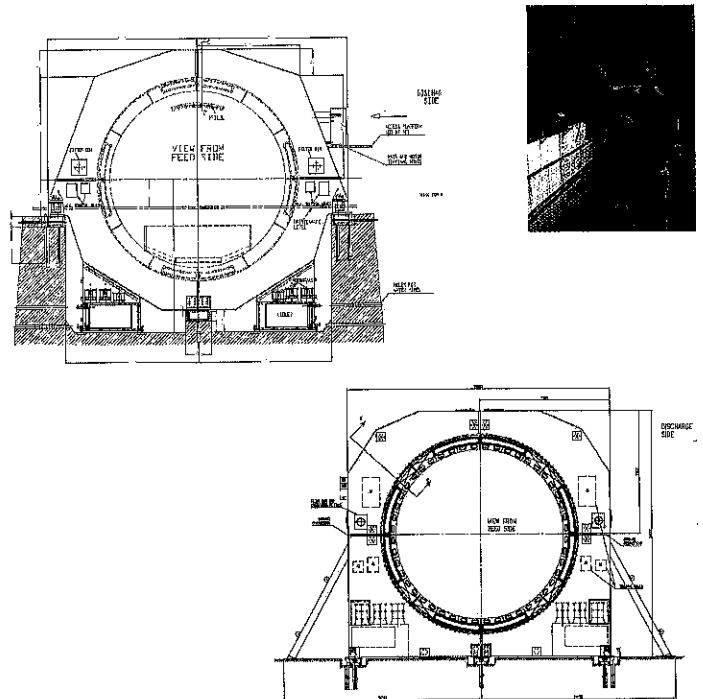

Single Line

Tandem motor 12 MW Main Driver

Main Drive train:

- Synchronous motor
- Power: 12 MW @ 8rpm
- Speedrange: 0-25 rpm

Gridsimulator

- SCC capability: 44 MVA
- Voltage: 33 kV
- World wide grid code capability
- HVRT
- LVRT
- Single phase LVRT
- Single phase HVRT
- Grid impedance emulation
- Harmonic injection

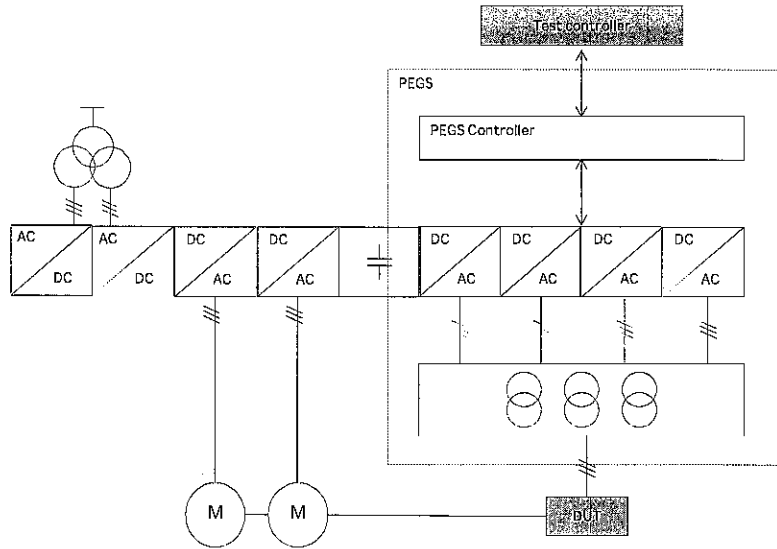

Wind Turbine Teststand

Nacelle

Main Driver Motor

Features

- Synchronous Motor
 - Tandem closed coupled motors for 12 MW @ 8 rpm
 - Speed range up to 25 rpm
- Simplification of the mechanical setup
- Easy protection of the motor
- Straight forward control in a wide speed range
- Easy assembly at site
- Easy maintenance
- High efficiency
- Mature Technology

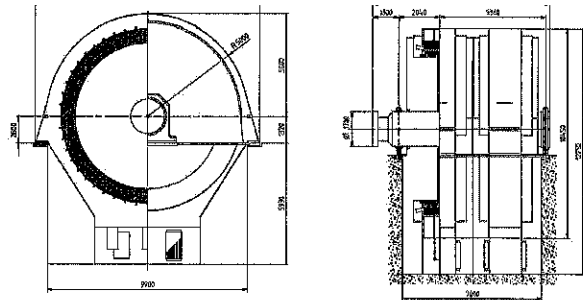

Main Data

Number of motors	1
Type	Sv 805 / 48 - 2D5
Rated motor output on shaft	12,0 MW
Rated power factor	1,000
Rated current	2x 1250,9 A
Maximum continuous overload	13,0 MW
Rated voltage	3,000 kV
Range of voltage variation	0,96 pu / 1,05 pu
Maximum installation height	100,0 m
Rated frequency	3,2 - 10 Hz
Rated speed	8,00 - 25 rpm
Runaway speed	30,00 rpm
Material of insulation (VSI)	3630
Permissible unbalanced load (negative sequence current system) related to rated current	0,080 pu

Insulation Class

ACS6000

Outline, ACM6113_F12_2s9_4a9_1V3_C38_C37_W3a_W3a

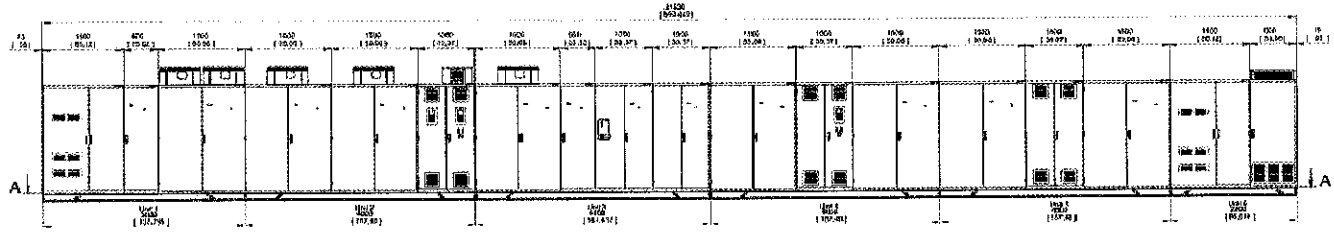

Cut A-A (without base frame)

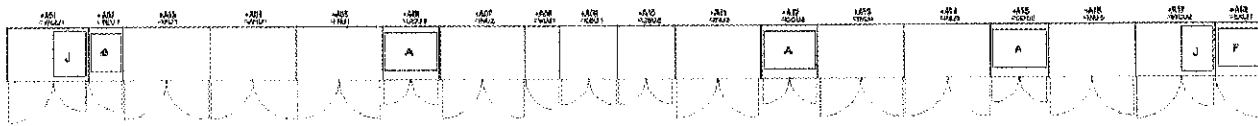

Single Phase LV Ride Through

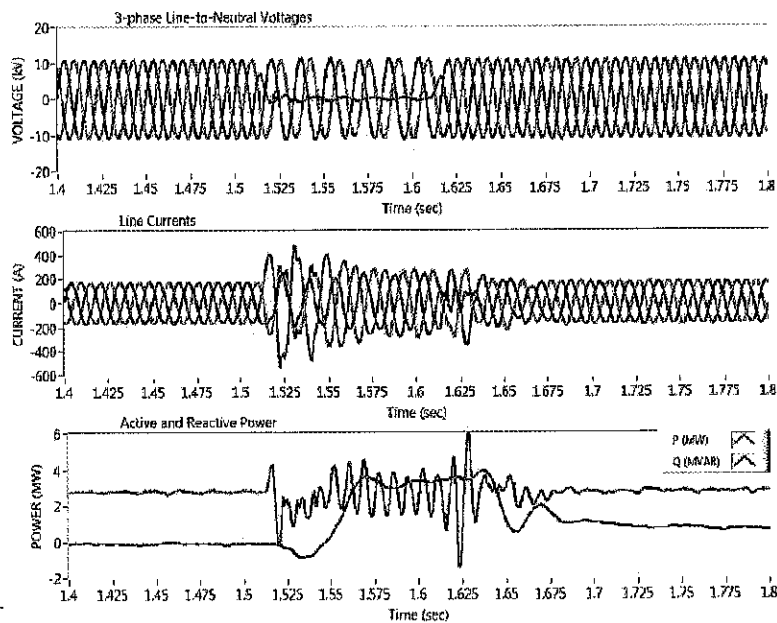

3 Phase LV Ride Through

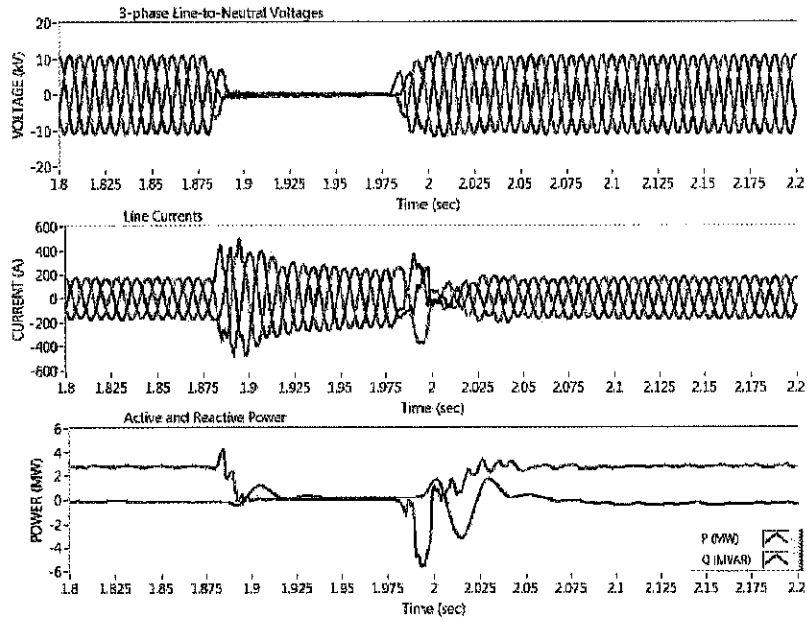

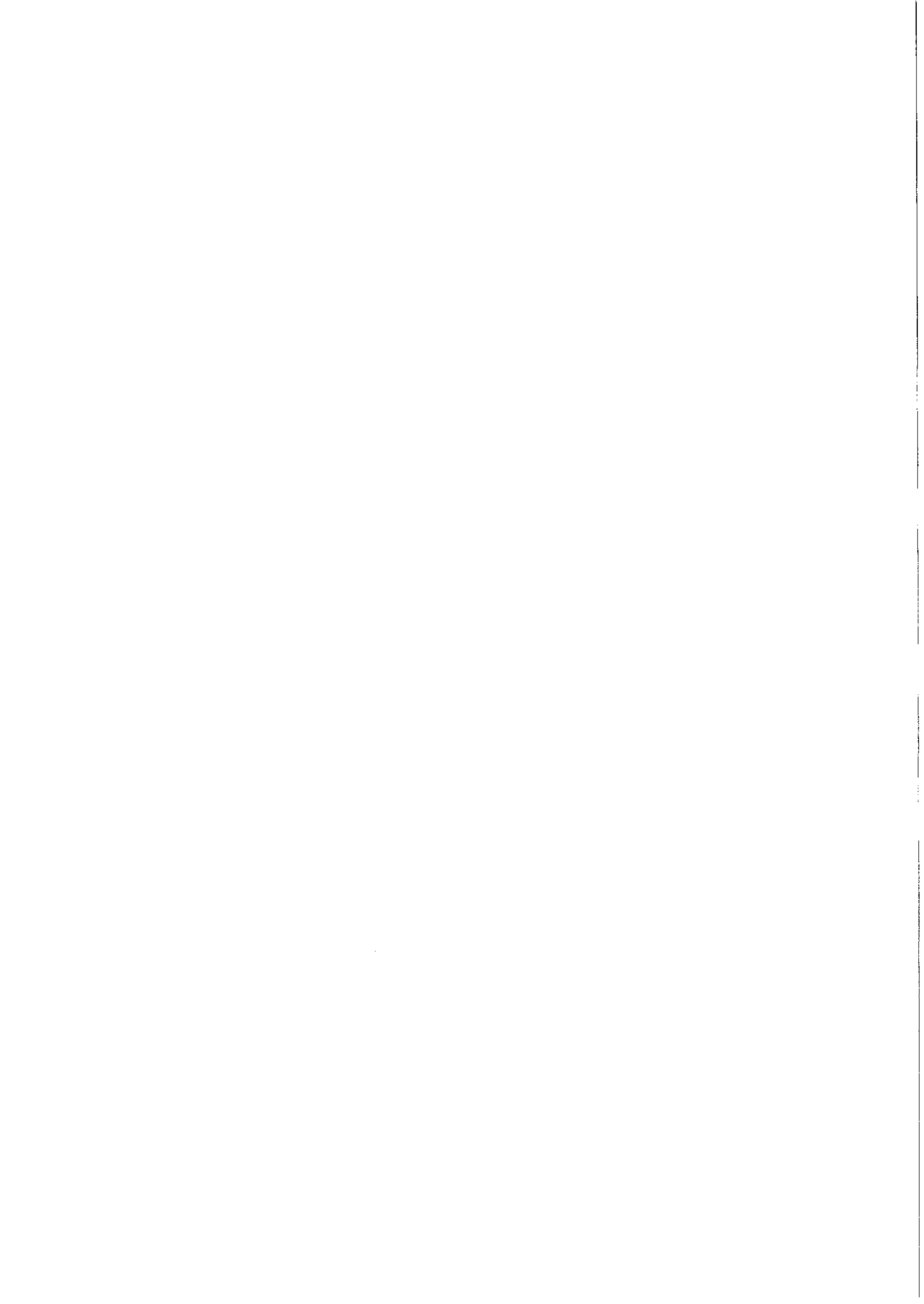

Offshore Windfarms - Licensing Procedure

Visit of the Delegation of Bureau of Standards, Metrology and Inspection (BSMI), Ministry of Economic Affairs (MOEA), Taiwan



Dr. Nico Nolte

German Exclusive Economic Zone

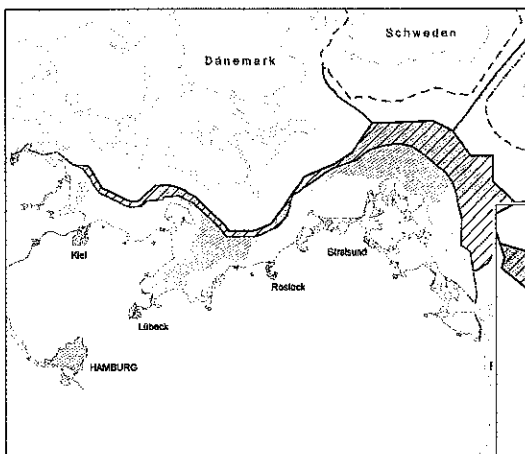

Baltic Sea:
4.500 km²

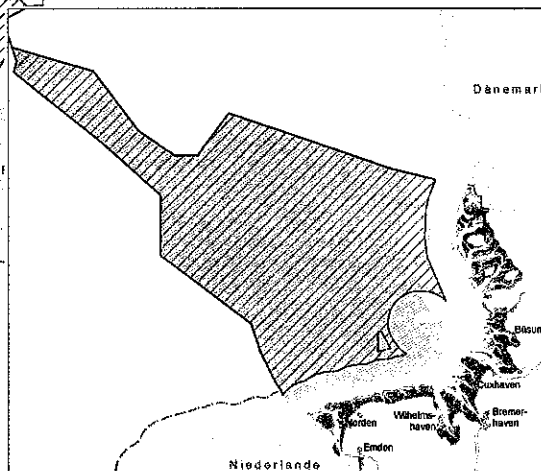

North Sea:
28.600 km²

Political framework

- Target in Germany: 15,000 MW offshore windenergy by 2030 in the EEZ and the territorial sea
- Renewable Energy Act: 40-45 % of the electricity supply must be generated from renewable energy by 2025; 55-60 % by 2035; 80% by 2050

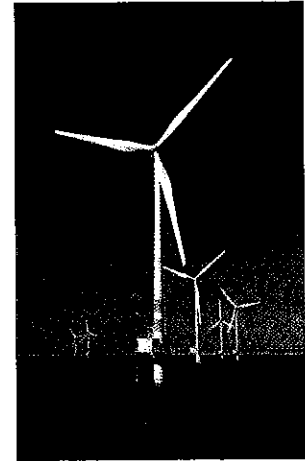

Wind farms in the North Sea

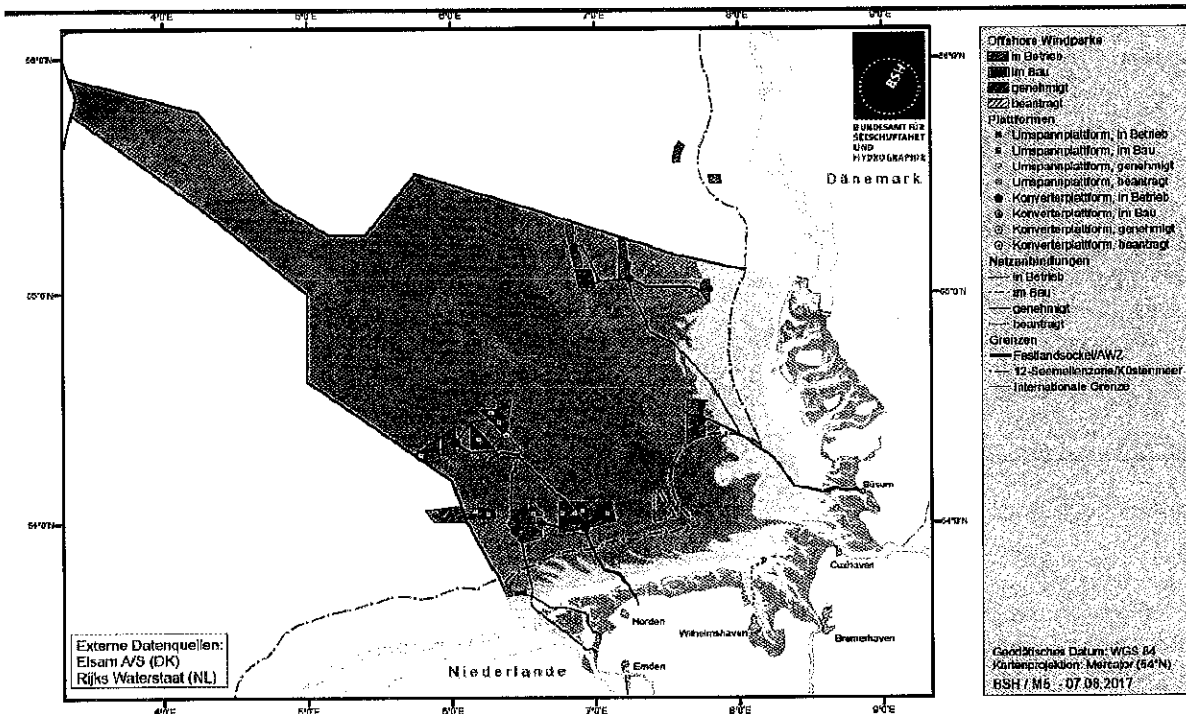

Wind farms in the Baltic Sea



BUNDESAMT FÜR
SEESCHIFFFAHRT
UND
HYDROGRAPHIE

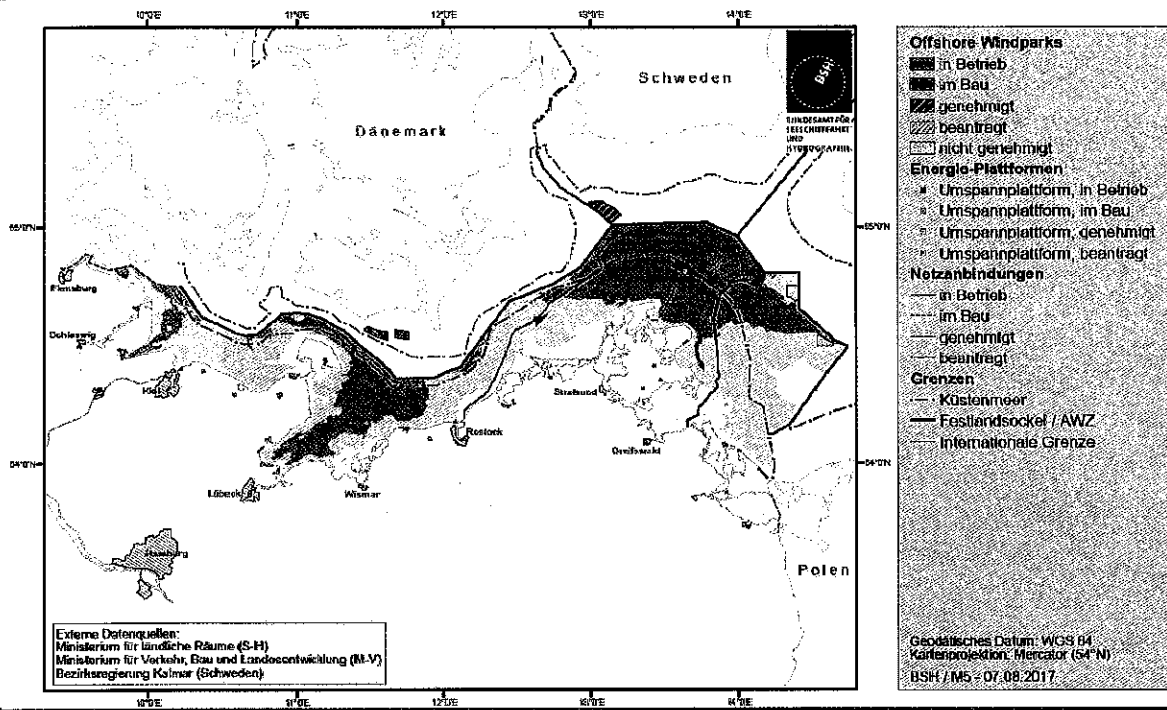

5

State of Development



BUNDESAMT FÜR
SEESCHIFFFAHRT
UND
HYDROGRAPHIE

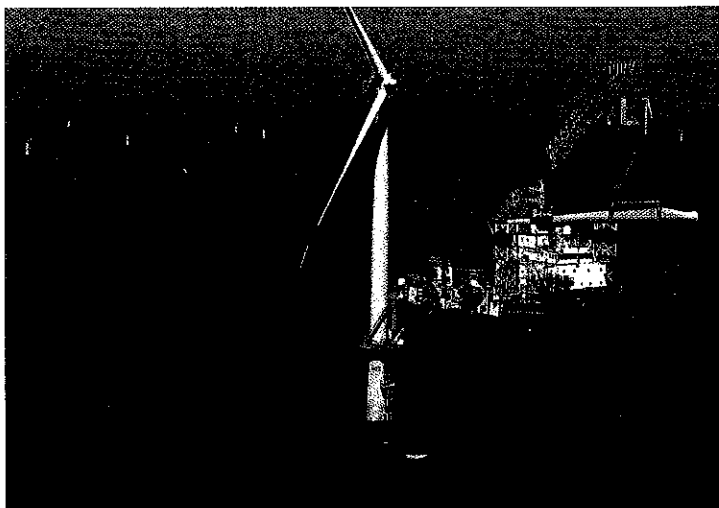

Offshore wind farms

- 34 approvals
(2062 turbines)
- 5 projects under
construction
- 14 projects
operating
- 1015 turbines
with 4.600 MW on the grid
- 7 converter platforms built

6

HelWin alpha & HelWin beta



BUNDESAMT FÜR
SEESCHIFFFAHRT
UND
HYDROGRAPHIE



Quelle: Bundespolizeidirektion Bad Bramstedt | Direktionsbereich Bundespolizei See

7

Wind Energy at Sea Act (WindSeeG)



BUNDESAMT FÜR
SEESCHIFFFAHRT
UND
HYDROGRAPHIE

Planning Approval required

A plan may be only approved if there is:

- no threat to the marine environment
- no threat to safety or efficiency of shipping traffic
- no threat to national or allied defence
- other public law requirements (such as Maritime Spatial Plan)

Positive:

- concentrating effect, no other public law licenses are necessary (all licenses are concentrated within one license)
- balancing of interests (fishery, sand and gravel....)

8

- Environmental Impact Study
- Design Basis (according to Standard „Design of OWT“)
- Preliminary Draft of Installation Structure (according to Standard „Design of OWT“)
- Technical Risk Analysis
probability of a ship/wind turbine-collision
- Prognosis on the hull-retaining configuration of the substructure of the foundations

Standard Investigation of the Impacts of Offshore Wind Turbines on the Marine Environment (StUK)

- 4th edition of Oktober 2013
- Requirements for the Environmental Impact Study and monitoring during construction and operation

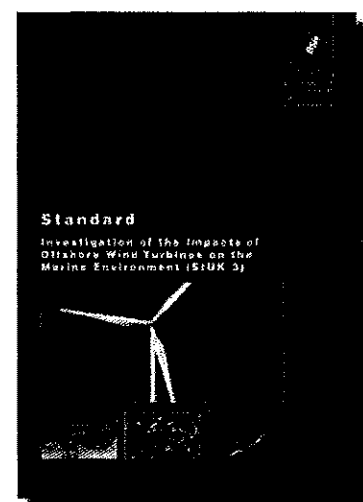

<http://www.bsh.de/en/Products/Books/Standard/index.jsp>

Assessment of marine environment

intensive investigations of the features of the project area in the sea before approval

Monitoring program (several years) during construction and operation

investigated subjects:

- Benthos
- Fish
- Birds (resting birds, migratory birds)
- Marine mammals (harbour porpoise, seals)
- natural scenery
- cultural assets

Noise reduction during construction

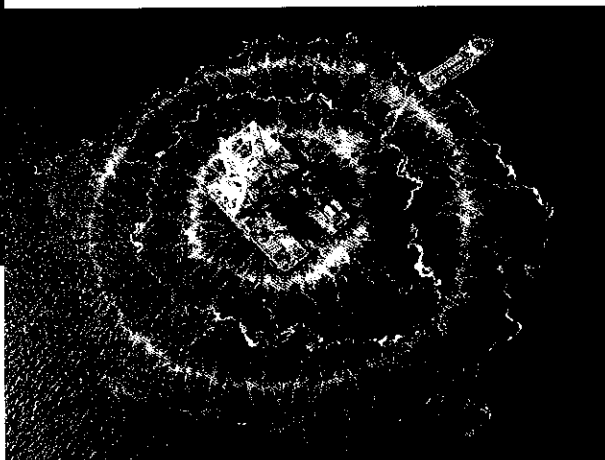
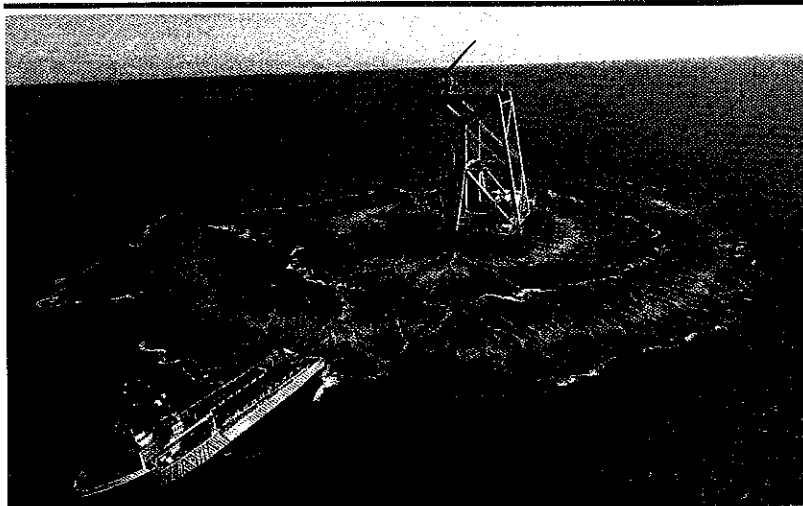

Standard Contents of an Approval

- requirements for safe construction
- use of environmentally friendly substances, non-reflecting coating
- requirement for “collision-friendly” foundations
- requirement for noise mitigation measures
- requirements regarding the equipment (including nautical lights and AIS)
- duty to decommission and financial security for safeguarding the costs of decommissioning

13

BSH Standards

Standard Ground Investigations for Offshore Wind Farms

- update February 2014
- geotechnical and geophysical requirements

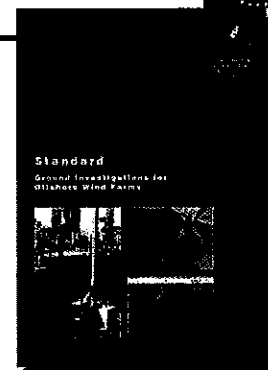

Standard Design of Offshore Wind Turbines

- update July 2015
- Requirements for the construction and certification of constructional components of an offshore windfarm

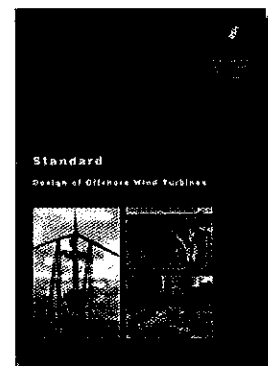

14

alpha ventus & FINO1



BUNDESAMT FÜR
SEESCHIFFFAHRT
UND
HYDROGRAPHIE

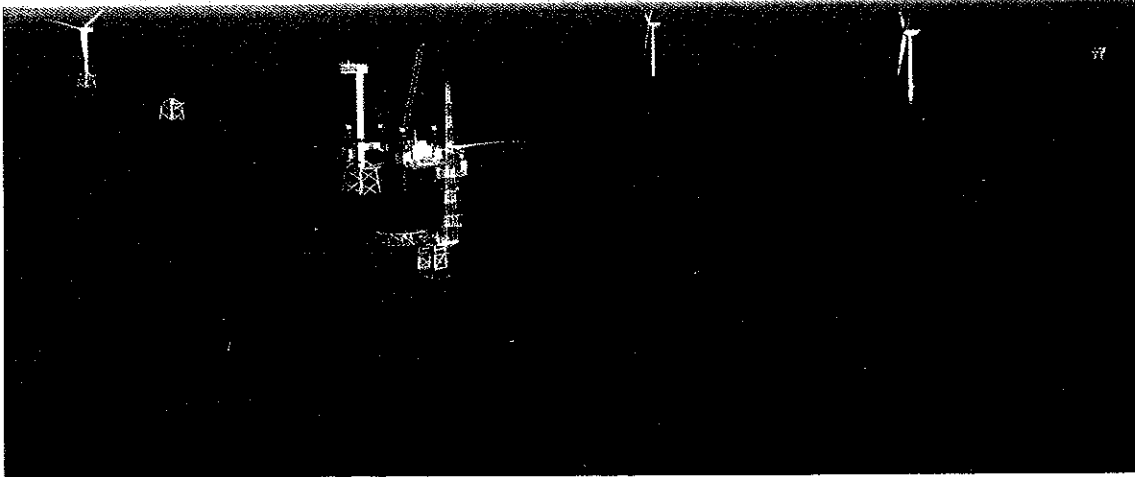

15

Bard Offshore 1



BUNDESAMT FÜR
SEESCHIFFFAHRT
UND
HYDROGRAPHIE

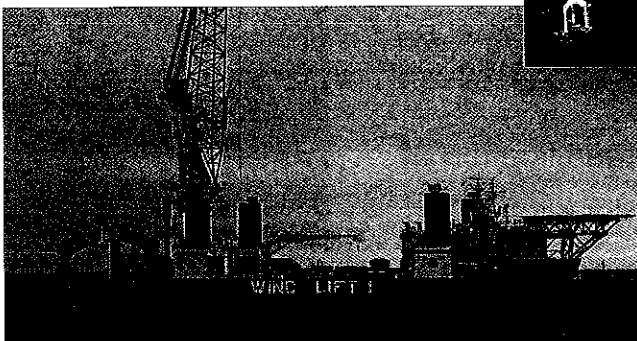
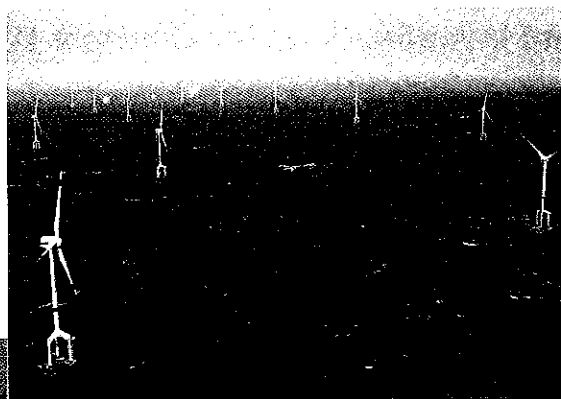

16

Thank you!



BUNDESAMT FÜR
SEESCHIFFFAHRT
UND
HYDROGRAPHIE



17

North Sea – EEZ: Maritime spatial plan



BUNDESAMT FÜR
SEESCHIFFFAHRT
UND
HYDROGRAPHIE

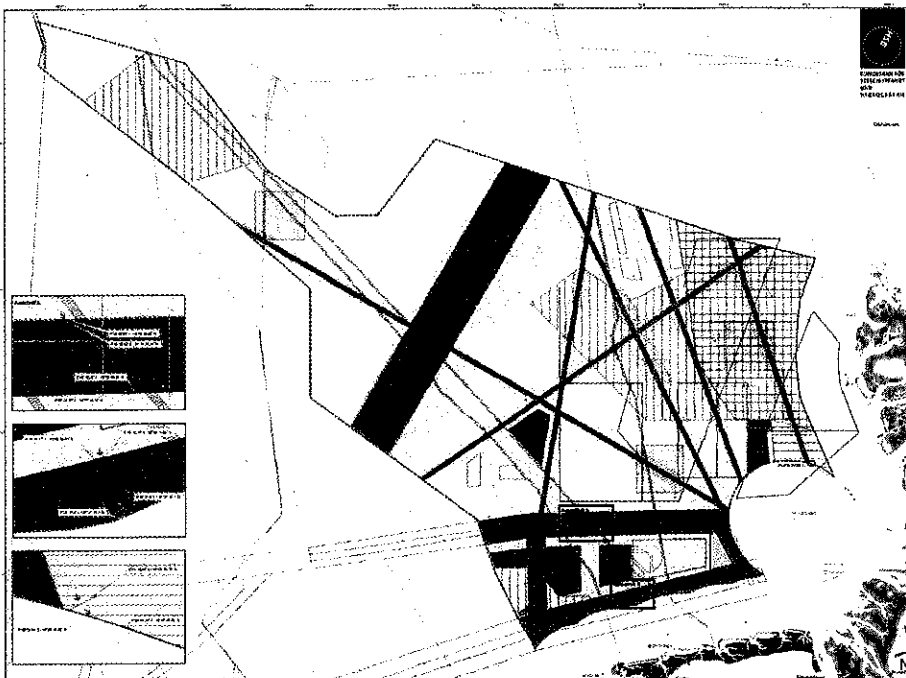

- priority areas for shipping, pipelines and offshore wind energy (i.e. must be kept free from obstacles)
- reservation areas (i.e. shipping has special weight in balancing process)
- no wind turbines in Natura 2000 areas
- targets and planning principles
- clarity for investors and stakeholders

18

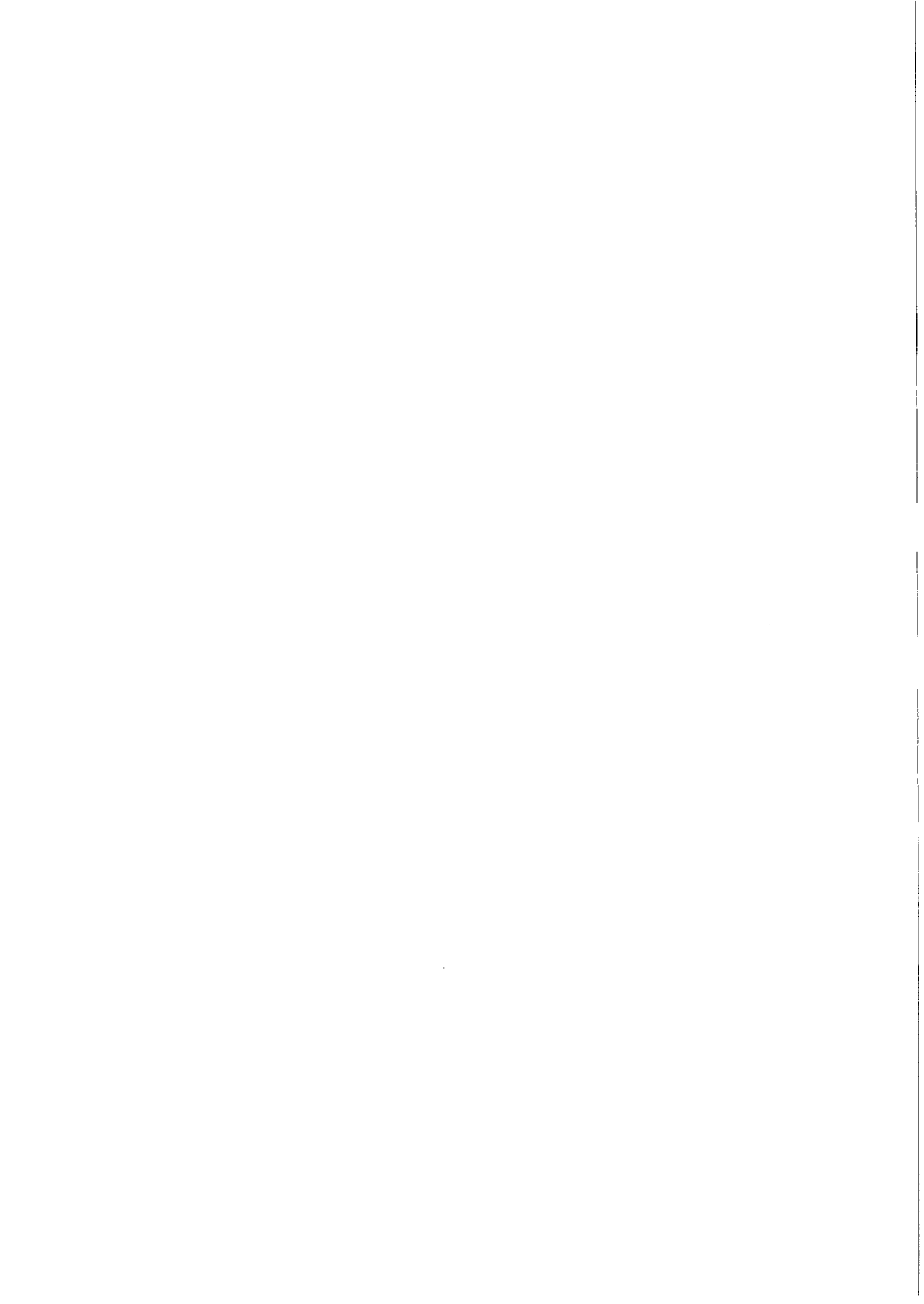

ENERGY

Risk Management in Offshore Wind and Certification

Offshore experience matters

Why are offshore wind projects complex?

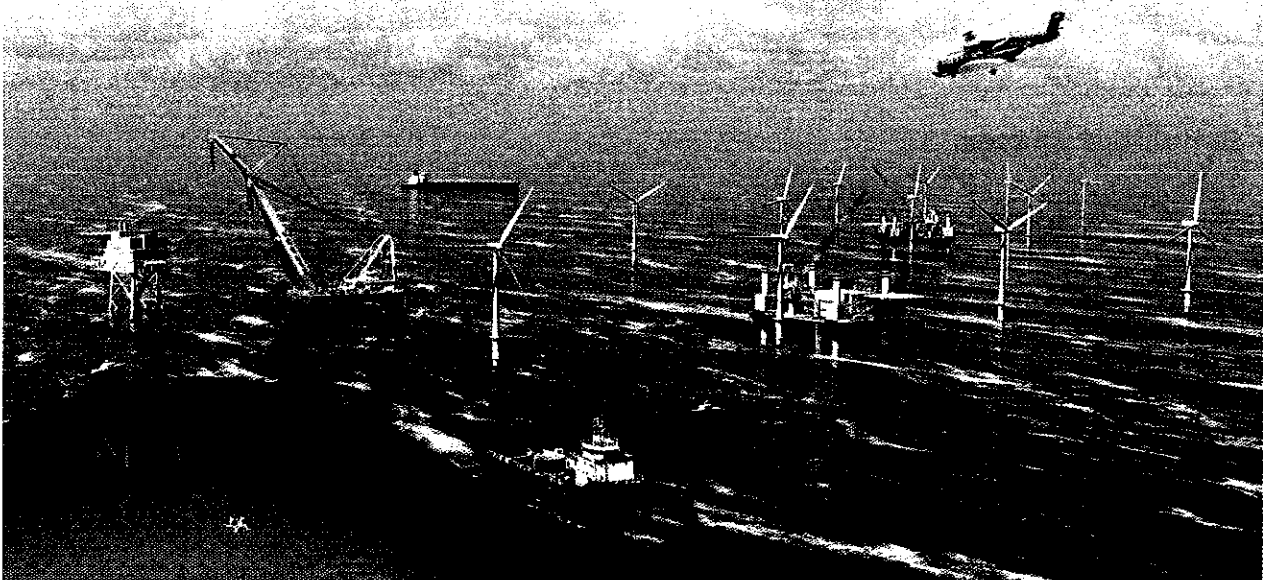

Independent expertise by a third party - EXPERIENCES

extract of references

Lessons learned from more than 60 offshore wind projects

- London Array
- LINCS
- Thanet
- Walney I & II
- Greater Gabbard
- Barrow
- Kentish Flats
- Burbo
- Lynn & Inner Dowsing
- Rhyl Flats
- Robin Rigg
- Teeside
- Gunfleet Sands I, II, III
- West of Duddon
- Thornton Banks
- Egmond aan Zee
- Horns Rev II
- BARD Offshore I
- MeerWind
- Nördlicher Grund
- Innogy I
- Nordsee Ost
- Alpha Ventus
- Baltic I
- Baltic II
- Wikinger
- GodeWind I + II
- Borkum Riffgrund
- Sandbank
- Albatros
- Northwind
- ...

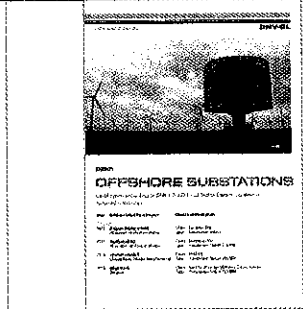
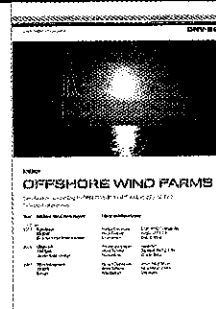
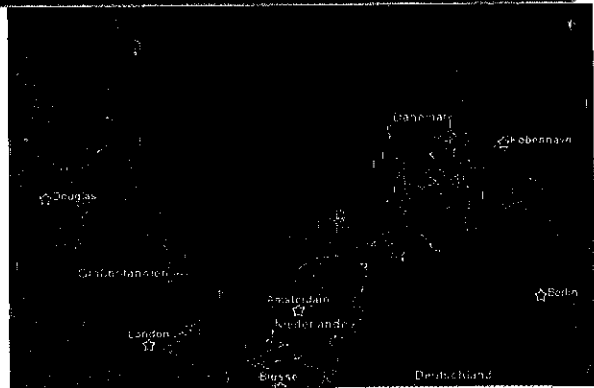

Power plant project and certification - PHASES

Project phases



Simplified phases

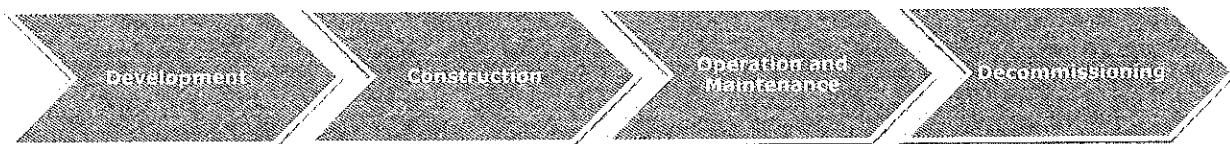

Certification phases



Wind power plant - ASSETS

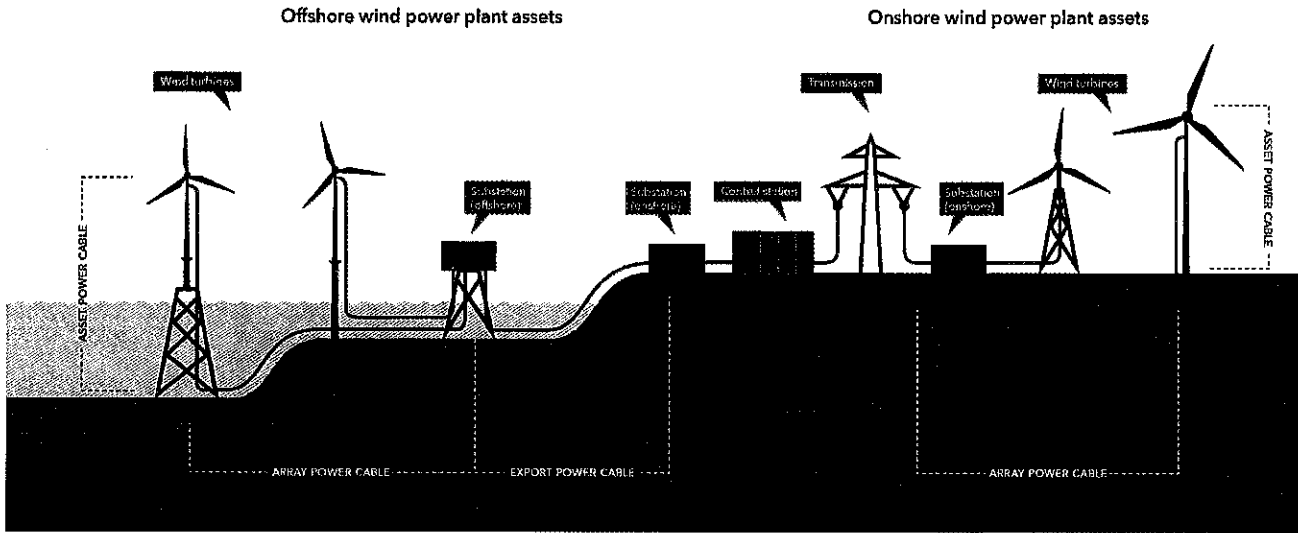

Project certification scheme DNVGL-SE-0190

Assets	Certification phases						Project phases				Click to section	
	Design	Design	Design	Design	Design	Design	Construction	Commissioning	Operation	Maintenance	Decommissioning	
Wind power plant life-cycle phase [1.6.1]	[2.2]	[2.3]	[2.4]	[3.2]	[3.3]	[4.2] Commissioning, [4.3] Operation, [4.4] Maintenance	[4.5]	Sec.5	Sec.6	Sec.7		
Wind power plant assets	[2.2]	[2.3]	[2.4]	[3.2]	[3.3]	[4.2] Commissioning, [4.3] Operation, [4.4] Maintenance	[4.5]	Sec.5	Sec.6	Sec.7		
Wind turbines [1.4]	[2.2]	[2.3.3]	[2.4.3]	[3.2.2]	[3.3.2]	[4.2.3], [4.3.3], [4.4.3]	[4.5.2]	[5.2]	Sec.6	[7.1]		
Substation [1.4]	[2.2]	[2.3.4]	[2.4.3]	[3.2.3]	[3.3.3]	[4.2.3], [4.3.3], [4.4.4]	[4.5.3]	[5.3]	Sec.6	[7.2]		
Power cables [1.4]	[2.2]	[2.3.5]	[2.4.4]	[3.2.4]	[3.3.4]	[4.2.4], [4.3.4], [4.4.5]	[4.5.4]	[5.4]	Sec.6	[7.3]		
Control station [1.4]	[2.2]	[2.3.6]	[2.4.5]	[3.2.5]	[3.3.5]	[4.2.5], [4.3.5], [4.4.6]	[4.5.5]	Sec.5	Sec.6	Sec.7		

Concept



- Plausibility check of the wind power plant concept
- Demonstrating a feasible concept of the wind power project

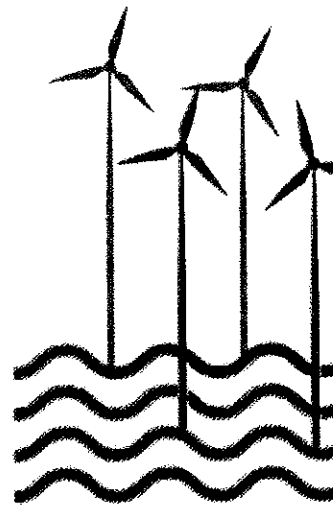

Design basis



- Design basis covers the site conditions and the basis for design and subsequent phases.
- Demonstrating that a feasible and compliant catalogue of applicable standards and methods is prepared and site conditions are clarified.

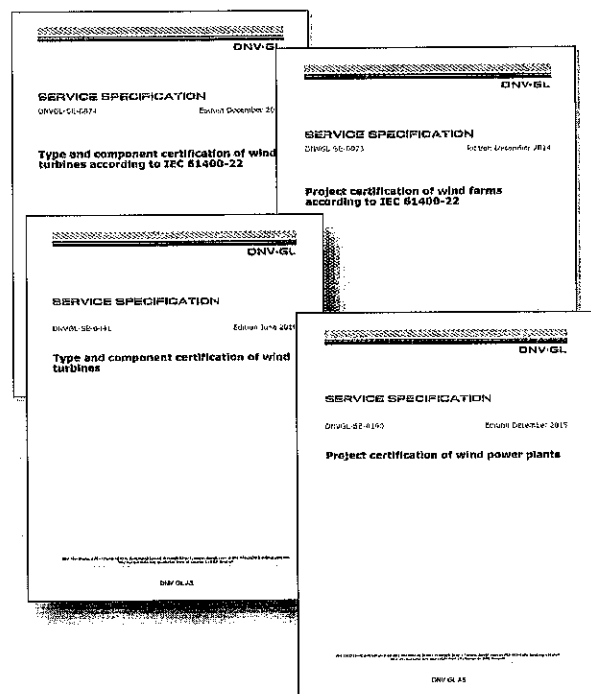

Site-specific Design



Wind Turbine

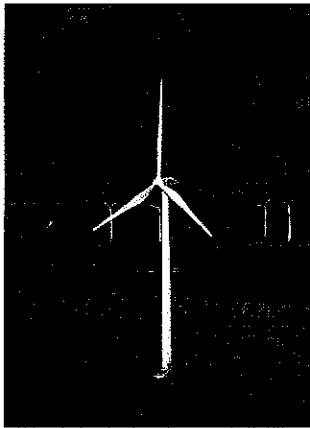

Turbine Class

Wind Farm Site

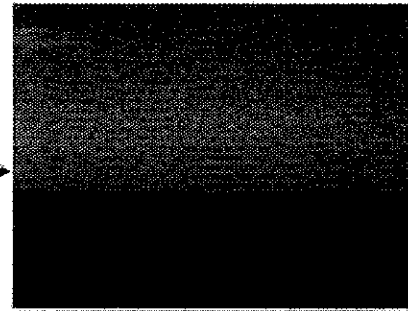

Site Conditions

Do they match???

Manufacturing surveillance



- Manufacturing covers the surveillance during manufacturing of the project related assets.

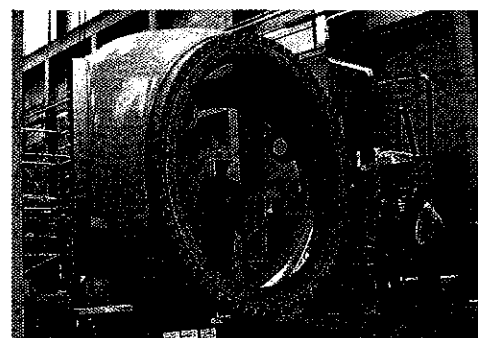

- Demonstrating that the manufacturing of key components is in compliance with the approved design.



Transport and Installation

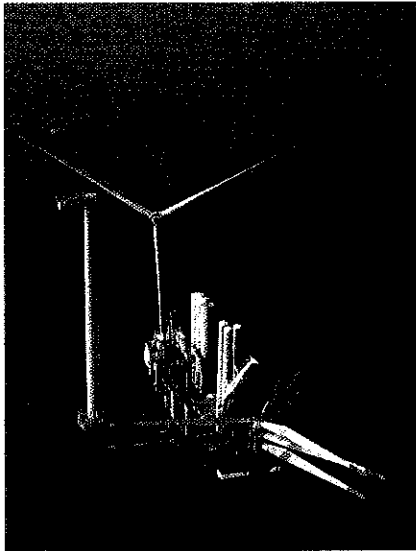

- Transport and installation covers the surveillance during transport and installation of the project related assets.
- Demonstrating that the transport and installation is not interfering with safety and integrity of the assets.



Imperfections at bolted ring-flanges



<p>Turnseitige Winkelklaffung k_T (rotationssymmetrisch)</p>	
<p>Flanchoseitige Winkelklaffung k_F (rotationssymmetrisch)</p>	
<p>Parallelklaffung k_P (über einen begrenzten Umfangswinkel φ)</p>	

When things went wrong...

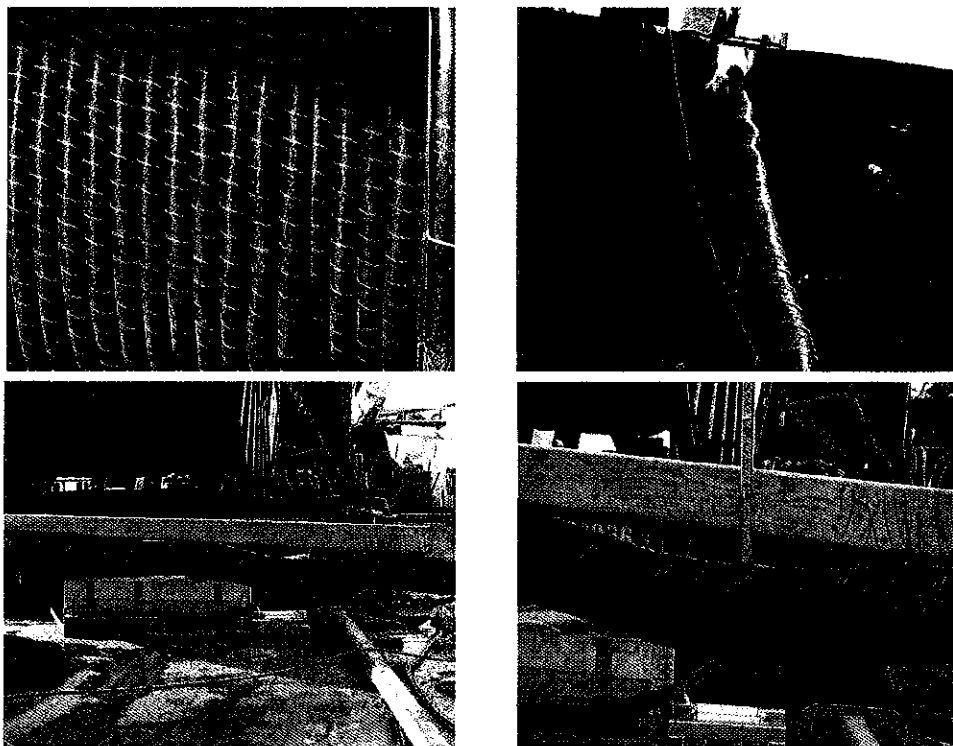

Commissioning, operation and maintenance



- Commissioning involves all follow-up evaluation and on-site inspections during the implementation of the project.
- Operation and maintenance relates to the concepts and manuals to be approved.
- Demonstrating that the assets are ready for a safe and reliable operation.



Installation / Operation – tower connection

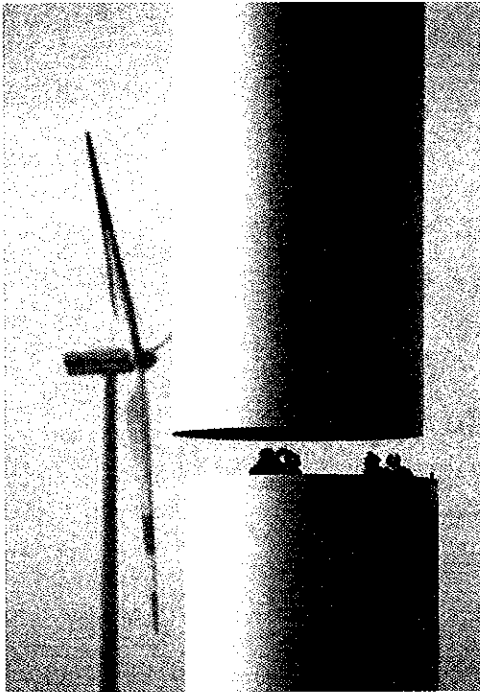

Source: BWE



In-service / periodic monitoring



- In-service involves follow-up evaluation and periodic on-site inspections after start of operation and the power plant lifetime.
- Demonstrating reliable operation over the lifetime by independent survey and evaluation of the asset conditions on a regular basis.

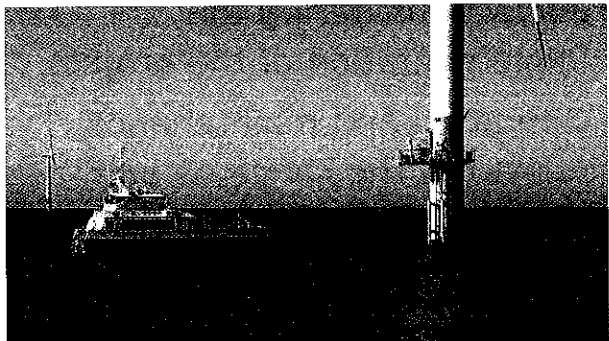

We work with the best

DNV GL is proud to be working with the best in the industry. And when it comes to breaking new ground and ensuring lifetime performance - **experience matters.**

- More than **40 years of experience in wind energy**
- Active in **developing standards, guidelines and specifications** for wind turbine structures and components
- by **continuing the own scheme and make it continuously better** since 1986 (first wind guideline)
- Leading role in developing and revising **international standards** through active involvement in International Electrotechnical Commission (IEC) committees and European and national standards bodies
- **Accredited by** global accreditation body **DAkkS** to provide certification services

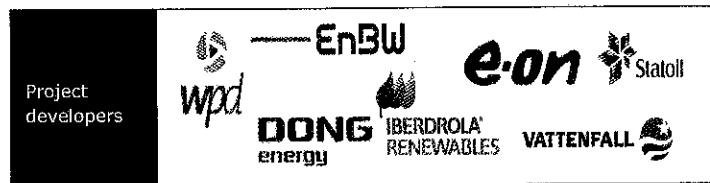
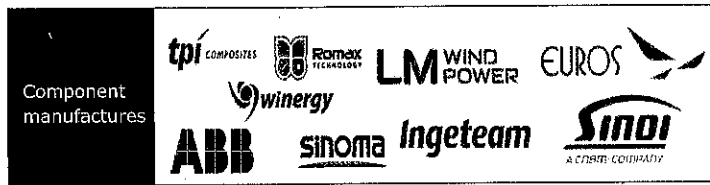

Thank you for your attention!

Fabio Pollicino

E-Mail: fabio.pollicino@dnvgl.com

Tel.: +49 (0) 40 - 3 61 49 - 70 57

Mobile: +49 (0) 172 - 511 43 17



www.dnvgl.com

SAFER, SMARTER, GREENER

