

CODE OF PRACTICE

ON

POLLUTION CONTROL

First Edition	Jan 1994
Second Edition	Jan 1996
Third Edition	Feb 2000
Third Edition	Feb 2001
(with amendments)	Jun 2002
	Feb 2004
	Feb 2009

CONTENTS

INTRODUCTION

TERMINOLOGY

- 1 **JUDICIOUS SITING OF INDUSTRIES**
- 2 **REQUIREMENTS FOR INDUSTRIES, WAREHOUSES AND BUSINESS PARKS**
 - 2.1 Clean Industry
 - 2.2 Light Industry ([amended in Jun 2002](#))
 - 2.3 General Industry
 - 2.4 Special Industry
 - 2.5 Warehouses
 - 2.6 Business Parks
- 3 **CLEARANCE, WRITTEN APPROVAL, LICENCE AND PERMIT REQUIRED TO OPERATE A FACTORY**
 - 3.1 Clearance on the Use of Industrial Premises
 - 3.2 Written Approval
 - 3.3 Licence
 - 3.4 Permit ([amended in Feb 2001](#))
- 4 **POLLUTION CONTROL REQUIREMENTS**
 - 4.1 Water Pollution Control ([amended in Jun 2002](#))
 - 4.2 Air Pollution Control
 - 4.3 Noise Pollution Control
- 5 **HAZARDOUS SUBSTANCES CONTROL** ([amended in Jun 2002](#))
- 6 **TOXIC INDUSTRIAL WASTES CONTROL**

- 7 **CONTROL OF LAND POLLUTION AND REMEDIATION OF
CONTAMINATED SITES** (amended in Jun 2002)
 - 7.1 Pollutive Activities
 - 7.2 Site Assessment Study and Clean-up of Contaminated sites
 - 7.3 Standards and Technical Guidelines for Assessment and Remediation of
Sites
 - 7.4 List of Third Party Consultants
 - 7.5 Certification of Remediated Sites

- 8 **PROCEDURE FOR OBTAINING BUILDING PLAN APPROVAL AND
TEMPORARY OCCUPATION PERMIT/CERTIFICATE OF
STATUTORY COMPLETION**

Appendix

- 1 List of Clean Industries
- 2 List of Light Industries
- 3 List of General Industries
- 4 List of Special Industries
- 5 List of Scheduled Premises
- 6 List of Toxic Industrial Wastes
- 7 List of Hazardous Substances ([amended in Feb 2009](#))
- 8 List of Specified Quantities of Hazardous Substances ([amended in Feb 2009](#))
- 9 Allowable Limits for Trade Effluent Discharge ([amended in Feb 2009](#))
- 10 Trade Effluent Tariff Scheme ([amended in Jun 2002](#))
- 11 Trade Effluent Sampling Sump
- 12 Requirement on Continuous On-Line pH Monitoring and Effluent Discharge Control at Last Inspection Chamber of Factory ([amended in February 2004](#))
- 13 Installation of pH Meter and Penstock
- 14 Guidelines for Leak Test
- 15 Guidelines for Contingency Plan
- 16 Recommendation on Storage of Hazardous Substances
- 17 Retention Basin for Fire-Fighting Water for Warehouse Storing Hazardous Substances
- 18 Dilution Tank
- 19 Standards of Concentration of Air Impurities ([amended in Feb 2009](#))
- 20 Allowable Boundary Noise Limits for Factory Premises
- 21 Pollutive Activities Subject to Site Assessment Before Change of Use or Rezoning ([amended in Jun 2002](#))

INTRODUCTION

Environmental impact due to developments and related pollution problems can be mitigated by ensuring that such developments are sited in designated areas and pollution control measures are incorporated in the design of the developments. Control at the planning stage is, therefore, important in the prevention of pollution.

Planning and development authorities consult the Pollution Control Department (PCD) of the Ministry of the Environment (ENV) on the siting requirements for new developments and compatibility with the surrounding land use. PCD also checks at this early stage that the level of environmental management and control of the proposed developments is acceptable.

Before a proposed development can be constructed under the Building Control Act, the developer must submit Building Plans (BPs) of the building works to the Building Plan and Management Division of the Building and Construction Authority (BCA) for approval.

Before BCA approves the BPs, the BPs will have to be submitted and cleared by various authorities such as the Fire Safety Bureau (FSB), National Parks Board, ENV, etc. In ENV, the Central Building Plan Unit (CBPU) of PCD issues clearance of BPs subject to compliance with sewerage, drainage, environmental health and pollution control requirements. Technical requirements on pollution control are stipulated in the Environmental Pollution Control Act and its regulations, and the Code of Practice on Pollution Control.

A Working Committee was tasked to review and update the technical requirements in the Code of Practice on Pollution Control. The Working Committee comprised ENV officers and representatives from the Association of Consulting Engineers Singapore (ACES), Institute of Engineers Singapore (IES) and Singapore Institute of Architects (SIA) as follows:

- (a) Mr Foong Chee Leong (Chairman)
Pollution Control Department, ENV
- (b) Mr Tan Wee Hock
Pollution Control Department, ENV
- (c) Mr Koh Sek Tong
Pollution Control Department, ENV
- (d) Mr Hui Kok Choy
Pollution Control Department, ENV
- (e) Er Tony Tay Chye Teck
Association of Consulting Engineers Singapore

- (f) Er Loh Chew Thong
The Institution of Engineers, Singapore
- (g) Dr Chris Vickery
Singapore Institute of Architects
- (h) Madam Eng Yew Hoon
Singapore Institute of Architects

The aim of the Code of Practice is to inform industrialists, architects, professional engineers and consultants on pollution control requirements for the submission of development proposals and BPs. The requirements in the Code of Practice have been changed from prescription-based to performance-based ones. The objective is to enable industrialists, architects, professional engineers and consultants to exercise flexibility and creativity in their designs and at the same time meet the requirements.

The latest edition of this Code of Practice contains eight sections as follow:

- (a) Judicious Siting of Industries.
- (b) Requirements for Industries, Warehouses and Business Parks.
- (c) Clearance, Written Approval, Licence and Permit to Operate a Factory.
- (d) Pollution Control Requirements.
- (e) Hazardous Substances Control.
- (f) Toxic Industrial Wastes Control.
- (g) Control of Land Pollution and Remediation of Contaminated Sites
- (h) Procedure for Obtaining Building Plan Approval and Temporary Occupation Permit/Certificate of Statutory Completion.

General amendments and revisions are expected from time to time and any major changes will be made known to the Association of Consulting Engineers Singapore, Institution of Engineers Singapore and Singapore Institute of Architects.

Clarification on any aspect of this Code of Practice may be made with the Pollution Control Department, National Environment Agency, Singapore.

TERMINOLOGY

“air impurities” includes smoke, cinders, solid particles of any kind, gases, fumes, odours and radioactive substances.

“fuel burning equipment” means any furnace, boiler, fire place, oven, retort or incinerator.

“hazardous substance” means any of the substances listed in the first column of Part I of Appendix 7 but shall not include –

- (a) such substance when contained in any substance, preparation or product specified in the second column of Part I corresponding to that substance; or
- (b) such substance when contained in any substance, preparation or product specified in Part II of Appendix 7.

“public sewer” includes

- (a) a sewer which was vested in the Government before the appointed day under the repealed Water Pollution Control and Drainage Act (Chapter 238) or any other written law;
- (b) a sewer with respect to which a declaration of vesting has been made under Section 9 of the Sewerage and Drainage Act;
- (c) a sewer constructed by the Government on any private property at its expense or acquired by the government; and
- (d) a sewer erected on private property which is maintained by the Government.

“pollutive substance” means any oil, solvent or chemical that can cause pollution to a watercourse.

“scheduled premises” means any premises listed in Appendix 5.

“sewage” includes water-borne domestic waste and trade effluent.

“storm water” means rainwater or surface water but does not include sewage.

“toxic industrial waste” means any of the wastes listed in Appendix 6.

“trade effluent” means any liquid, either with or without particles of matter in suspension therein, which is the outflow from any trade, business or manufacture or of any works of engineering or building construction.

“unprotected water catchment” means an area from which potable water supplied by the Public Utilities Board (PUB) is obtained but does not include a watercourse from which water is pumped into a main of PUB.

“watercourse” includes a reservoir, lake, river, stream, canal, drain, spring or well or a part of the sea abutting on the foreshore and any other natural, artificial or sub-surface body of water.

“controlled watercourse” means a watercourse from which potable water supplied by PUB under the Public Utilities Act is obtained but does not include a watercourse from which water is pumped into a main of PUB.

1 JUDICIOUS SITING OF INDUSTRIES

- 1.1 Environmental impact can be mitigated by ensuring that any development is sited in a designated area and pollution control measures are incorporated in its design. It is, therefore, important at the planning stage of any development project for the architect, professional engineer and developer to ascertain the impact of the development in relation to the surrounding environment and vice versa. The measures to control air, water and noise pollution, the management of hazardous substances, and the treatment and disposal of toxic wastes should be examined and indicated clearly in the development proposal.
- 1.2 To guide land use planning and help industrialists select suitable industrial premises, industries are classified under 4 categories namely clean, light, general and special industries based on the impact of residual emissions of fumes, dust and noise on surrounding land use.
- 1.3 Depending on their scale of operations, food industries are also classified into light, general or special category. However, in order to prevent cross-contamination due to residual emissions from neighbouring premises, food industries shall be sited in industrial premises in areas designated as food zones or in areas with compatible industrial uses.
- 1.4 Industrial premises located close to residential areas and within unprotected water catchments shall be allocated to clean or light industries only.
- 1.5 Warehouses located within unprotected water catchments shall not be used for bulk storage of hazardous or pollutive substances.
- 1.6 To minimise risk from the handling of hazardous substances, special industries which use large quantities of such chemicals are sited on off-shore islands or industrial estates which are located away from residential estates.

2 REQUIREMENTS FOR INDUSTRIES, WAREHOUSES AND BUSINESS PARKS

2.1 Clean Industry

- (a) No buffer is required.
- (b) Factory shall not generate air and water pollution as well as noise and smell nuisance that can affect neighbouring premises.

- (c) Factory shall not use large quantities of hazardous substances such as solvents, acids and other chemicals.
- (d) A list of some clean industries is given in **Appendix 1**.

2.2 Light Industry

- (a) There shall be a buffer distance of at least 50m between a light industrial building and the nearest residential building.
- (b) [Factory shall not use equipment burning solid or fuel oil. Boilers using diesel \(0.005%S\) and heating equipment such as furnaces, ovens and autoclaves using gaseous fuel or electricity may be allowed.](#)
- (c) Factory shall not generate large quantities of trade effluent or solid waste.
- (d) Factory shall not generate excessive impulsive or continuous noise.
- (e) Factory shall not use large quantities of hazardous substances such as solvents, acids and other chemicals.
- (f) A list of some light industries is given in **Appendix 2**.

2.3 General Industry

- (a) There shall be a buffer distance of at least 100m between a general industrial building and the nearest residential building.
- (b) Factory shall install, operate and maintain pollution control equipment to minimise air, water and noise pollution arising from its operations as specified by the Pollution Control Department (PCD).
- (c) A list of some general industries is given in **Appendix 3**.

2.4 Special Industry

- (a) There shall be a buffer distance of at least 500m between the boundaries of a factory and the nearest residential building.
- (b) Special industries, which can potentially cause serious pollution such as oil refineries, petrochemical and chemical plants, toxic industrial wastes treatment facilities, etc, shall be sited at least 1 km from the nearest residential building.

- (c) Factory shall install, operate and maintain pollution control equipment to minimise air, water and noise pollution arising from its operations as specified by PCD.
- (d) Developers of special industries using or storing large quantities of hazardous chemicals may be required to conduct the following studies:
 - (i) **Quantitative Risk Assessment (QRA) Study**
 - To identify and quantify hazards and risks related to the transport, use and storage of hazardous chemicals;
 - To determine impact zones due to an accident which will lead to fire, explosion or release of toxic gases (the impact zones shall not extend to any residential building);
 - To recommend measures to be incorporated in the design and operation of the plant to keep risks to a low level and to minimise impact zones; and
 - To facilitate the development of emergency response plans to deal with all credible accident scenarios.
 - (ii) **Pollution Control (PC) Study**
 - To identify the sources of emission of air pollutants, discharge of trade effluent, generation of wastes and emission of noise; and
 - To propose measures to reduce pollution and to mitigate adverse pollution impact on surrounding land use.
- (e) A list of some special industries is given in **Appendix 4**. Special industries also include industries that have the potential to cause serious air pollution or that store large quantities of hazardous substances classified as Scheduled Premises. A list of Scheduled Premises is given in **Appendix 5**.

2.5 Warehouses

- (a) Warehouses located within unprotected water catchments are not allowed to store hazardous or pollutive substances.

- (b) Warehouses storing toxic and hazardous substances shall be provided with pollution control facilities.

2.6 **Business Parks**

- (a) No buffer is required.
- (b) Activities shall not generate air and water pollution as well as noise and smell nuisance that can affect neighbouring premises.
- (c) Activities can include high technology manufacturing, research and development, product design and development, data processing, software development and industrial training that do not require the use or storage of significant quantities of hazardous substances and solvents.

3 **CLEARANCE, WRITTEN APPROVAL, LICENCE AND PERMIT REQUIRED TO OPERATE A FACTORY**

3.1 **Clearance on Use of Industrial Premises**

Prospective industrialists shall obtain clearance from PCD on the use of industrial premises. At this stage of industrial development, PCD screens prospective industries for compliance with the following:

- (a) the premises is sited in a designated industrial estate and is compatible with the surrounding land use.
- (b) clean technology is adopted to minimise the use of hazardous substances and the generation of wastes. The processes used will facilitate recycling, reuse and recovery of the wastes.
- (c) the use or storage of hazardous substances will not pose unmanageable health and safety hazards and pollution problems.
- (d) the discharge of trade effluent and emission of air impurities can comply with discharge or emission standards.
- (e) the wastes generated can be safely managed and properly disposed of.

3.2 **Written Approval**

A written approval is required for any person to discharge trade effluent into a public sewer.

3.3 **Licence**

- (a) A licence is required for any person to discharge trade effluent into a watercourse or controlled watercourse.
- (b) A licence is required for any person to occupy and use any industrial premises classified as Scheduled Premises. Industries that have the potential to cause serious air pollution or that store large quantities of hazardous substances are classified as Scheduled Premises. A list of Scheduled Premises is in **Appendix 5**.
- (c) A licence is required before any person can set up and operate a disposal facility for toxic industrial wastes listed in **Appendix 6**.
- (d) A licence is required for any person to collect or accept any toxic industrial waste for storage, processing, use, treatment or disposal.
- (e) A licence is required for any person to import, sell or export hazardous substances which are listed in **Appendix 7**. Approval is also required to transport hazardous substances exceeding quantities specified in **Appendix 8**.

3.4 **Permit**

A permit is required for any person to store, purchase or use any hazardous substances [excluding ozone depleting substances except for methyl bromide](#).

3.5 **Application for Clearance, Written Approval, Licence and Permit**

Guidelines and forms on the application for Clearance, Written Approval, Licence and Permit are available on the NEA web-site at: <http://www.nea.gov.sg/info/cbpu>

4 **POLLUTION CONTROL REQUIREMENTS**

Industrial developments shall be designed and incorporated with pollution control facilities to reduce and control pollution so as to minimise any adverse pollution impact on surrounding developments.

4.1 **Water Pollution Control**

4.1.1 **General Requirements**

- (a) Trade effluent shall be treated to the allowable limits before discharge into a public sewer, or into a watercourse if public sewer is not available. The limits for the discharge of trade effluent into a public sewer and watercourse are given in **Appendix 9**.
- (b) Trade effluent containing Biochemical Oxygen Demand (BOD) and Total Suspended Solids (TSS) exceeding the allowable limits may be discharged into a public sewer subject to payment of trade effluent fees as given in **Appendix 10**.
- (c) Rainwater shall not be discharged into a public sewer. It shall be channeled into a watercourse. Contaminated rainwater from process areas shall be collected and treated before discharge into the watercourse.
- (d) Secondary containment facilities shall be provided for storage tanks containing oils and chemicals to contain accidental release of the entire content of the largest storage tank.
- (e) The occupier or owner of any premises shall notify PCD immediately of any accidental release, leakage or spillages of oil or chemical.
- (f) The occupier or owner shall take immediate mitigating measures to control and contain the release, leakage or spillage and to clean up any land, watercourses or other areas affected by the release, leakage or spillage. All wastes generated shall be treated and disposed of safely.

4.1.2 **Specific Requirements**

(a) **Trade Effluent Treatment Plant**

A separate effluent drain-line shall be provided to collect and convey trade effluent generated into a sampling sump before discharge into a sewer. A schematic drawing of the sampling sump is given in **Appendix 11**.

Industries generating trade effluent which does not meet the allowable limits given in **Appendix 9** shall install, operate and maintain a treatment plant to treat the effluent to the allowable limits before discharge.

Diluting trade effluent with potable water, rainwater or industrial water to comply with the allowable limits is not permitted. The trade effluent treatment plant shall be designed and provided with spill containment facilities to channel any spill to the treatment plant for treatment. The containment facilities shall not collect rainwater. A sampling sump as shown in **Appendix 11** or other suitable effluent monitoring or sampling system shall be provided at the final effluent discharge point prior to the connection to a sewer.

For a trade effluent treatment plant, which includes neutralisation, a pH monitoring cum effluent discharge control system shall be provided in the last inspection chamber of the premises. The details of the monitoring and control system are illustrated in **Appendices 12 and 13**.

(b) **Cooling Tower**

The overflow/drain-off of a cooling tower shall be discharged into a public sewer.

(c) **Boiler**

Wastewater from boiler blow-down shall be cooled to below 45°C before discharge into a public sewer.

(d) **Chemical/Oil Store**

A chemical/oil store shall be provided with facilities to contain any leak and spillage. Such an area shall not have any outlet/opening leading to a storm water drain or a sewer. All leaks and spillage shall be collected for proper disposal as toxic industrial wastes.

(e) **Chemical/Oil Bulk Storage Tanks**

A full containment facility shall be provided for underground or above ground bulk storage tanks (including skid tanks). The capacity of the containment facility shall not be less than the capacity of the largest tank. For a secondary containment facility that is fully enclosed, a leak detection system with an alarm device shall be provided within the secondary containment facility. A leak test shall be conducted before the tank is put into

use. The leak test shall conform to the guidelines given in **Appendix 14**. A contingency plan shall be developed and put in place to deal with leaks. The contingency plan shall meet the requirements given in **Appendix 15**.

For an elevated storage tank, the secondary containment facility shall be provided with measures to contain a shooting jet of chemical/oil escaping from a rupture in the tank.

For a secondary containment facility exposed to the weather, it shall be provided with a system to discharge rainwater collected in the containment facility. The discharge system shall be designed and operated to allow only rainwater to be discharged. If the rainwater is contaminated, it shall be treated before discharge into a watercourse.

The connection point for a filling pipe of a bulk storage tank shall be provided with measures to contain spillage.

(f) **Chemical Warehouses**

(i) Separate fire compartments shall be provided for the storage of substances that can react dangerously with one another. Substances in the same hazard categories may be stored together as long as the compartment is protected against the most hazardous substance. Recommendation on the storage of hazardous substances is given in **Appendix 16**.

(ii) A retention basin for fire fighting water shall be provided for the storage of hazardous substances.

(iii) The capacity of the retention basin depends on whether a fire compartment is provided with automatic fire extinguishing system such as water sprinklers. A smaller retention basin may be provided if an automatic fire extinguishing system is installed. The recommended volume of the retention basin for fire fighting water is given in **Appendix 17**.

(iv) The floor of the chemical warehouse shall be coated with a layer of chemical-resistant material.

(g) **Laboratory**

Wastewater generated from a chemical analysis laboratory shall be discharged into a sewer via a balancing tank, which is also known as a dilution tank. A sketch of the tank is shown in **Appendix 18**.

If there is more than one chemical analysis laboratory, a common balancing tank may be provided to serve the laboratories. The wastewater from the laboratories may also be discharged into a trade effluent treatment plant, if one is provided.

Wastewater generated from a biological/food analysis laboratory, however, shall be discharged directly into a sewer.

(h) **Aquacultural Farm**

Trade effluent generated from aquacultural farms shall be treated to comply with the allowable limits before it is discharged into a watercourse. If the trade effluent does not include rainwater, it may be treated for discharge into a public sewer.

Sludge, if generated, shall be stabilised, dewatered and disposed of as solid waste.

(i) **Livestock Farm**

Livestock shall not be reared in the open. Proper covered sheds shall be erected for the rearing of livestock.

Trade effluent generated shall be collected and treated to comply with the allowable discharge limits before discharging into a public sewer or watercourse where a public sewer is not available.

Animal wastes and sludge generated from wastewater treatment shall be stabilised, dewatered and disposed of as solid waste.

Poultry wastes may be collected for disposal as solid wastes. The wastes shall be stored inside a storage shed with a containment facility.

(j) **Horticultural Farm**

Pesticides and fertilizers that are approved by PCD or the [Agri-food and Veterinary Authority of Singapore \(AVA\)](#) shall be used. For farms within unprotected water catchments, the pesticides and fertilizers used shall also be approved by PUB. The pesticides and fertilizers shall be applied strictly in accordance with the guidelines of the manufacturers or distributors to prevent pollution of surface water.

4.2 **Air Pollution Control**

- (a) The use of open fire to dispose of waste wood, timber and other combustible wastes is prohibited.
- (b) Trade and industrial premises, which carry out activities that can generate air impurities, are required to install, operate and maintain air pollution control equipment properly and efficiently. The pollution control equipment shall be designed to comply with the allowable emission standards. The emission standards for air impurities are given in **Appendix 19**. For air impurities with no prescribed emission standards, the best practical means shall be adopted to minimise air pollution. Exhaust gases from the pollution control equipment shall be emitted into the atmosphere through a discharge stack of a height approved by PCD to ensure safe dispersion.
- (c) Fuel burning equipment shall be efficiently operated and maintained. The fuel burning equipment shall use a fuel approved by PCD. The sulphur content of the fuel will be specified by PCD to ensure that the emission of sulphur dioxide would not affect ambient air quality. Fuel burning equipment installed at industrial premises that are sited within 100m of any residential building shall use gaseous fuel or diesel with a sulphur content of not more than 0.005% by weight.
- (d) A chimney of an approved height shall be provided for the safe dispersion of flue gases from fuel burning equipment. The height of the chimney is computed based on the mass of sulphur dioxide emitted and the height of buildings in the vicinity. The minimum height shall be at least 3m above roof level of the factory building or 15m measured from ground level whichever is the higher.
- (e) Monitoring equipment shall be provided at the discharge stacks and chimneys to monitor air impurities emitted. The monitoring equipment shall be installed in accordance with the technical specifications of the equipment supplier to give accurate readings. If sampling ports are provided for manual installation of portable sampling equipment, the ports shall be installed such that they are accessible. As an alternative to monitoring the emission of air impurities at discharge stacks or chimneys, equipment may be provided to monitor the performance of automatic devices used to secure more efficient operation of any pollution control or fuel burning equipment.
- (f) Special waste incinerators for toxic industrial wastes shall be designed and operated to comply with emission standards to be specified by PCD.

4.3 Noise Pollution Control

- (a) All practical noise abatement measures shall be adopted to comply with the allowable boundary noise levels. The allowable boundary noise levels are given in **Appendix 20**.
- (b) For clean or light industries located adjacent to noise-sensitive and residential developments, mechanical equipment such as air compressors, chillers, cooling towers and air-conditioners, etc. shall be sited as far away as practical from the noise-sensitive and residential buildings. Noise abatement measures, if required, shall be provided to comply with the allowable boundary noise levels.

5 HAZARDOUS SUBSTANCES CONTROL

- (a) Companies that import, store and use hazardous substances are required to obtain licences/permits from PCD. They are also required to obtain approval from PCD to transport hazardous substances exceeding specified quantities. The controls are to ensure that preventive measures are taken to minimize accidental releases of hazardous substances into the environment and emergency response plans are put in place to deal with all credible accident scenarios of release of hazardous substances. The preventive measures include the following:
 - (i) containers constructed and inspected in accordance with internationally acceptable standards are used for the storage of hazardous substances and affixed with approved labels;
 - (ii) storage areas are equipped with containment as well as disposal facilities to deal with any accidental release of hazardous substances;
 - (iii) route and time of transportation are specified for the transportation of hazardous substances exceeding specified quantities;
 - (iv) drivers of road tankers and tankers carrying hazardous substances are required to undergo a special training course on safety requirements and precautions, first aid and fire fighting and a refresher course once every three years.
 - (v) The owner or consignor of any consignment of any hazardous substance shall notify immediately of any accidental release, leakage or spill of hazardous substances during transport.

- (vi) The owner or consignor shall ensure immediate mitigating measures are taken to control and contain the release, leakage or spill and clean up any land, drain or water courses affected by the release, leakage or spill. All wastes generated shall be treated and disposed of safely.
- (b) Companies that are licensed to store and use large quantities of hazardous substances are required to carry out a safety audit to systematically identify and rectify weakness in their management systems and practices for handling hazardous substances on a regular basis. The companies can either conduct their own safety audits in-house or engage accredited consultants to do so on their behalf.

6 TOXIC INDUSTRIAL WASTES CONTROL

- (a) Factories are required to install in-house treatment facilities to recycle and reuse their toxic waste or to treat their toxic waste for safe disposal. Factories may, however, apply for clearance from PCD to engage licensed toxic industrial waste collectors to collect their wastes for recycling or treatment for safe disposal.
- (b) Pathogenic wastes are listed as toxic industrial wastes. Hospitals and polyclinics are required to segregate pathogenic wastes and put in colour coded plastic bags. The wastes are then stored in special containers for collection by licensed toxic industrial waste collectors for disposal in high temperature incinerators.
- (c) Operators of specialised toxic waste recycling, treatment and disposal plants are required to obtain licences from PCD to collect, treat and dispose of toxic industrial wastes from industries. They are also required to obtain approval to transport toxic industrial wastes exceeding specified quantities. The controls are to ensure that all toxic industrial wastes are collected, treated and disposed of in compliance with the stipulated standards. The operators are required to maintain a proper record on collection, treatment and disposal of toxic industrial wastes.

7 CONTROL OF LAND POLLUTION AND REMEDIATION OF CONTAMINATED SITES

When a site that is used for **pollutive activities** is to be redeveloped, rezoned or reuse for a non-pollutive activity, a study shall be conducted on the site to assess extent of land contamination. If the site assessment study shows that the site is contaminated, the contaminated site shall be cleaned up to standards acceptable or the intended use.

7.1 Pollutive Activities

A list of pollutive activities is at **Appendix 21**.

7.2 Site Assessment Study and Clean-up of Contaminated Sites

Owners/occupiers or the prospective buyers/lessees may carry out the site assessment study and clean up using in-house or second party experts. The use of inhouse or second party experts is subject to approval from PCD. Alternatively, they may engage a third party specialist consultant with recognised competence in site assessment studies and remediation of contaminated sites to carry out the site assessment study and clean up of the site.

(When a site used for a pollutive activity is to be leased, transferred or sold to another party for the same or other pollutive activity, it is advisable that a site assessment study be conducted to allow parties involved to ascertain extent of existing contamination.

(When a site is to be developed for a pollutive activity, it is advisable that a site assessment study be conducted to establish the baseline soil conditions for future assessment of land contamination.)

A report of the site assessment study and clean-up plan shall be submitted to PCD and shall include the following information:

- (a) Purpose and objective
- (b) Site location and boundaries
- (c) Site ownership
- (d) Party responsible for assessment and management, if not owner.
- (e) Soil consultant's expertise
- (f) Proposed use of site
- (g) History of site - activities of previous owners
- (h) Site assessment standard/methodology adopted
- (i) Site inspection and evidence of possible contamination
- (j) Initial testing - sampling protocol, locations, laboratory used
- (k) Results of soil and groundwater (if applicable) analysis
- (l) Conclusions.

7.3 **Standards and Technical Guidelines for Assessment and Remediation of Sites**

The following standards and technical guidelines may be adopted for site assessment and remediation of contaminated sites:

- (a) Dutch Guidelines for Soil Protection
(More information on the standards can be found at the following website: <http://www2.minvrom.nl/pagina.html/id=5027>)
- (b) ASTM E 1527-00 Standard Practice for Environmental Site Assessments: Phase I Environmental Site Assessment Process
- (c) ASTM E 1903-97 Standard Guide for Environmental Site Assessments: Phase II Environmental Site Assessment Process
- (d) ASTM E1739-95e1 Standard Guide for Risk-Based Corrective Action Applied at Petroleum Release Sites
(More information on the ASTM standards may be obtained from <http://www.astm.org>.)
- (e) Guidelines for Assessing and Managing Petroleum Hydrocarbon Contaminated Sites in New Zealand
(More information on the standards can be found at the following website: http://www.mfe.govt.nz/about/publications/contam_sites/oil/oil_guide.htm)

and any other standards or technical guidelines acceptable to PCD.

7.4 **List of Third Party Specialist Consultants**

A list of third party specialist consultants for site assessment studies and remediation of contaminated sites is at the following website:
<http://www.nea.gov.sg/info/cbpu>

7.5 **Certification of Remediated Sites**

The remediated sites shall be certified by a second party expert or a third party specialist consultant to meet standards required for its proposed landuse. The certification shall contain the following:

- (a) a statement that the subject site has been remediated to meet the standards required for proposed use of the site; and
- (b) a statement that the certification given is a true and unbiased representation of the facts and that all reasonable professional skill, care and diligence have been taken in checking the facts

The originals or authenticated copies of the certification shall be submitted to PCD

**8 PROCEDURE FOR OBTAINING BUILDING PLAN APPROVAL AND
TEMPORARY OCCUPATION PERMIT/CERTIFICATE OF
STATUTORY COMPLETION**

The procedure for obtaining Clearance Certificate for building plan approval and Compliance Certificate for Temporary Occupation Permit/Certificate of Statutory Completion for industrial developments is available on the NEA website at:

<http://www.nea.gov.sg/info/cbpu>

APPENDIX 1

LIST OF CLEAN INDUSTRIES

- 1 Software design and development.
- 2 Product/prototype design, industrial and engineering design.
- 3 Fashion designing.
- 4 Manufacture of polyethylene products (not involving printing operation).
- 5 Assembly and repair of computer hardware, audio-visual equipment, and other communication/electronic equipment, apparatus and parts (not involving spray-painting, electroplating or galvanising operations. Only minor soldering will be allowed).
- 6 Information Technology (IT) technical support/maintenance centres.
- 7 Assembly and repair of office, computing and accounting machinery (not involving spray-painting, electroplating or galvanising operations).
- 8 Assembly and repair of electrical appliances and housewares (not involving spray-painting, electroplating or galvanising operations. Only minor soldering will be allowed).
- 9 Assembly and repair of photographic and optical goods (not involving spray-painting, electroplating or galvanising operations).
- 10 Manufacture and repair of watches and clocks (not involving spray-painting, electroplating or galvanising operations).
- 11 Warehousing activities and storage of finished products such as furniture, electric appliances, garments, canned food and beverages etc.
- 12 Manufacture of paper products without printing activities.
- 13 Manufacture of professional, scientific, measuring and controlling equipment (not involving the use of chemicals, inclusive of gaseous chemicals).
- 14 Diagnostics laboratories and referral laboratories.
- 15 International Specialist and engineering consultancy eg. oil exploration.
- 16 Medical and specialist centres eg. eye institutes, paediatrics, bionic limbs, health screening.

Clean industries are generally compatible to food industries. The food industries to be sited adjacent to clean industries shall not give rise to any emissions that may affect the activities of the clean industries..

APPENDIX 2

LIST OF LIGHT INDUSTRIES

Food industries:

- 1 Packing of dried foodstuff, blending of food ingredients, bottling of syrups/cordial juice.
- 2 Packing and bottling of medicinal herbs and medicated oil.

Others

- 3 Research & Development involving small quantities of chemicals.
- 4 Biotechnology.
- 5 Manufacture of made-up textile goods (except wearing apparel) without dyeing, bleaching and/or other finishing operations.
- 6 Knitting mills without dyeing, bleaching and/or other finishing operations.
- 7 Manufacture of carpets and rugs without dyeing, bleaching and/or other finishing products.
- 8 Manufacture of wearing apparel (except footwear) without dyeing and/or bleaching operations.
- 9 Manufacture of footwear, except for those made of plastic or vulcanised or moulded rubber.
- 10 Manufacture of products of leather and leather substitutes, except footwear and wearing apparel.
- 11 Printing, publishing and allied industries.
- 12 Mould-making without metal stamping, etching or electroplating.
- 13 Manufacture of plastic products, not elsewhere classified.
- 14 Manufacture of containers and boxes of paperboard.
- 15 Manufacture of paper products also involving printing activities without pulping works or bleaching operations.
- 16 Manufacture of aluminium window frames and grills from aluminium extrusions without spraypainting operations.
- 17 Servicing and refilling of fire extinguishers.

Other light industries are generally compatible to food industries. The food industries to be sited adjacent to light industries shall not give rise to any emissions that may affect the activities of the light industries

APPENDIX 3

LIST OF GENERAL INDUSTRIES

Food industries:

- 1 Manufacture of food products (factories not having scheduled boilers):-
 - (i) Those food processing factories such as food catering, confectioneries, which generate wastewater containing high concentration of oil and grease shall be sited in units which are served by a separate sanitary plumbing system connected to a grease trap; and
- 2 Blending of flavours and fragrances.

Others that are compatible to food industries provided they are separated by light industries.

- 3 Manufacture of jewellery and related articles - very small-scale jewellery electroforming operations could be allowed in flatted factories that are used for light industries.
- 4 Manufacture of electrical apparatus and supplies, not elsewhere classified.
- 5 Manufacture of professional, scientific, measuring and controlling equipment, not elsewhere classified.
- 6 Manufacture of musical instruments.
- 7 Manufacture of sporting and athletic goods (not involving woodworking or electroplating operations) - woodworking operations should not be allowed.
- 8 Manufacture of cutlery, hand tools and general hardware.
- 9 Manufacture of emergency lighting and power supply systems.
- 10 Blending of detergents and cleaning preparations, perfumes, hair-care products, cosmetics and other toilet preparations.

Others that are not compatible to food industries and can be considered only if they are located 100m away

- 11 Manufacture of made-up textile goods, with dyeing, bleaching and/or other finishing operations.
- 12 Manufacture of textiles, not elsewhere classified.
- 13 Knitting mills with dyeing, bleaching and/or other finishing operations.
- 14 Manufacture of carpets and rugs with dyeing, bleaching and/or other finishing operations.
- 15 Manufacture of furniture and fixtures, except those made primarily of metal - activities must not include the manufacture of rubber or polyurethane foam.
- 16 Manufacture of wooden and cane containers and small cane wares - bleaching of cane should not be carried out.

- 17 Manufacture of wood and cork products, not elsewhere classified.
- 18 Cordage, rope and twine industries.
- 19 Manufacture of metal drums and containers.
- 20 Manufacture of metallic components using powder metallurgy methods.
- 21 Manufacture of other metallic products involving metal-stamping, wire drawing and spring coiling.
- 22 Manufacture of dry cells and batteries - activities must not include manufacture of metal electrodes.
- 23 Cutting, grinding and polishing of marble and ceramic tiles.
- 24 Manufacturing industries, otherwise classified as clean or light industries, with spray-painting operations.
- 25 Vehicle repair and servicing.
- 26 Repair and maintenance of engines, motors and mechanical pumps.
- 27 Industrial laundry services without scheduled boilers.
- 28 Filling/bottling of inert industrial gases such as nitrogen, helium and argon.
- 29 Storage of chemicals, detergents, oils, solvents, pesticides and related products.
- 30 Storage of rubber products and other odorous products.
- 31 Manufacturing industries, not elsewhere classified.
- 32 Manufacturing of joss sticks.

APPENDIX 4

LIST OF SPECIAL INDUSTRIES

Food industries (obnoxious)

- 1 Slaughtering, preparing and preserving meat.
- 2 Manufacture of dairy products.
- 3 Canning and preserving of fruits and vegetables.
- 4 Canning, preserving and processing of fish, crustaceans and similar food.
- 5 Manufacture of vegetable and animal oils and fats.
- 6 Grain mill products.
- 7 Sugar factories and refineries.
- 8 Manufacture of prepared animal feed.
- 9 Other food-manufacturing industries with scheduled boilers.
- 10 Manufacture of alcoholic products.
- 11 Manufacture of drugs and medicines.

Others that are non compatible to food industries and can be allowed if they are located 100m away

- 12 Manufacture of paints, varnishes and lacquers.
- 13 Other manufacturing industries involving the use of large quantities of organic solvents.
- 14 Assembly of computer hardware, audio-visual equipment, and other communication/ electronic equipment, apparatus and parts involving electroplating.
- 15 Assembly of office, computing and accounting machinery involving electroplating or galvanizing operations.
- 16 Assembly of electrical appliances and housewares involving electroplating or galvanizing operations.
- 17 Assembly of photographic and optical goods involving electroplating or galvanising operations.
- 18 Manufacture of watches and clocks involving electroplating or galvanising operations.
- 19 Manufacture of sporting and athletic goods involving woodworking or electroplating operations.

- 20 Other manufacturing industries with electroplating or galvanising operations.
- 21 Manufacture of furniture and fixtures that are primarily made of metal.
- 22 Iron and steel basic industries.
- 23 Manufacture of structural steel products.
- 24 Non-ferrous metal basic industries.
- 25 Metal-refining industries, including recovery of precious metals.
- 26 Manufacture of fabricated metal products, except machinery and equipment, not elsewhere classified.
- 27 Manufacture of engines and turbines.
- 28 Manufacture of agricultural machinery and equipment.
- 29 Machining of metal and woodworking machinery.
- 30 Manufacture of special industrial machinery and equipment, except metal and woodworking machinery.
- 31 Manufacture of machinery and equipment, except electrical, not elsewhere classified.
- 32 Manufacture of electrical industrial machinery and apparatus.
- 33 Tanneries and leather finishing.
- 34 Dressing and dyeing industries.
- 35 Spinning, weaving and finishing of textiles.
- 36 Manufacture of pulp, paper and paperboard including bleaching operations.
- 37 Sawmills and planing mills.
- 38 Other woodworking industries, not elsewhere classified.
- 39 Manufacture of basic industrial chemicals, except fertilisers.
- 40 Manufacture of fertilisers, pesticides and herbicides.
- 41 Manufacture of soaps and cleaning preparations, perfumes, cosmetics and other toilet preparations (except those without chemical reactions).
- 42 Petroleum refineries.
- 43 Manufacture of synthetic resins, plastic materials and man-made fibres and foams, except those made of glass.
- 44 Manufacture of miscellaneous products of petroleum and coal.
- 45 Manufacture of chemical products, not elsewhere classified.

- 46 Processing of waste oils and waste chemicals.
- 47 Processing of food wastes, including composting plant.
- 48 Bulk storage of hazardous substances.
- 49 Tyre and tube industries.
- 50 Manufacture of rubber products, not elsewhere classified.
- 51 Manufacture of pottery, china and earthen ware.
- 52 Manufacture of glass and glass products.
- 53 Manufacture of structural clay products.
- 54 Manufacture of cement, lime and plaster.
- 55 Manufacture of non-metallic mineral products, not elsewhere classified.
- 56 Industries using radioactive materials.
- 57 Shipbuilding and repairing.
- 58 Manufacture of railroad equipment.
- 59 Manufacture of motor vehicles.
- 60 Manufacture of motorcycles and bicycles.
- 61 Manufacture of aircrafts.
- 62 Manufacture of transport equipment, not elsewhere classified.
- 63 Any other industrial premises classified as scheduled premises.

APPENDIX 5

LIST OF SCHEDULED PREMISES

Scheduled Premises are any premises —

(a) being used for —

- (i) cement works, being works for the manufacture or packing of portland cement, similar cement or pozzolanic materials;
- (ii) concrete works, being works for the manufacture of concrete and of each batch capacity greater than 0.5 cubic metre;
- (iii) asphalt works, being works for the manufacture of asphalt or tarmacadam;
- (iv) ceramic works, being works in which any products such as bricks, tiles, pipes, pottery goods, refractories or glass are manufactured in furnaces or kilns fired by any fuel;
- (v) chemical works, being works in which acids, alkali, chemical fertilizer, soap, detergent, sodium silicates, lime or other calcium compounds, chlorine, chemicals or chemical products are manufactured;
- (vi) coke or charcoal works, being works in which coke or charcoal is produced and quenched, cut, crushed or graded;
- (vii) ferrous and non-ferrous metal works, being works in which metal melting process for casting and/or metal coating are carried out;
- (viii) gas works, being works in which coal, coke, oil or other mixtures or derivatives are handled or prepared for carbonisation or gasification and in which such materials are subsequently carbonised or gasified;
- (ix) crushing, grinding and milling works, being works in which rock, ores, minerals, chemicals or natural grain products are processed by crushing, grinding, milling or separating into different sizes by sieving, air elutriation or in any other manner;
- (x) petroleum works, being works in which crude or shale oil or crude petroleum or other mineral oil is refined or reconditioned;
- (xi) scrap metal recovery works, being works in which scrap metals are treated in any type of furnace for recovery of metal irrespective of whether this is the primary object of any specific premises or not;
- (xii) primary metallurgical works, being works in which ores are smelted or converted to metal of any kind;
- (xiii) pulping works, being works in which wood or cellulose material is made into pulp;
- (xiv) abrasive blasting works, being works in which equipment or structures are cleaned by abrasive blasting;

- (b) on which there is erected any boiler of steam generating capacity of 2,300 kilogrammes or more per hour, incinerator or furnace burning 500 kilogrammes or more of solid combustible material per hour or 220 kilogrammes or more of liquid material per hour;
- (c) being used or intended to be used for storing —
 - (i) more than 100 tonnes of one or more of the following substances: chemicals, chemical products, hydrocarbons or hydrocarbon products which are toxic or which produce toxic gases on burning or on contact with water or air; or
 - (ii) more than 1,000 tonnes of one or more of the following substances: chemicals, chemical products, hydrocarbons or hydrocarbon products with a flashpoint lower than 55°C.

APPENDIX 6

LIST OF TOXIC INDUSTRIAL WASTES

List of Toxic Industrial Wastes
<p><i>Acids</i></p> <ol style="list-style-type: none"> 1. Spent inorganic acids Eg. hydrochloric acid, sulphuric acid, nitric acid, phosphoric acid, hydrofluoric acid, boric acid and pickling acid 2. Spent organic acids Eg. acetic acid, formic acid, benzoic acid and sulphonic acid
<p><i>Alkalis</i></p> <ol style="list-style-type: none"> 1. Spent alkaline solutions 2. Spent ammoniacal solutions 3. Metal hydroxide sludges and oxide sludges
<p><i>Antimony and its Compounds</i></p> <ol style="list-style-type: none"> 1. Spent antimony potassium tartrate
<p><i>Arsenic and its Compounds</i></p> <ol style="list-style-type: none"> 1. Timber preservative residues containing arsenic 2. Wastes containing gallium arsenide
<p><i>Asbestos</i></p> <ol style="list-style-type: none"> 1. Asbestos wastes from asbestos/cement manufacturing processes 2. Empty sacks/bags which have contained loose asbestos fibre
<p><i>Cadmium and its Compounds</i></p> <ol style="list-style-type: none"> 1. Plating effluents and residues containing cadmium 2. Wastes containing cadmium from Ni/Cd battery manufacturing
<p><i>Chromium Compounds</i></p> <ol style="list-style-type: none"> 1. Plating effluents and residues containing chromium 2. Timber preservative residues containing chromium 3. Spent and aqueous solutions containing chromium compounds 4. Tannery effluents and residues containing chromium
<p><i>Copper Compounds</i></p> <ol style="list-style-type: none"> 1. Plating effluents and residues containing copper 2. Spent etching solutions containing copper from printed circuit board manufacturing 3. Timber preservative residues containing copper
<p><i>Cyanides</i></p> <ol style="list-style-type: none"> 1. Plating effluents and residues containing cyanides 2. Heat treatment residues containing cyanides 3. Spent quenching oils containing cyanides 4. Spent processing solutions containing cyanides from photographic processing
<p><i>Fluoride Compound</i></p> <ol style="list-style-type: none"> 1. Timber preservative residues containing fluorides 2. Spent ammonium bi-fluoride
<p><i>Isocyanates</i></p> <ol style="list-style-type: none"> 1. Spent di-isocyanates Eg. toluene di-isocyanate (TDI) and methylene di-isocyanate (MDI) from polyurethane foam-making process

List of Toxic Industrial Wastes
<p>Laboratory Wastes</p> <ol style="list-style-type: none"> 1. Obsolete laboratory chemicals 2. Toxic chemical wastes from chemical analysis
<p>Lead Compounds</p> <ol style="list-style-type: none"> 1. Sludges containing lead oxide/sulphate 2. Spent organo-lead compounds Eg. tetraethyllead (TEL) and tetramethyllead (TML) 3. Waste lead-acid batteries, whole or crushed
<p>Mercury and its Compounds</p> <ol style="list-style-type: none"> 1. Effluents, residues or sludges containing mercury from chlor-alkali industry 2. Wastes containing mercury from equipment manufacturing involving the use of metal mercury 3. Spent catalysts from chemical processes containing mercury 4. Spent organo-mercury compounds
<p>Metal Catalysts</p> <ol style="list-style-type: none"> 1. Spent metal catalysts from chemical processes and petroleum refining Eg. catalysts containing chromium and cobalt
<p>Nickel Compounds</p> <ol style="list-style-type: none"> 1. Plating effluents and residues containing nickel
<p>Organic Compounds containing Halogen</p> <ol style="list-style-type: none"> 1. Spent halogenated organic solvents Eg. trichloroethylene, 111-trichloroethane, perchloro-ethylene, methylene chloride, tetrachloromethane and 112-trichloro-122-trifluoroethane 2. Residues from recovery of halogenated organic solvents 3. Packaging materials or residues containing chloro-benzenes and/or chlorophenols and their salts
<p>Organic Compounds not containing Halogen</p> <ol style="list-style-type: none"> 1. Spent non-halogenated organic solvents Eg. benzene, toluene, xylene, turpentine, petroleum, thinner, kerosene, methanol, ethanol, isobutanol, iso-propanol, methyl ethyl ketone, methyl isobutyl ketone, isopropyl ether, diethyl ether, hexane, dimethyl sulphide and dimethyl sulphoxide 2. Residues from recovery of non-halogenated organic solvents
<p>Other Wastes</p> <ol style="list-style-type: none"> 1. Obsolete/abandoned chemicals and pesticides from storage, manufacturing and trading activities 2. Used containers, bags and process equipment contaminated by chemicals and pesticides from storage, manufacturing and trading activities 3. Wastes/residues containing unreacted monomers, eg. vinyl chloride and styrene monomers, from polymer manufacturing processes 4. Tar residues from distilling and tarry materials from refining 5. Wastes from toxic waste treatment processes Eg. wastes and residues from solidification, fixation and incineration processes 6. Wastes from toxic chemical drums and tank cleaning activities 7. Chemical and oil slops from ship tankers 8. Wastes from the production, formulation and use of resins, latex, plasticisers, glues/adhesives containing solvents and other contaminants. 9. Wastes from the production, formulation and use of inks, dyes, pigments, paints, lacquers, varnish containing organic solvents, heavy metals or biocides.

List of Toxic Industrial Wastes
<p><i>Pathogenic Wastes</i></p> <ol style="list-style-type: none"> 1. Pathogenic wastes from hospitals
<p><i>Phenolic Compounds</i></p> <ol style="list-style-type: none"> 1. Sludges/residues from paint stripping using chemicals containing phenols 2. Residues containing unreacted phenol and formaldehyde from adhesive industry
<p><i>Polychlorinated Bi-phenyl (PCB) including Poly-chlorinated Ter-phenyl (PCT)</i></p> <ol style="list-style-type: none"> 1. Spent transformer oil containing PCB and/or PCT 2. Retrofilled transformer contaminated with PCB and/or PCT 3. Electrical equipment and parts containing or contaminated with PCB and/or PCT Eg. Capacitors and transformers 4. Containers and all waste materials contaminated with PCB and/or PCT
<p><i>Polyvinyl Chloride (PVC)</i></p> <ol style="list-style-type: none"> 1. All waste materials containing PVC Eg. PVC insulated wires, PVC pipes and trunking, PVC parts, PVC upholstery and PVC resins
<p><i>Silver Compounds</i></p> <ol style="list-style-type: none"> 1. Spent processing solutions containing silver from photographic processing
<p><i>Used, Contaminated Oil</i></p> <ol style="list-style-type: none"> 1. Used mineral, lubricating and hydraulic oil from machine cylinders, turbines, switch gears and transformers 2. Spent motor oils from petrol and diesel engines 3. Spent quenching oil from metal hardening 4. Oil recovered from solvent degreasers 5. Spent oil water emulsions Eg. Spent coolants from metal working industries 6. Oil water mixtures (mainly oil) Eg. Oily ballast water from ship tankers 7. Oil and sludge from oil interceptors 8. Tankers sludges and oil sludges/residues from storage tanks 9. Oil sludges containing acid from recovery and recycling of used oil
<p><i>Zinc Compounds</i></p> <ol style="list-style-type: none"> 1. Plating effluents and residues containing zinc

APPENDIX 7

LIST OF HAZARDOUS SUBSTANCES

Part I – Hazardous substances

Hazardous Substances	
Substance	Exclusion
I,2-dibromoethane (EDB)	
Acetic acid	Substances containing not more than 80%, weight in weight, of acetic acid; Preparations and solutions for photographic use.
Acetyl bromide	
Allyl isothiocyanate	
Alkali metal bifluorides; Ammonium bifluoride; Potassium fluoride; Sodium fluoride; Potassium silicofluoride; Sodium silicofluoride; Silicofluoric acid	Preparations containing not more than 0.3%, weight in weight, of potassium fluoride in radiator protectors; Preparations containing not more than 0.96%, weight in weight, of potassium fluoride in photographic chemicals; Substances containing not more than 3%, weight in weight, of sodium fluoride or sodium silicofluoride as a preservative; Substances containing sodium fluoride intended for the treatment of human ailments.
Ammonia	Preparations and solutions of ammonia containing not more than 10%, weight in weight, of ammonia; Refrigeration equipment; Photographic and plan developers; Hair colour dyes; Perm lotions; Smelling bottles.
Ammonium chlorate	
Anionic surface active agents	Preparations containing less than 5% by weight of anionic surface active agents; Preparations containing anionic surface active agents which are not less than 90% biodegradable under a test carried out in accordance with that part of the OECD method which is referred to as 'Confirmatory Test Procedure' in European Communities Council Directive No. 73/405/EEC (C) or other equivalent test methods acceptable to the Director.
Antimony pentachloride	Polishes
Antimony trihydride	
Arsenical substances, the following: Arsenic acid	Pyrites ores or sulphuric acid containing arsenical poisons as natural impurities; Animal feeding stuffs containing not more than 0.005%, weight in weight, of 4-hydroxy-3-nitrophenyl-arsonic

Arsenic sulphide	acid and not containing any other arsenical poison;
Arsenic trichloride	Animal feeding stuffs containing not more than 0.01%, weight in weight, of arsanilic acid and not containing any other arsenical poison;
Arsine	Animal feeding stuffs containing not more than 0.0375%, weight in weight, of carbarson and not containing any other arsenical poison.
Calcium arsenite	
Copper arsenate	
Copper arsenite	
Lead arsenate	
Organic compounds of arsenic	
Oxides of arsenic	
Potassium arsenite	
Sodium arsenate	
Sodium arsenite	
Sodium thioarsenate	
Asbestos in the form of crocidolite, actinolite, anthophyllite, amosite, tremolite, chrysotile and amphiboles and products containing these forms of asbestos	Asbestos in the form of chrysotile in any vehicle brake or clutch lining installed in any vehicle registered before 1st April 1995.
Boric acid; Sodium borate	Boric acid or sodium borate in medicinal preparations, cosmetics, toilet preparations and substances being preparations intended for human consumption; Preparations containing boric acid or sodium borate or a combination of both where water or solvent is not the only other part of the composition.
Boron tribromide	
Boron trichloride	
Boron trifluoride	
Bromine; Bromine solutions	
Cadmium-containing silver brazing alloy	
Captafol	
Carbamates	Benomyl; Carbendazim; Chlorpropham; Propham; Thiophanate-methyl; Preparations containing not more than 1%, weight in weight, of propoxur and not containing any other carbamate;

	Preparations containing not more than 1%, weight in weight, of methomyl and not containing any other carbamate.
Carbon monoxide	Gas mixtures containing carbon monoxide weighing less than 1 metric tonne; Gas mixtures containing carbon monoxide as by-products from combustion activities.
Carbon tetrafluoride	
Chlorinated hydrocarbons, the following: Aldrin Benzene hexachloride (BHC) Bromocyclen Camphechlor Chlorbenside Chlorbicyclen Chlordane Chlordecone Chlordimeform Chlorfenethol Chlorfenson Chlorfensulphide Chlorobenzilate Chloropropylate Dicophane (DDT) pp'-DDT Dicofol Dieldrin Endosulfan Endrin Fenazaflor	Paper impregnated with not more than 0.3%, weight in weight, of benzene hexachloride or gamma - BHC provided it is labelled with directions that no food, wrapped or unwrapped, or food utensils are to be placed on the treated paper, and that it is not to be used where food is prepared or served.

Fenson	
Fluorbenzide	
Gamma benzene hexachloride (Gamma - BHC), also known as lindane	
HCH (mixed isomers)	
HEOD [1,2,3,4,10,10-hexachloro-6,7-epoxy-1,4,4a,5,6,7,8,8a- octahydro-1, 4 (exo): 5,8 (endo)-dimethano naphthalene]	
HHDN [1,2,3,4,10,10-hexachloro-1,4,4a,5,8,8a-hexahydro-1,4 (exo):5,8 (endo)-dimethano naphthalene]	
Heptachlor	
Hexachloroethane	
Isobenzan	
Isodrin	
Kelevan	
Methoxychlor [1,1,1-trichloro-2,2-di-(p-methoxyphenyl) ethane]	
Mirex	
Tetrachlordiphenylethane	
[TDE; 1,1-dichloro-2,2-bis (p-chlorophenyl) ethane]	
Tetradifon	
Tetrasul	
Toxaphene	
Allied chlorinated hydrocarbon compounds used as pesticides (insecticides, acaricides, etc.)	
Chlorine	Chlorine used for chlorination of water in swimming pools.
Chlorine trifluoride	
Chlorobenzenes, the following:	
Monochlorobenzene	
Meta-dichlorobenzene	

Ortho-dichlorobenzene	
Trichlorobenzene	
Tetrachlorobenzene	
Pentachlorobenzene	
Hexachlorobenzene	
Chlorophenols, the following:	Substances containing not more than 1%, weight in weight, of chlorophenols.
Monochlorophenol	
Dichlorophenol	
Trichlorophenol	
Tetrachlorophenol	
Pentachlorophenol and its salts and esters	
Chlorophenoxyacids; their salts, esters, amines, which include but are not limited to -	
2,4,5-T and its salts and esters	
Chloropicrin	
Chlorosilanes, the following:	
Hexachlorodisilane	
Phenyltrichlorosilane	
Tetrachlorosilane	
Chlorosulphonic acid	
Chromic acid	Substances containing not more than 9%, weight in weight, of chromic acid; Photographic solutions containing chromic acid in individual containers containing not more than 15 kilograms each of such solutions and of aggregate weight of not more than 500 kilograms of such solutions.
Cyanides	Ferrocyanides; Ferricyanides; Acetonitrile; Acrylonitrile; Butyronitrile; 2-Dimethylaminoacetonitrile;

	Isobutyronitrile; Methacrylonitrile; Propionitrile.
Diborane	
Dibromochloropropane	
Diethyl sulphate	
Dinitro-ortho-cresol (DNOC) and its salts (such as ammonium salt, potassium salt and sodium salt)	
Dinosam; its compounds with a metal or a base	
Dinoseb and its salts and esters, which includes but is not limited to -	
Binapacryl	
Diquat; its salts	
Drazoxolon; its salts	Dressings on seeds.
Dustable powder formulations containing a combination of - Benomyl at or above 7 percent, carbofuran at above 10 percent, thiram at or above 15 percent.	
Endothal; its salts	
Epichlorohydrin	
Ethyl mercaptan	Substances containing less than 1%, weight in weight, of ethyl mercaptan
Ethylene dichloride	
Ethylene imine	
Ethylene oxide	Mixtures of inert gases and ethylene oxide comprising not more than 12%, weight in weight, of ethylene oxide contained in cylinders of water capacity less than 47 litres and for aggregate of not more than 3 numbers of such cylinders.
Ferric chloride	
Fipronil	Formulated products containing Fipronil approved for household use and belonging to the WHO class IV hazards.
Fluorine	
Fluoroacetamide	
Formaldehyde	Substances containing not more than 5%, weight in weight, of formaldehyde; Photographic glazing or hardening solutions.
Formic acid	Substances containing not more than 5%, weight in weight, of formic acid.
Germane	
Hydrazine anhydrous; Hydrazine aqueous solutions	
Hydrochloric acid	Substances containing not more than 9% , weight in weight, of hydrochloric acid.
Hydrofluoric acid	Preparations or solutions containing not more than 2%, weight in weight, of hydrofluoric acid.

Hydrogen chloride	
Hydrogen cyanide; Hydrocyanic acid	Preparations of wild cherry; In reagent kits supplied for medical or veterinary purposes, substances containing less than the equivalent of 0.1%, weight in weight, of hydrocyanic acid.
Hydrogen fluoride	
Hydrogen selenide	
Isocyanates	Polyisocyanates containing less than 0.7%, weight in weight, of free monomeric diisocyanates; Pre-polymerised isocyanates in polyurethane paints and lacquers; Hardeners and bonding agents for immediate use in adhesives.
Lead compounds in paint	Lead compounds in paint in which the lead content is not more than 0.06% by weight of the paint; Lead compounds in paint in which the container is affixed with an appropriate label. The labels to be used for paints containing lead compounds are in accordance with Part IV of the Second Schedule
Lead tetra-ethyl and similar lead containing compounds in petrol intended for use in Singapore as fuel for motor vehicles	
Mercury compounds including inorganic mercury compounds, alkyl mercury compounds, alkyloxyalkyl and aryl mercury compounds, and other organic compounds of mercury	
Mercury and its compounds in batteries	Batteries other than mercury oxide batteries, zinc carbon batteries containing more than 0.001% by weight of mercury per cell and alkaline batteries, except those in button form, containing more than 0.025% by weight of mercury per cell.
Metanil yellow (sodium salt of metanilylazo-diphenylamine)	Dye-indicators used in laboratories
Methyl chloride	
Methyl mercaptan	Substances containing less than 1%, weight in weight, of methyl mercaptan
Monomethyltetrachloro diphenyl methane	
Monomethyl-dichloro-diphenyl methane	
Monomethyl-dibromodiphenyl methane	
Neonicotinoid compounds used as pesticides, the following :	
Imidacloprid	Formulated products containing Imidacloprid approved for household use and belonging to the WHO class IV hazards.
Niclofolan	
Nicotine sulphate	
Nitric acid	Substances containing not more than 9%, weight in weight, of nitric acid.
Nitric oxide	

Nitrobenzene	Substances containing less than 0.1%, weight in weight, of nitrobenzene; Soaps containing less than 1%, weight in weight, of nitrobenzene; Polishes and cleansing agents.
Nitrogen trifluoride	
Ozone depleting substances, namely: (a) Chlorofluorocarbons, the following: Chloroheptafluoropropane Chloropentafluoroethane Chlorotrifluoromethane Dichlorodifluoromethane Dichlorohexafluoropropane Dichlorotetrafluoroethane Heptachlorofluoropropane Hexachlorodifluoropropane Pentachlorofluoroethane Pentachlorotrifluoropropane Tetrachlorodifluoroethane Tetrachlorotetrafluoropropane Trichlorofluoromethane Trichloropentafluoropropane Trichlorotrifluoroethane (b) Halons, the following: Bromochlorodifluoromethane Bromochloromethane Bromotrifluoromethane Dibromotetrafluoroethane (c) Hydrochlorofluorocarbons, the	Products containing any ozone depleting substance other than the following products: (a) in the case of chlorofluorocarbons ? (i) air-conditioners in vehicles registered on or after 1st January 1995 or intended for such vehicles; (ii) equipment for domestic or commercial refrigeration or air-conditioning installed on or after 1st January 1993, or heat pump equipment, which contains any chlorofluorocarbon substance as a refrigerant or in any insulating material of such equipment; (iii) refrigerators that have a compressor rating which exceeds one horsepower; (iv) non-pharmaceutical aerosol products; (v) insulation boards, panels or pipe covers; (vi) polystyrene sheets or finished products; (b) in the case of Halons, portable fire extinguishers; and (c) in the case of bromotrifluoromethane, fire protection systems with building plans approved after 17th June 1991 and installed after 31st December 1991.

following:

1,1-dichloro-1-fluoro-ethane

1,1-dichloro-2,2,3,3,3-pentafluoropropane

1,3-dichloro-1,2,2,3,3-pentafluoropropane

1-chloro-1,1-difluoro-ethane

Chlorodifluoroethane

Chlorodifluoromethane

Chlorodifluoropropane

Chlorofluoroethane

Chlorofluoromethane

Chlorofluoropropane

Chlorohexafluoropropane

Chloropentafluoropropane

Chlorotetrafluoroethane

Chlorotetrafluoropropane

Chlorotrifluoroethane

Chlorotrifluoropropane

Dichlorodifluoroethane

Dichlorodifluoropropane

Dichlorofluoroethane

Dichlorofluoromethane

Dichlorofluoropropane

Dichloropentafluoropropane

Dichlorotetrafluoropropane

Dichlorotrifluoroethane

Dichlorotrifluoropropane	
Hexachlorofluoropropane	
Pentachlorodifluoropropane	
Pentachlorofluoropropane	
Tetrachlorodifluoropropane	
Tetrachlorofluoroethane	
Tetrachlorofluoropropane	
Tetrachlorotrifluoropropane	
Trichlorodifluoroethane	
Trichlorodifluoropropane	
Trichlorofluoroethane	
Trichlorofluoropropane	
Trichlorotetrafluoropropane	
Trichlorotrifluoropropane	
(d) Hydrobromofluorocarbons, the following:	
Bromodifluoroethane	
Bromodifluoromethane	
Bromodifluoropropane	
Bromofluoroethane	
Bromofluoromethane	
Bromofluoropropane	
Bromohexafluoropropane	
Bromopentafluoropropane	
Bromotetrafluoroethane	
Bromotetrafluoropropane	

Bromotrifluoroethane	
Bromotrifluoropropane	
Dibromodifluoroethane	
Dibromodifluoropropane	
Dibromofluoroethane	
Dibromofluoromethane	
Dibromofluoropropane	
Dibromopentafluoropropane	
Dibromotetrafluoropropane	
Dibromotrifluoroethane	
Dibromotrifluoropropane	
Hexabromofluoropropane	
Pentabromodifluoropropane	
Pentabromofluoropropane	
Tetrabromodifluoropropane	
Tetrabromofluoroethane	
Tetrabromofluoropropane	
Tetrabromotrifluoropropane	
Tribromodifluoroethane	
Tribromodifluoropropane	
Tribromofluoroethane	
Tribromofluoropropane	
Tribromotetrafluoropropane	
Tribromotrifluoropropane	
(e) Carbon tetrachloride	
(f) 1,1,1-trichloroethane (methyl	

chloroform)	
(g) Methyl bromide	
Oleum	
Orange II [sodium salt of p-(2-hydroxy-1-naphthylazo) benzenesulphonic acid]	Dye-indicators used in laboratories
Organic peroxides	Car puttys; Substances and preparations containing not more than 3%, weight in weight, of organic peroxides; Solutions of not more than 60%, weight in weight, of methyl ethyl ketone peroxides and total aggregate weight of less than 50 kilograms of such solutions.
Organo-tin compounds, the following: Compounds of fentin Cyhexatin Tributyl tin compounds	
Paraquat; its salts	Preparation in pellet form containing not more than 5%, weight in weight, of salts of paraquat ion.
Perchloromethyl mercaptan	Substances containing less than 1%, weight in weight, of perchloromethyl mercaptan
Perfluorooctane sulfonate (PFOS)	
Phenols, the following: Catechol Cresol Hydroquinone Octyl phenol Phenol Resorcinol	Preparations containing less than 1%, weight in weight, of phenols; Phenols which are intended for the treatment of human ailments and other medical purposes; Soaps for washing; Tar (coal or wood), crude or refined; Photographic solutions containing hydroquinone in individual containers containing not more than 15 kilograms each of such solutions and of aggregate weight of not more than 500 kilograms of such solutions.
Phosgene	
Phosphides	
Phosphine	
Phosphoric acid	Substances containing not more than 50%, weight in weight, of phosphoric acid.
Phosphorus compounds used as pesticides (insecticides, acaricides, etc.), which includes but is not limited to :	Acephate; Bromophos;
Methamidophos	Iodofenphos;
Methyl-parathion	Malathion;
Monocrotophos	Pirimiphos-methyl;
Parathion	Temephos;

Phosphamidon	Tetrachlorvinphos; Trichlorfon; Preparations containing not more than 0.5%, weight in weight, of chlorpyrifos and not containing any other phosphorus compound; Preparations containing not more than 0.5%, weight in weight, of dichlorvos and not containing any other phosphorus compound; Materials impregnated with dichlorvos and not containing any other phosphorus compound for slow release; Preparations containing not more than 1%, weight in weight, of azamethiphos and not containing any other phosphorus compound.
Phosphorus oxybromide	
Phosphorus oxychloride	
Phosphorus pentabromide	
Phosphorus pentachloride	
Phosphorus pentafluoride	
Phosphorus trichloride	
Polybrominated biphenyls	
Polybrominated diphenyl ethers (PBDEs), the following : Penta-brominated diphenyl ether Octa-brominated diphenyl ether Deca-brominated diphenyl ether	
Polychlorinated biphenyls	
Polychlorinated terphenyls	
Potassium hydroxide	Substances containing not more than 17%, weight in weight, of potassium hydroxide; Accumulators; Batteries.
Prochloraz	
Pyrethroid compounds used as pesticides, the following : Fenvalerate	Formulated products containing Fenvalerate approved for household use and belonging to the WHO Class IV hazards.
Sodium azide	Air bag devices in motor vehicles
Sodium hydroxide	Substances containing not more than 17%, weight in weight, of sodium hydroxide; Made-up formulated preparations either liquid or solid for biochemical tests.
Sulphur in diesel intended for use in Singapore as fuel for motor vehicles or industrial plants	Sulphur in diesel in which the sulphur content is 0.005% or less by weight.
Sulphur tetrafluoride	
Sulphur trioxide	

Sulphuric acid	Substances containing not more than 9%, weight in weight, of sulphuric acid; Accumulators; Batteries; Fire extinguishers; Photographic developers containing not more than 20%, weight in weight, of sulphuric acid.
Sulphuryl chloride	
Sulphuryl fluoride	
Tetraethyl lead, tetramethyl lead and similar lead containing compounds	
Thallium; its salts	
Titanium tetrachloride	
Tris (2, 3-dibromo-1-propyl) phosphate	
Tungsten hexafluoride	

Part II - General Exemptions

Adhesives;

Anti-fouling compositions;

Anti-fouling compositions other than those containing tributyl tin compounds as defined in this List;

Builders' materials other than those containing asbestos as defined in this List;

Ceramics;

Distempers;

Electrical valves;

Enamels;

Explosives;

Fillers;

Fireworks;

Fluorescent lamps;

Glazes;

Glue;

Inks;

Lacquer solvents;

Loading materials;

Matches;

Motor fuels and lubricants except diesel oil and petrol;

Paints other than paints containing mercury compounds, paints containing lead compounds and paints containing asbestos as defined in this List;

[Pharmaceutical Aerosols](#)

Photographic paper;

Pigments other than those containing tributyl tin compounds as defined in this List;

Plastics;

Propellants [other than those containing ozone depleting substances](#);

Rubber;

Varnishes;

Vascular plants and their seeds.

APPENDIX 8

HAZARDOUS SUBSTANCES – QUANTITIES EXCEEDING WHICH TRANSPORT APPROVAL IS REQUIRED

Substance	Qty (kgs)
1,2-dibromoethane (EDB)	0
Acetyl bromide	0
Allyl isothiocyanate	0
Acetic acid	1000
Ammonia (35% or greater)	500
Ammonia (less than 35%)	1000
Antimony pentachloride	50
Antimony trihydride	0
Arsine	0
Arsenical Substances	50
Boric Acid; Sodium borate	5000
Boron tribromide	0
Boron trichloride	50
Boron trifluoride	50
Bromine, bromine solutions	50
Captafol	0
Carbamates except bendiocarb, BPMC (fenobucarb), mercaptodimethur (methiocarb)	0
Carbon monoxide	1000
Carbon tetrafluoride	500
Chlorine	500
Chlorine trifluoride	50
Chlorinated hydrocarbon compounds used as pesticides	0
Chlorobenzenes	0
Chlorophenols	0
Chlorophenoxyacids; their salts, esters, amines	0
Chlorosilanes	50
Chlorosulphonic acid	50
Chromic acid	50
Cyanides	50
Diborane	50
Dibromochloropropane	50
Diethyl sulphate	500
Epichlorohydrin	50
Ethyl mercaptan	50
Ethylene dichloride	0
Ethylene imine	0
Ethylene oxide	50
Ferric chloride	1000

Fipronil	5000
Fluorine	0
Fluoroacetamide	0
Formic acid	1000
Germane	0
Hydrazine anhydrous, hydrazine aqueous solutions	50
Hydrochloric acid	1000
Hydrocyanic acid; Hydrogen cyanide	0
Hydrofluoric acid	500
Hydrogen chloride	500
Hydrogen selenide	0
Isocyanates	500
Lead tetra-ethyl and similar lead containing compounds in petrol intending for use in Singapore as a fuel for motor vehicles	0
Mercury compounds including inorganic mercury compounds, alkyl mercury compounds, alkyloxyalkyl and aryl mercury compounds, and other organic compounds of mercury	0
Metanil yellow (sodium salt of metanilylazo-diphenylamine)	5000
Methyl bromide	50
Methyl chloride	50
Methyl mercaptan	50
Monomethyltetrachloro diphenyl methane	0
Monomethyl-dichloro-diphenyl methane	0
Monomethyl-dibromo-diphenyl methane	0
Neonicotinoid compounds used as pesticides	5000
Nitric acid (95% or greater)	50
Nitric acid (less than 95%)	1000
Nitric oxide	0
Nitrogen trifluoride	50
Oleum	50
Orange II (sodium salt of p-(2-hydroxy-1 naphthylazo) benzenesulphonic acid)	5000
Organic peroxides	500
Organo-tin compounds	0
Perchloro methyl mercaptan	50
Perfluorooctane sulfonate (PFOS)	0
Phenols	500
Phosgene	0
Phosphides	0
Phosphine	0
Phosphorous compounds except dimethoate, fenchlorophos, fenitrothion, Phenthoate, profenophos, Prothiophos, quinalphos	0
Phosphorus oxybromide	0
Phosphorus oxychloride	50
Phosphorus pentabromide	0
Phosphorus pentachloride	50

Phosphorus pentafluoride	50
Phosphorus trichloride	50
Polybrominated biphenyls	0
Polybrominated diphenyl ethers (PBDEs)	0
Polychlorinated biphenyls	0
Polychlorinated terphenyls	0
Potassium hydroxide	1000
Prochloraz	0
Pyrethroid compounds used as pesticides	5000
Sodium azide	0
Sodium hydroxide	1000
Sulphur in diesel intended for use in Singapore as fuel for motor vehicles or industrial plants	0
Sulphur tetrafluoride	0
Sulphur trioxide	50
Sulphuric acid	1000
Sulphuryl chloride	0
Sulphuryl fluoride	0
Tetraethyl lead, tetramethyl lead and similar lead containing compounds	0
Titanium tetrachloride	1000
Tris(2,3-dibromopropyl) phosphate	0
Tungsten hexafluoride	0

APPENDIX 9

ALLOWABLE LIMITS FOR TRADE EFFLUENT DISCHARGED INTO A PUBLIC SEWER/WATERCOURSE/CONTROLLED WATERCOURSE

	Items Of Analysis	Public Sewer	Watercourse	Controlled Watercourse
		(Units in milligram per litre or otherwise stated)		
1	Temperature of discharge	Please refer to PUB's web page	45 °C	45 °C
2	Colour		7 Lovibond Units	7 Lovibond Units
3	pH Value		6 - 9	6 - 9
4	BOD (5 days at 20°C)		50	20
5	COD		100	60
6	Total Suspended Solids		50	30
7	Total Dissolved Solids		-	1000
8	Chloride (as chloride ion)		-	250
9	Sulphate (as SO ₄)		-	200
10	Sulphide (as sulphur)		0.2	0.2
11	Cyanide (as CN)		0.1	0.1
12	Detergents (linear alkylate sulphonate as methylene blue active substances)		15	5
13	Grease and Oil		10 (Total) 10(Hydrocarbons)	1 (Total)
14	Arsenic		0.1	0.01
15	Barium		2	1
16	Tin		-	5
17	Iron (as Fe)		10	1
18	Beryllium		-	0.5
19	Boron		5	0.5
20	Manganese		5	0.5
21	Phenolic Compounds (expressed as phenol)		0.2	Nil
22	*Cadmium		0.1	0.003

23	*Chromium (trivalent and hexavalent)		1	0.05
24	*Copper		0.1	0.1
25	*Lead		0.1	0.1
26	*Mercury		0.05	0.001
27	*Nickel		1	0.1
28	*Selenium		0.5	0.01
29	*Silver		0.1	0.1
30	*Zinc		1	0.5
31	*Metals in Total		1	0.5
32	Chlorine (Free)		1	1
33	Phosphate (as PO ₄)		5	2
34	Calcium (as Ca)		-	150
35	Magnesium (as Mg)		-	150
36	Nitrate (as NO ₃)		-	20

NOTE: * Where 2 or more of the metals listed in the table are present in the trade effluent, the total concentration of the metals shall not exceed 1 and 0.5 milligrams per litre for discharge into a watercourse and a controlled watercourse respectively.

“Controlled Watercourse” means a watercourse from which potable water supplied by PUB under the Public Utilities Act is obtained but does not include a watercourse from which water is pumped into a main of the PUB.

The trade effluent discharged into any watercourse shall not contain any of the following substances:-

- (1) radioactive material;
- (2) any pesticide, fungicide, herbicide, insecticide, rodenticide or fumigant;
- (3) refuse, garbage, sawdust, timber, human or animal waste or solid matter;
- (4) petroleum or other inflammable solvent; or
- (5) a substance that either by itself or in combination or by reaction with other waste or refuse may give rise to any gas, fume, or odour or substance which is or is likely to be a hazard to human life, a public nuisance, injurious or otherwise objectionable.

The trade effluent shall be analysed in accordance with the latest edition of 'Standard Methods for the Examination of Water and Wastewater' published jointly by the American Water Works Association and the Water Pollution Control Federation of the United States.

APPENDIX 10

TRADE EFFLUENT TARIFF SCHEME

The scale of fee to be levied for the discharge of biodegradable trade effluent into a public sewer is as follows:-

Concentration (mg/l)	Fee at \$ per cubic metre or part thereof	
	BOD	TSS
400 - 600	0.21	0.15
601 - 800	0.42	0.30
801 - 1000	0.63	0.45
1001 - 1200	0.84	0.60
1201 - 1400	1.05	0.75
1401 - 1600	1.26	0.90
1601 - 1800	1.47	1.05
1801 - 2000	1.68	1.20
2001 - 2200	1.89	1.35
2201 - 2400	2.10	1.50
2401 - 2600	2.31	1.65
2601 - 2800	2.52	1.80
2801 - 3000	2.73	1.95
3001 - 3200	2.94	2.10
3201 - 3400	3.15	2.25
3401 - 3600	3.36	2.40
3601 - 3800	3.57	2.55
3801 - 4000	3.78	2.70

NB: BOD = Biochemical Oxygen Demand (5 days at 20°C)

TSS = Total Suspended Solids

Trade effluent containing BOD or TSS greater than 4000 mg/l shall be treated to the required limit prior to discharge into a public sewer.

Prior approval is required to dispose of organic sludge at a designated Water Reclamation Plants/Sludge Treatment Works on the payment of a fee at a rate of \$7.00 per cubic meter or part thereof. Organic sludge means the organic matter in trade effluent which has a minimum solid content of 97 per cent by weight.

APPENDIX 11

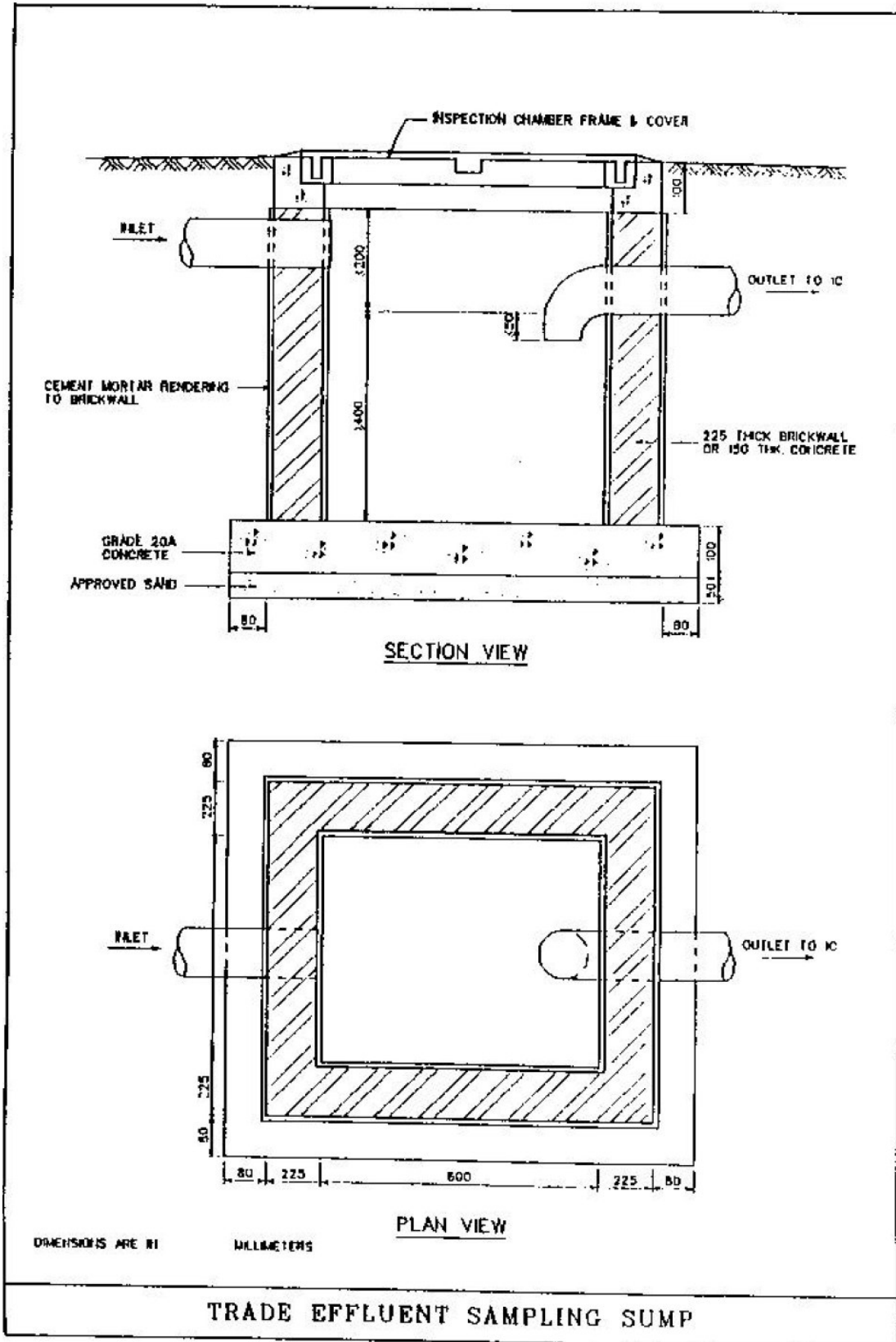

APPENDIX 12

REQUIREMENTS ON CONTINUOUS ON-LINE pH MONITORING AND EFFLUENT DISCHARGE CONTROL AT LAST INSPECTION CHAMBER OF FACTORY

- 1 Continuous pH monitoring and effluent discharge control shall be carried out at the last inspection chamber before the discharge enters a public sewer.
- 2 A concrete hump of not more than 50mm (vertical height) shall be constructed across the flow channel of the last inspection chamber to maintain effluent in the channel when there is no effluent discharge.
- 3 A chemical resistant pH probe (range of 0-14) shall be installed in the channel upstream of the hump. The pH probe shall detect/monitor the pH value of the discharge. The probe shall be positioned firmly such that the tip of the probe is constantly in contact with the liquid in the channel. It shall also be easily lifted out of the chamber and repositioned back without the need to go down the chamber. [An auto flushing system using water or compressed air shall be provided to prevent any fouling or clogging of the sensor of the pH probe.](#)
- 4 The cable of the pH probe shall be laid in a heavy duty PVC conduit. The mountings for the pH probe inside the last inspection chamber shall be of corrosion resistant materials.
- 5 A pH recorder chart (range of 0-14) shall be provided to record the pH value detected as well as to record the 'open' and 'close' position of the penstock. The pH value shall be recorded on a chart which can be continuously operated for a month.
- 6 A penstock with an electrically operated actuator shall be installed at the inlet to the last inspection chamber. If a pneumatic actuator is used, the air/gas supply shall be tapped from a cylinder. The actuator shall be linked to a pH controller and the record chart. A limit switch to indicate the 'open' or 'close' position of the penstock shall be incorporated. The switch shall be linked directly to the recorder chart. The setting of the actuator shall be such that the penstock remains open as long as the pH value varies within the allowable limit of 6 to 9. Exceeding the limit, the pH controller shall activate the actuator to close the penstock.
- 7 The pH meter, recorder with alarm and penstock actuator shall be operated either on AC or DC supply. However, the system should incorporate a power back-up such that during power failure/interruption, the back-up shall continue to operate the pH meter and recorder for a period of 5 hours and the actuator (if necessary). During normal operation, power shall be supplied from the AC main to operate the monitoring instrument and charge the power pack simultaneously.
- 8 An instrument panel (weather-proof) shall be provided to house:-
 - (a) pH meter cum controller (range of 0 - 14).
 - (b) pH chart recorder (range of 0 - 14).

- (c) alarm - audible type.
 - (d) power pack (rechargeable batteries).
 - (e) AC/DC converter.
 - (f) Air/gas cylinder, if any.
 - (g) Resetting switch/button for the actuation of the penstock.
- 9 The door of the instrument panel shall be provided with a glass or plastic window for viewing the pH recorder chart.
- 10 Wherever appropriate the instrument panel shall be located near or within the guard-house.
- 11 Means to seal the instrument panel and the last inspection chamber cover shall be provided. PCD will seal the instrument panel and the last inspection chamber. The seal will be broken when the instrument panel or inspection chamber is opened.
- 12 The instrument panel and the last inspection chamber shall not be opened without PCD's approval. PCD will replace the seal after each occasion when the instrument panel or inspection chamber has been opened.
- 13 Details of the monitoring and control system shall be submitted to PCD before installation.

NOTES:

- 1 The factory is responsible for the proper maintenance of the system which include regular cleaning and calibration of the pH probe.
- 2 Failure to discharge the effluent within the allowable limit at all times will render the factory liable to prosecution under the Sewerage and Drainage(Trade Effluent) Regulations, 1999.
- 3 The pH recorder chart shall be endorsed by the factory before it is submitted to PCD for checking on a monthly basis.
- 4 The above system will ensure that only properly neutralised effluent is discharged to a public sewer. This is to protect the sewerage system from being damaged by corrosive discharge.
- 5 In order to prevent inconvenience caused by the shutting of the penstock (due to undesirable pH level), factories may consider providing effluent recycling facilities to accommodate any unforeseen event.

APPENDIX 13

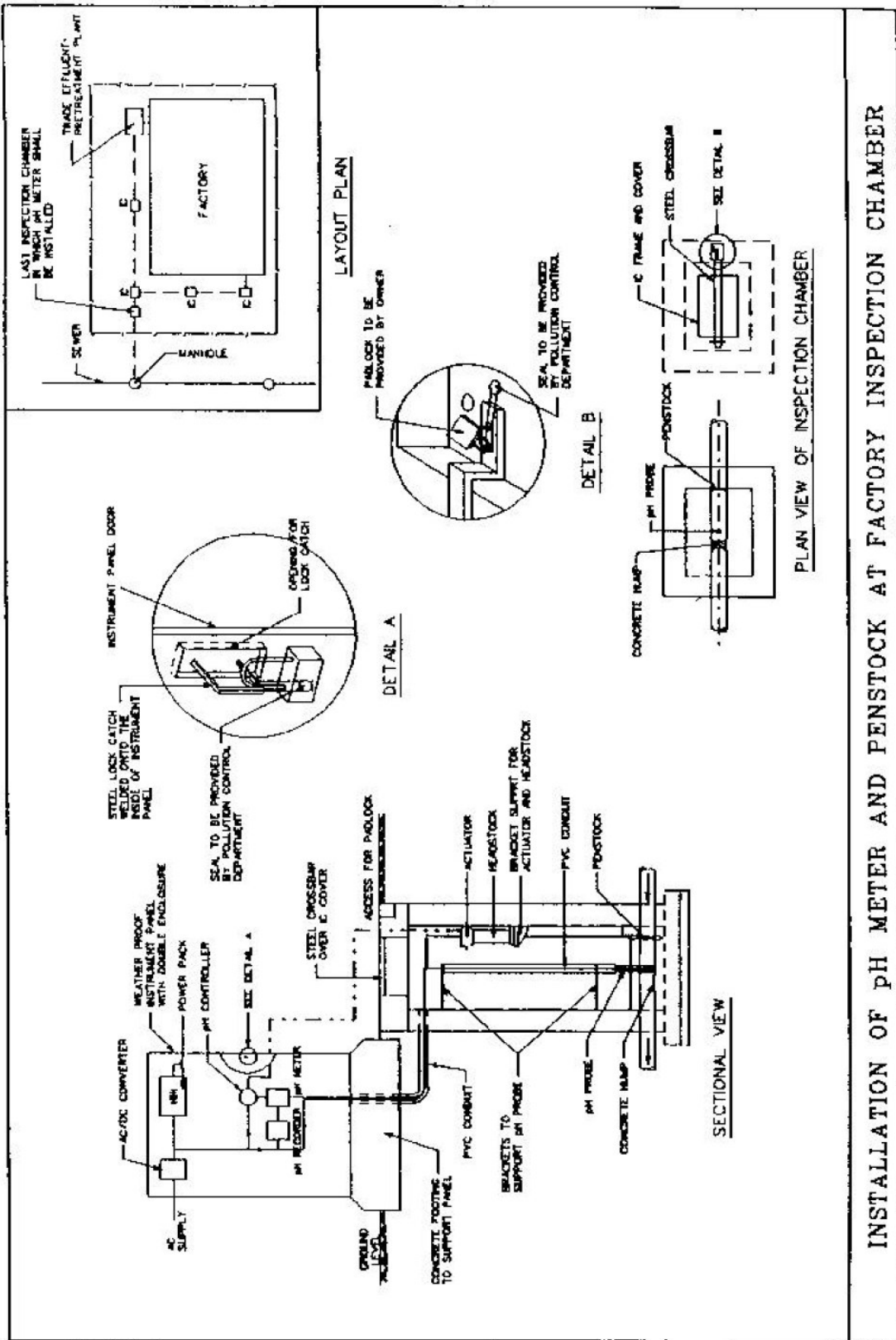

APPENDIX 14

GUIDELINES FOR LEAK TEST

A leak test shall be conducted before an underground tank is put into use. The leak test shall conform to the following guidelines:-

- The leak test method shall be able to measure a leak rate of at least 0.19 litre per hour, and be capable of testing the entire tank system, including piping.
- If the tank has a loss rate in excess of 0.19 litre per hour, the tank shall be considered to be leaking.
- The leak tests shall be carried out in accordance with an established leak test method and certified by professional engineers. The test results shall be submitted to PCD.

APPENDIX 15





















GUIDELINES FOR CONTINGENCY PLAN

A contingency plan to deal with leaks from underground tanks shall be submitted to PCD. The contingency plan shall include the following :-

- To appoint a competent party or person to deal with leaks from underground tanks.
- To set up guidelines to activate the contingency plan (ie. who, when and how to contact emergency coordinator, confirmation of leak, etc).
- To inform PCD as soon as leak is detected. FSB shall also be informed if the chemical/product is flammable or combustible.
- To remove chemical/product from the tank to a temporary storage by the competent party or person.
- To remove the tank for inspection.
- To remove the contaminated soil for proper disposal.
- To carry out soil testing to ensure that all the pollutants have been removed.
- To repair or replace the tank and re-construct the secondary containment chamber if necessary.

APPENDIX 16







RECOMMENDATION OF STORAGE OF HAZARDOUS SUBSTANCES

		Fe	Ex	Fh	Gh	Fa	Tx	Ra	Gp	Ox	Xn
											
Fe		+	-	-	-	-	0	-	-	-	0
Ex		-	+	-	-	-	-	-	-	-	-
Fh		-	-	+	0	-	0	-	-	-	0
Gh		-	-	0	+	-	0	-	-	-	0
Fa		-	-	-	-	+	-	-	-	-	0
Tx		0	-	0	0	-	+	-	0	0	0
Ra		-	-	-	-	-	-	+	-	-	-
Gp		-	-	-	-	-	0	-	+	0	0
Ox		-	-	-	-	-	0	-	0	+	0
Xn		0	-	0	0	0	0	-	0	0	+





- Joint storage not allowed.
- 0 Joint storage allowed under observation of specific precautions.
- + Joint storage allowed.

CLASSIFICATION OF SUBSTANCES

Fire Hazard Categories

Symbol	SS* 288	Description
 Fe	Class 4	Combustible substances
 Fa	Class 4.2	Substances liable to spontaneous combustion
 Fh	Class 4.3	Substances which give off combustible gases on contact with water
 Gp	Class 2	Combustible and non-combustible gases under pressure incl. aerosol cans
 Ox	Class 5	Substances acting as oxidizing agents or sources of oxygen
 Ex	Class 1	Explosives substances

Personal Hazard Categories

 Tx	Class 6	Substances which can cause death or serious damage to health
 Gh	Class 6	Substances which give off poisonous or foul smelling gases on contact with water
 Xn	Class 8	Substances which are a health hazard (incl. irritating and corrosive substances)
 Ra	Class 7	Radioactive substances

SS* : Singapore Standards

APPENDIX 17

**RETENTION BASIN FOR FIRE-FIGHTING WATER FOR WAREHOUSE
STORING HAZARDOUS SUBSTANCES**

Fire Compartment (m ²)	Average Fire-Fighting Water Used (l/m ² min)	Retention Of Fire-Fighting Water (m ³ /m ²)	Total Volume of Retention Required (m ³)
50	WO WS With WS	3.3 3.3	5 5
100	WO WS With WS	6.6 6.6	20 20
150	WO WS With WS	8.8 8.8	60 60
200	WO WS With WS	10.0 10.0	120 120
300	WO WS With WS	7.7 6.6	210 120
400	WO WS With WS	6.6 5.0	320 120
500	WO WS With WS	6.0 4.0	450 120
600	WO WS With WS	5.8 3.3	600 120
800	WO WS With WS	5.6 2.5	960 120
1000	WO WS With WS	5.4 2.0	1400 120
1200	WO WS With WS	5.2 1.7	1800 120
1600	WO WS With WS	5.0 1.3	2400 120
>1600	WO WS With WS	5.0 1.3	To Be Calculated 120

WO WS = Without Water Sprinklers.

With WS = With Water Sprinklers.

NOTE: The retention volume does not include materials leaked out from containers and rainwater.

APPENDIX 18

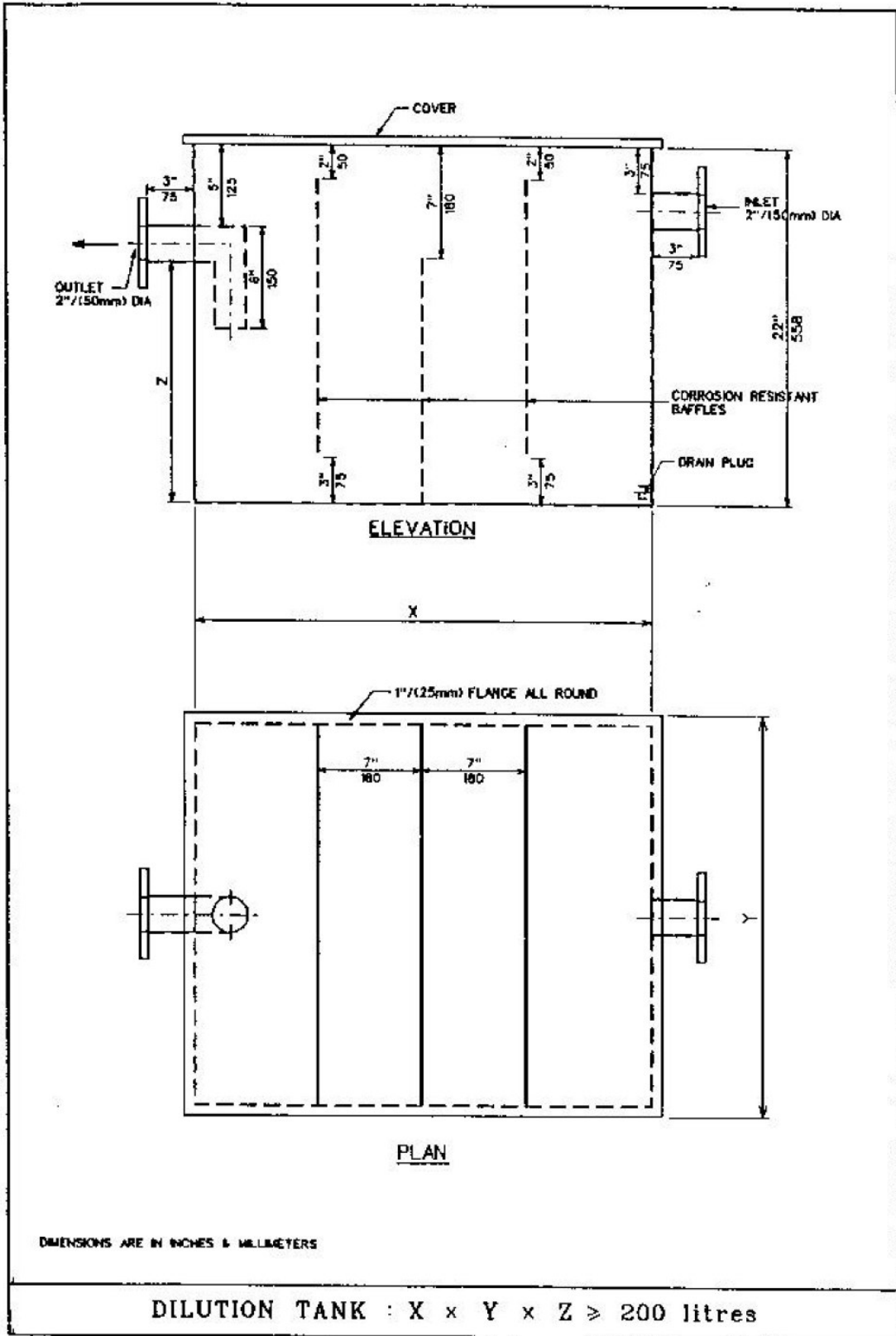

APPENDIX 19

STANDARDS OF CONCENTRATION OF AIR IMPURITIES

Substance	Trade, industry, process, fuel burning equipment or industrial plant	Emission limits
(a) Ammonia and ammonium compounds	Any trade, industry or process	76 mg/Nm ³ expressed as ammonia
(b) Antimony and its compounds	Any trade, industry or process	5 mg/Nm ³ expressed as antimony
(c) Arsenic and its compounds	Any trade, industry or process	1 mg/Nm ³ expressed as arsenic
(d) Benzene	Any trade, industry or process	5 mg/Nm ³
(e) Cadmium and its compounds	Any trade, industry or process	3 mg/Nm ³ expressed as cadmium
(f) Carbon monoxide	Any trade, industry, process or fuel burning process	625 mg/Nm ³
(g) Chlorine	Any trade, industry or process	32 mg/Nm ³
(h) Copper and its compounds	Any trade, industry or process	5 mg/Nm ³ expressed as copper
(i) Dioxins and furans	Any waste incinerator	i 1.0 ng TEQ/Nm ³ for waste incinerators commissioned before 1st Jan 2001 ii 0.1 ng TEQ/Nm ³ for waste incinerators commissioned on or after 1st Jan 2001
(j) Ethylene oxide	Any trade, industry or process	5 mg/Nm ³
(k) Fluorine, hydrofluoric acid or inorganic fluorine compounds	Any trade, industry or process	50 mg/Nm ³ expressed as hydrofluoric acid
(l) Formaldehyde	Any trade, industry or process	20 mg/Nm ³
(m) Hydrogen chloride	Any trade, industry or process	200 mg/Nm ³
(n) Hydrogen sulphide	Any trade, industry or process	7.6 mg/Nm ³
(o) Lead and its compounds	Any trade, industry or process	5 mg/Nm ³ expressed as lead
(p) Mercury and its compounds	Any trade, industry or process	3 mg/Nm ³ expressed as mercury
(q) Oxides of nitrogen	Any trade, industry, process or fuel burning equipment	700 mg/Nm ³ expressed as nitrogen dioxide
(r) Particulate substances including smoke, soot, dust, ash, fly-ash, cinders, cement, lime, alumina, grit and other	Any trade, industry, process, fuel burning equipment or industrial plant (except for any cold blast foundry cupolas)	i 100 mg/Nm ^{3*} ; or ii where there is more than one flue, duct or chimney in any schedules premises, the total mass of the

Substance	Trade, industry, process, fuel burning equipment or industrial plant	Emission limits
solid particles of any kind		particulate emissions from all of such flue, duct or chimney divided by the total volume of such emissions shall not exceed 100 mg/Nm ³ and the particulate emissions from each of such flue, duct or chimney shall not exceed 200 mg/Nm ³ at any point in time.
(s) Smoke	All stationary fuel-burning sources	Ringelmann No. 1 or equivalent opacity (Not to exceed more than 5 minutes in any period of one hour)
(t) Styrene monomer	Any trade, industry or process	100 mg/Nm ³
(u) Sulphur dioxide (non-combustion sources)	Any trade, industry or process	500 mg/Nm ³
(v) Sulphur trioxide and other acid gases	The manufacture of sulphuric acid	500 mg/Nm ³ expressed as sulphur trioxide Effluent gases shall be free from persistent mist.
(w) Sulphur trioxide or Sulphuric acid mist	Any trade, industry or process, other than any combustion process and any plant involving the manufacture of sulphuric acid	100 mg/Nm ³ expressed as sulphur trioxide
(x) Vinyl chloride monomer	Any trade, industry or process	20 mg/Nm ³

Note: The concentration of any substance specified in the first column emitted from any operation in any trade, industry, process, fuel burning equipment or industrial plant specified in the second column shall not at any point before admixture with air, smoke or other gases, exceed the limits specified in the third column.

“dioxins and furans” means polychlorinated dibenzo-p-dioxins (PCDD) and polychlorinated dibenzofurans (PCDF), being tricyclic and aromatic compounds formed by 2 benzene rings which are connected by 2 oxygen atoms in PCDD and by one oxygen atom in PCDF and the hydrogen atoms of which may be replaced by up to 8 chlorine atoms;

“mg” means milligram;

“ng” means nanogram;

“Nm³” means normal cubic metre, being that amount of gas which when dry, occupies a cubic metre at a temperature of 0 degree Centigrade and at an absolute pressure of 760 millimetres of mercury;

“TEF” means Toxic Equivalency Factor;

“TEQ” means Toxic Equivalent, being the sum total of the concentrations of each of the dioxin and furan compounds specified in the first column of the table below multiplied by their corresponding TEF specified in the second column thereof:

Dioxin/Furan	TEF
2,3,7,8-Tetrachlorodibenzo-p-dioxin	1
1,2,3,7,8-Pentachlorodibenzo-p-dioxin	1
1,2,3,4,7,8-Hexachlorodibenzo-p-dioxin	0.1
1,2,3,6,7,8-Hexachlorodibenzo-p-dioxin	0.1
1,2,3,7,8,9-Hexachlorodibenzo-p-dioxin	0.1

1,2,3,4,6,7,8-Heptachlorodibenzo-p-dioxin	0.01
Octachlorodibenzo-p-dioxin	0.0001
2,3,7,8-Tetrachlorodibenzofuran	0.1
1,2,3,7,8-Pentachlorodibenzofuran	0.05
2,3,4,7,8-Pentachlorodibenzofuran	0.5
1,2,3,4,7,8-Hexachlorodibenzofuran	0.1
1,2,3,6,7,8-Hexachlorodibenzofuran	0.1
1,2,3,7,8,9-Hexachlorodibenzofuran	0.1
2,3,4,6,7,8-Hexachlorodibenzofuran	0.1
1,2,3,4,6,7,8-Heptachlorodibenzofuran	0.01
1,2,3,4,7,8,9-Heptachlorodibenzofuran	0.01
Octachlorodibenzofuran	0.0001

APPENDIX 20

BOUNDARY NOISE LIMITS FOR FACTORY PREMISES

The maximum permitted boundary noise levels are as follows:

Type of affected premises	Maximum permitted noise level (reckoned as the equivalent continuous noise level over the specified period) in decibels (dBA)		
	Day 7 am - 7 pm	Evening 7 pm - 11 pm	Night 11 pm - 7 am
Noise Sensitive Premises	60	55	50
Residential Premises	65	60	55
Commercial Premises	70	65	60

Type of affected premises	Maximum permitted noise level (reckoned as the equivalent continuous noise level over 5 minutes) in decibels (dBA)		
	Day 7 am - 7 pm	Evening 7 pm - 11 pm	Night 11 pm - 7 am
Noise Sensitive Premises	65	60	55
Residential Premises	70	65	60
Commercial Premises	75	70	65
Factory Premises	75	70	65

APPENDIX 21

Pollutive Activities Subject To Site Assessment Before Change of Use Or Rezoning

- a) Oil installations and other premises storing, handling and using large quantities of oils and similar hydrocarbons products, including the following:
 - Oil refineries;
 - Oil depots;
 - Petrochemical complexes;
 - Petrol stations and refueling depots;
 - Aircraft manufacture and repair industries;
 - Motor repair workshops.

- b) Chemical plants, chemical warehouses or terminals including the following:
 - Chemical warehouses or terminals;
 - Pharmaceutical/biomedical plants;
 - Pesticides formulation factories;
 - Wood treatment and preservation facilities;
 - Large electroplating works;
 - Factories that use, manufacture or store toxic chemicals.

- c) Shipyards and grit blasting works

- d) Gas works

- e) Power stations

- f) Toxic wastes treatment facilities

- g) Scrap yards

- h) Landfill site for municipal or industrial wastes

- i) Facilities for the treatment of sewage.