

APEC Regional Workshop on Single Window



AKMAL
Melaka, Malaysia
16th to 19th October 2012

Malaysia Experiences

By
Zahari Azar Zainudin
Director of National Single Window
Dagang Net Technologies Sdn Bhd

Contents



Introduction



Malaysia Experiences



Challenges

Dagang Net Shareholding Structure - GLC

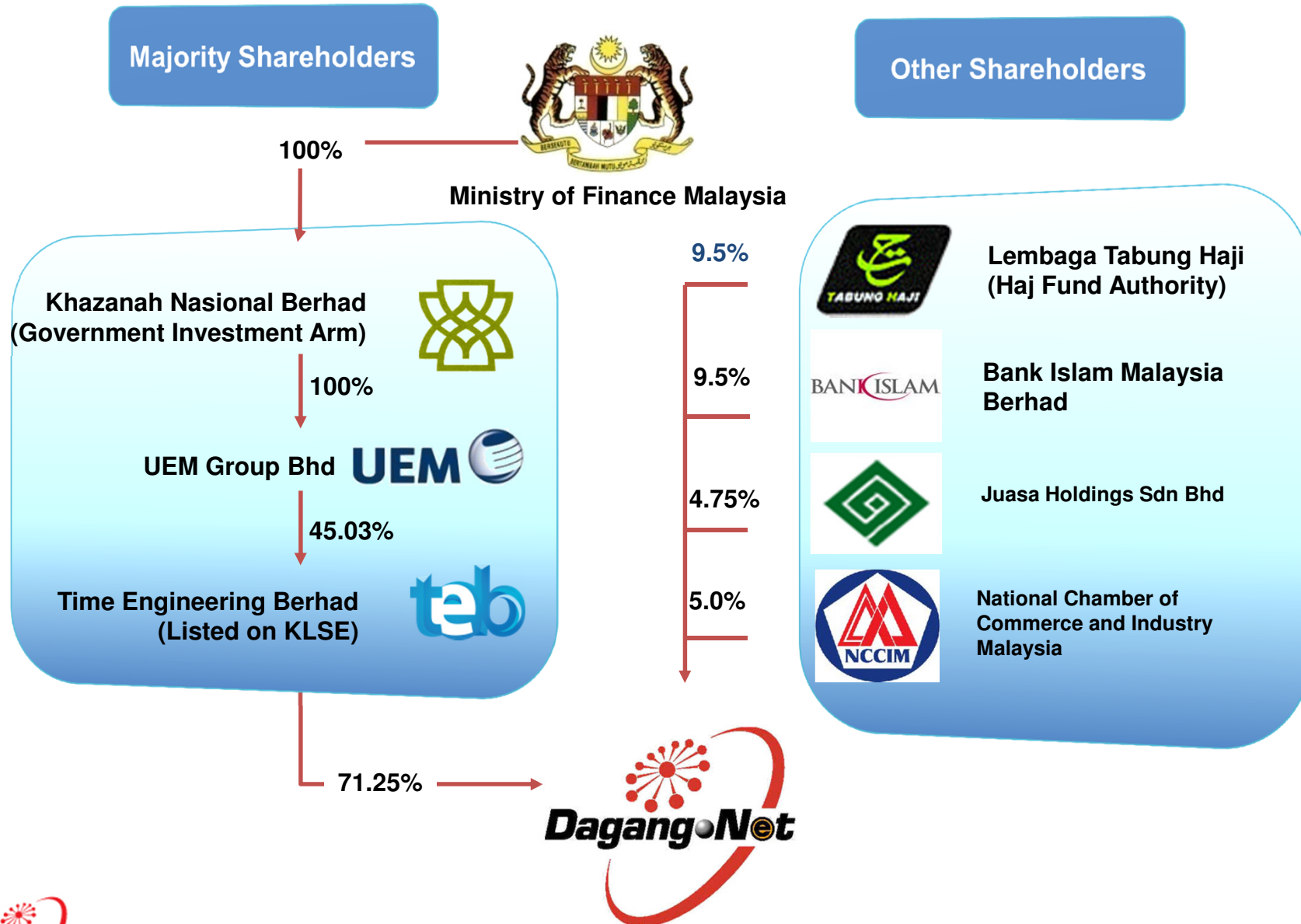

Corporate Overview



**Incorporated
in 1989**



**Trade
Facilitation**



**Government-
Linked
Company**



**Malaysia's
National
Single
Window**

Value Proposition



**Trade Facilitation
Pioneer**

**E-Commerce
Community Builder**

**Project
Management**



**State-of-the-Art
Facilities**

**Integrated Intelligent
Infrastructure**

**Certified ISO/IEC
27001:2005**



**Message & Standard
Development**

**National ICT Strategic
Consultancy**

**Private-Public
Collaboration**

Community Building Experience

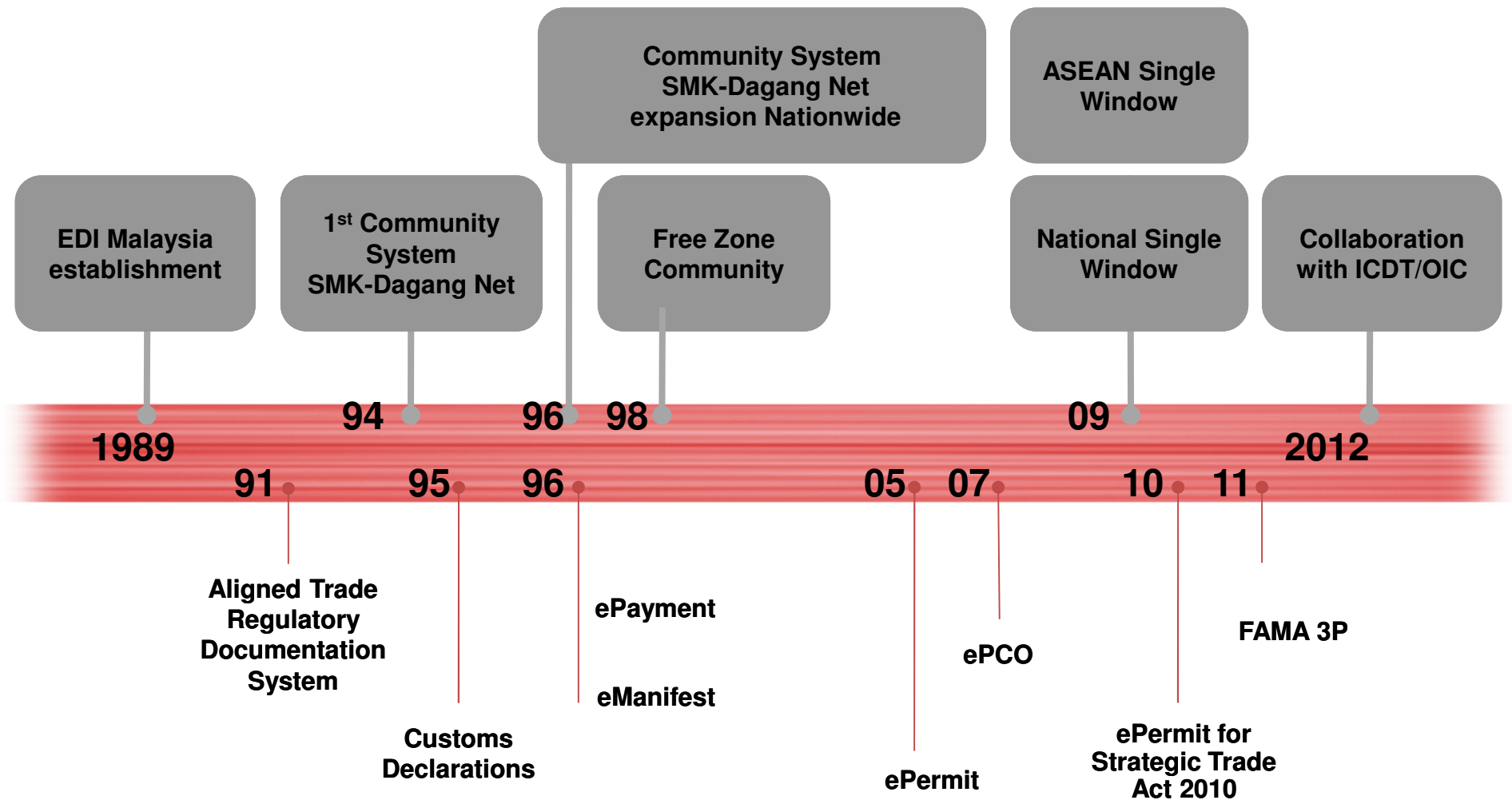

Strategic Partnership Values



Contribution's

- Advisory & Consultancy
 - Trade Facilitation, Customs & Single Window related
 - National Network Business & Operations
 - Operations Strategies, Framework, Policies & Procedures
 - Integration, Interoperability Framework & Guidelines
 - Business Process Re-Engineering
 - Business Strategies & Modeling
- Design & Implementation
 - National Infrastructure/Network
 - Infrastructure/Network Security & Policy
 - Integration & Interoperability
- Users Facilitation
- Education & Marketing
- Project Management
- Cross-Border Exchange



National Single Window



myTRADELINK
MALAYSIA NATIONAL SINGLE WINDOW

National Single Window

A one-stop trade facilitation system linking relevant governments and trading communities and also other various businesses involved in global trade and logistics

ENGLISH | BAHASA MALAYSIA

myTRADELINK
MALAYSIA NATIONAL SINGLE WINDOW | The Official Portal for Trade Facilitation

Call Us 1300 133 133
MONDAY, 18 JUNE, 2012

HOME ABOUT MYTRADELINK INFORMATION TRADE REPOSITORY FEEDBACK ARCHIVE FAQ

Sign On
NOT A SUBSCRIBER?

Search...

Announcement

FAMA ePermit system - Enhanced with Quota Module
FAMA ePermit system has been enhanced with a new quota module effective 1 May 2012. Applicants can now directly access their quota details from the system. Letter from FAMA

READ MORE

Welcome to myTRADELINK

THE ONE-STOP POINT FOR EXCHANGING TRADE DOCUMENTATION

myTRADELINK portal connects the public and private sectors of the trade and logistics community through single connectivity access for safe, secure and efficient exchange of electronic trade documents. An initiative of the Malaysian Government, led by the Ministry of Finance (MOF) and operated by Dagang Net Technologies Sdn Bhd, myTRADELINK facilitates and expedites the smooth flow of information for goods being imported, exported or in transit.

READ MORE

NSW - Transaction Statistics

May 2012

Category	No of Messages
Customs Declarations	955k
Manifest Declarations	603k
Duty Payment	20k
ePermit applications	44k
ePCO applications	27k
ePermitSTA	296

Definition: UN/CEFACT Recommendation 33

“A facility that allows parties in trade and transport to lodge standardized information and documents through a single entry point to fulfill all imports, exports and transit-related regulatory requirements. If information in electronic, then, individual data elements should only be key in once.”

www.mytradelink.gov.my



Malaysia NSW - Current Environment

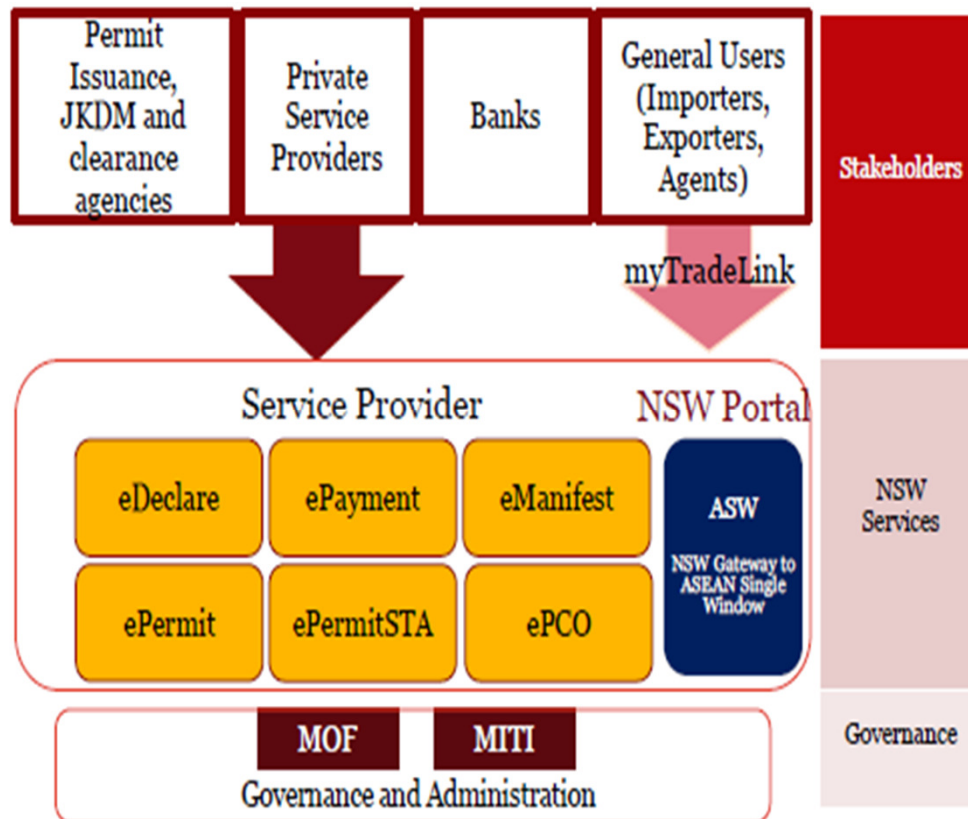

- ✓ Design, Develop, Operate & Maintain by Dagang Net Technologies Sdn Bhd (DNT)
- ✓ The system and infrastructure which hosts the NSW are owned by DNT
- ✓ Trade Data is owned by the Government
- ✓ The Government's role is to provide an oversight, governance and control over the NSW
- ✓ The rates for the fees and charges are in accordance to the agreement signed between service provider and the Malaysian Government

National Single Window Services

A one-stop trade facilitation system linking relevant governments and trading communities and also other various businesses involved in global trade and logistics.

eManifest™



Shipping community system facilitate submission of **manifest** from the port users to the respective authorities

eDeclare™



Customs declaration system that facilitates the preparation and submission of **customs declarations**

ePCO™



Certificate of origin application and approval system that **certifies the country of origin** of a particular product

ePayment™



Duty payment service that enables preparation and submission of **duty payment** to Customs.

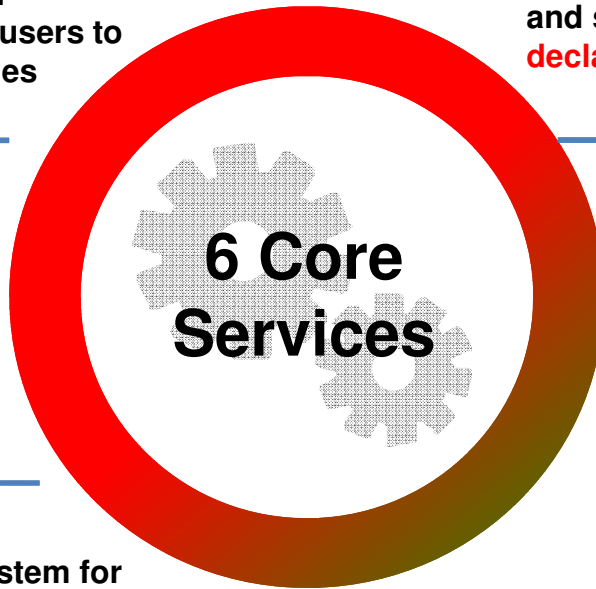

ePermitSTA



Permit application system for **Strategic Trade Act 2010 (STA 2010)** that enables **application and approval of pre-registration and permits** under the purview of the STA 2010

ePermit™



Import, export & transshipment **permit applications system** to relevant Permit Issuing Agencies

Corporate Fast Facts

1

Connectivity

- Serving **165** Customs points of entry (Customs stations, ports, airports and border crossings)
- Servicing **10,000** organizations with more than **13,000** users
- Connecting **25** Permit Issuing agencies and **8** local banks
- Connecting **6** major ports

2

Transactions

- More than **60 million** electronic transactions processed a year
- **RM1.8 billion** worth in Customs duty payments transacted annually

3

Coverage

- **24 x 7, 365** days a year operational support services
- Nationwide operations, supported by **7 regional offices**
- **Data Recovery & Data Replication** Facilities
- **99.8%** Reliability Service Level



National Single Window Services Features



Single Sign-On Data Reusability Security Transparency

More Efficient Export Process Minimise Human Error Secured Information Monitoring

Increase Competitiveness Time Saving Integrity Maximise Returns

Malaysia NSW Tariff Rate

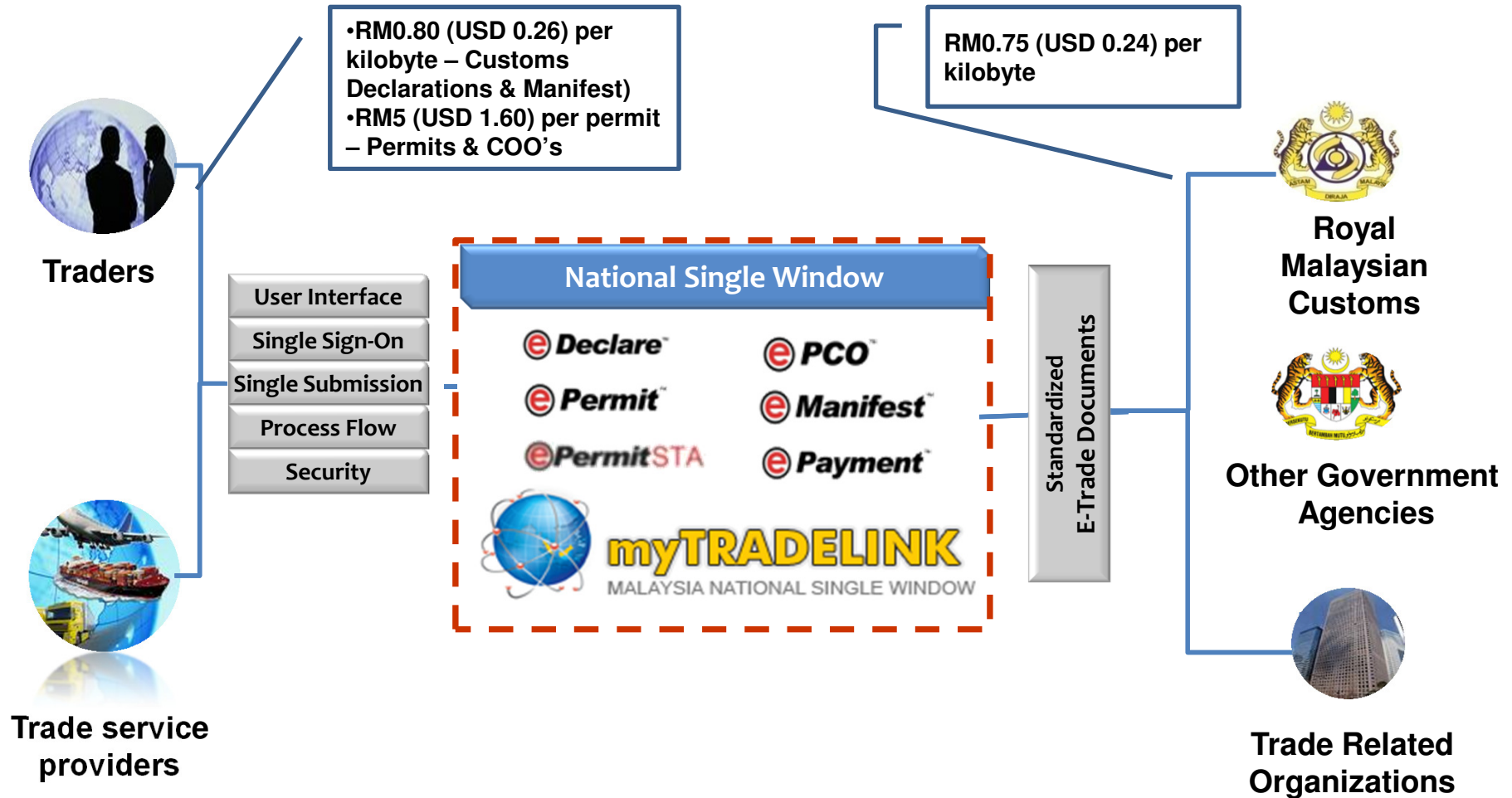

Malaysia NSW - Future Environment

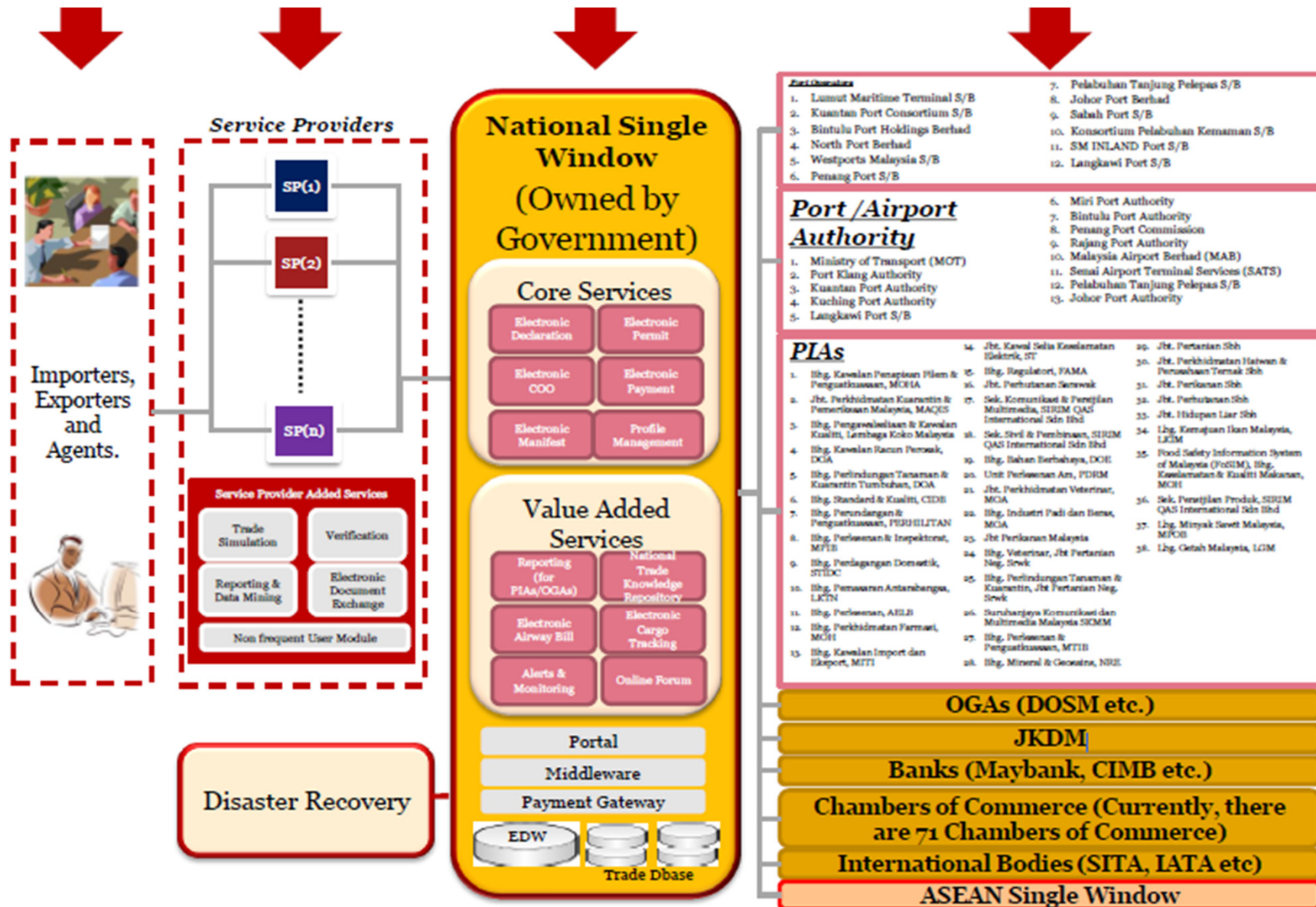

Malaysia NSW – Expansion of Stakeholder

Members/Parties for each stakeholders will increase due to the comprehensiveness and expanded capabilities of the NSW

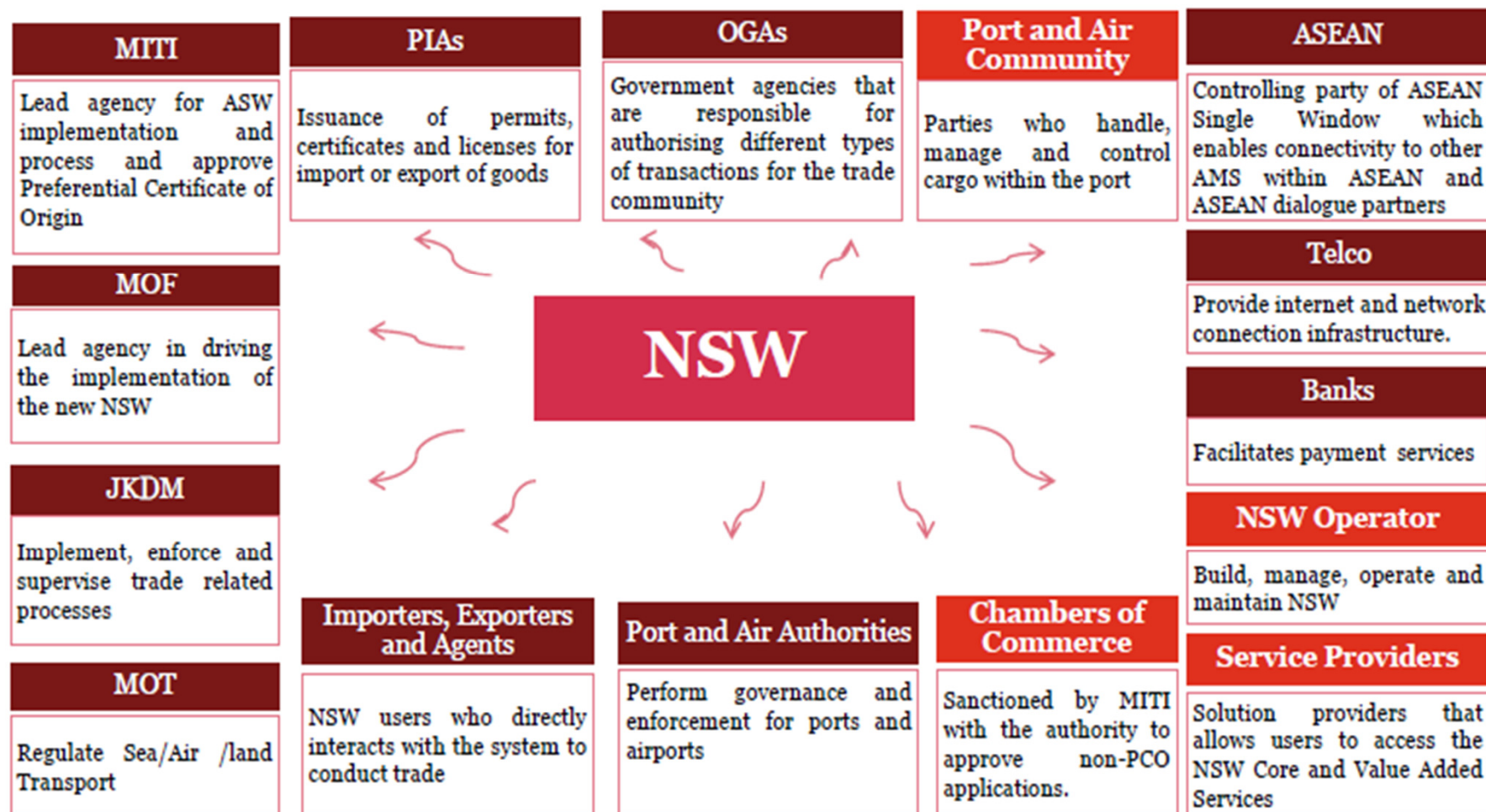

Malaysia NSW - Challenges

Challenges Prior to the implementation and deployment of the NSW

A strong political will and authority

Implementation of a data standardisation and harmonisation

Standardisation of trade processes and Re-Engineering of Business Process

Strengthening of coordination and communication amongst stakeholders

High commitment in terms of resources and budget amongst stakeholders

Investment on up-to-date technologies capable of catering for future enhancements and demands

Improving system delivery & service level (too many players involved and KPI for each player..DNT, Customs, Telcos, banks, etc)

Malaysia & Japan



Electronic Exchange for Certificate of Origin (MJEPA)

Background

Malaysia's Lead Agency : MITI

Japan's Lead Agency : MOF & Customs

Japan's Service Provider : NAACS (Nippon Automated Cargo Clearance System)

MJEPA (Malaysia-Japan Economic Partnership Agreement) Form will be used for the exchange

One way traffic – Malaysia to Japan only

Process Flow

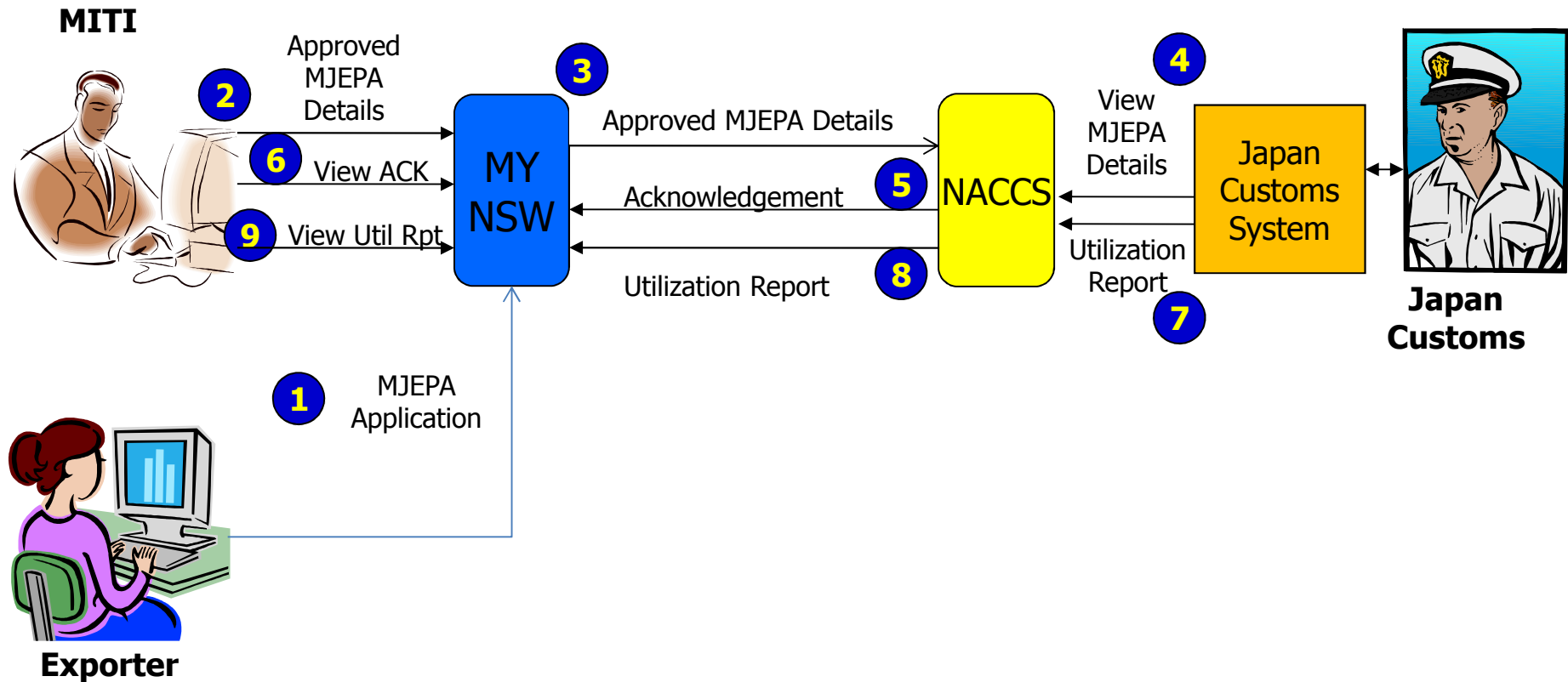

Challenges



MOU between both countries before live implementation

UAT (User Acceptance Test) with MITI's users

Moving Forward Plan

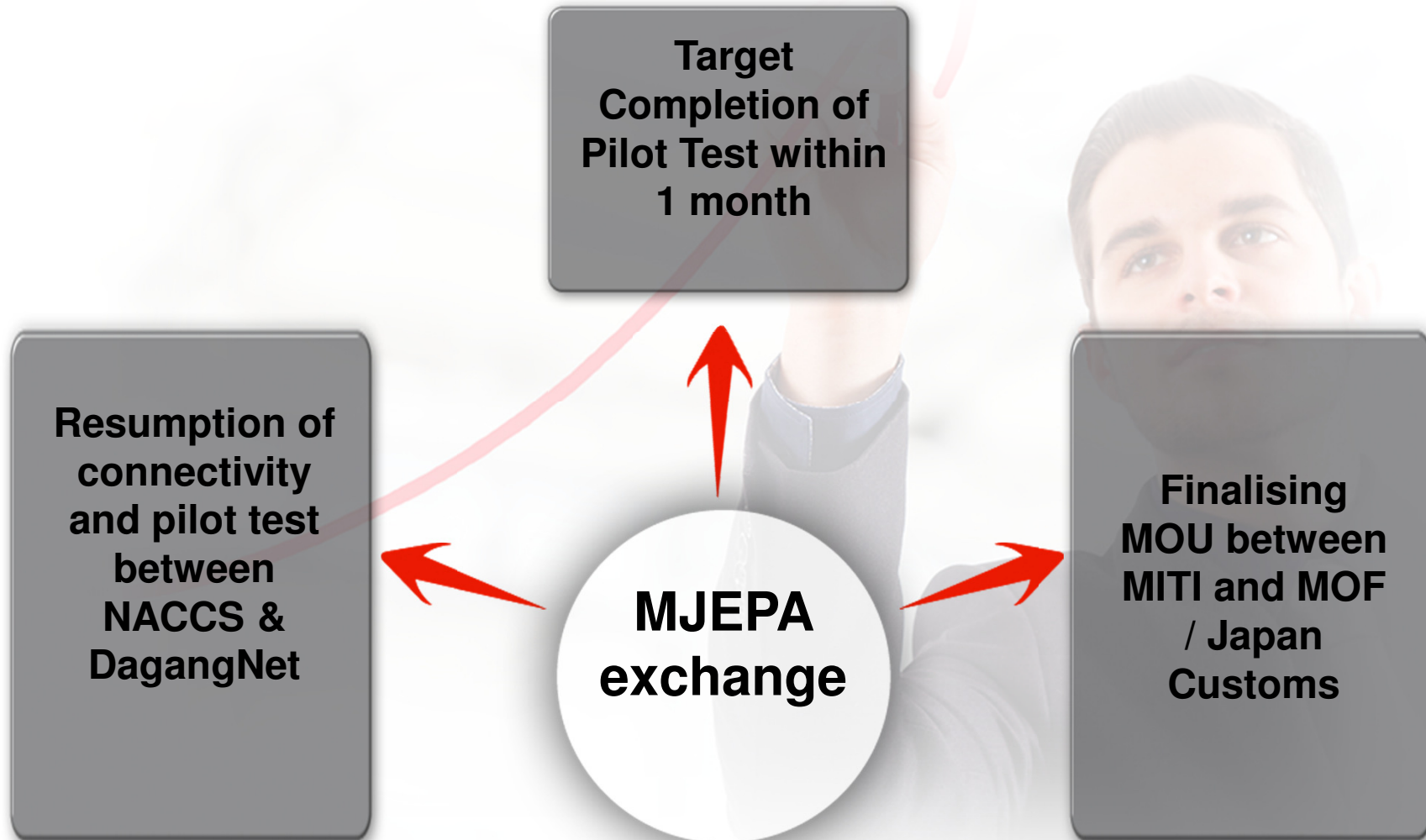

Questions & Discussion





Corporate Address

Dagang Net Technologies Sdn Bhd (177974-T)

Tower 3, Avenue 5,
The Horizon Bangsar South,
No 8 Jalan Kerinchi,
59200 Kuala Lumpur.

General Line: 03 2730 0200

Fax: 03 2713 2121

Careline: 1 300 133 133

Website: www.dagangnet.com

E-mail: info@dagangnet.com