

**2007.11.01 HCM AACC**



臺北近場管制塔臺

越南胡志明區域近場管制中心 參訪

MOT: Ministry of Transport  
CAAV: Civil Administration Aviation of VietNam  
VATM: VietNam Air Traffic Management

NAA: Northern Airport Authority  
MAA: Middle Airport Authority  
SAA: Southern Airport Authority

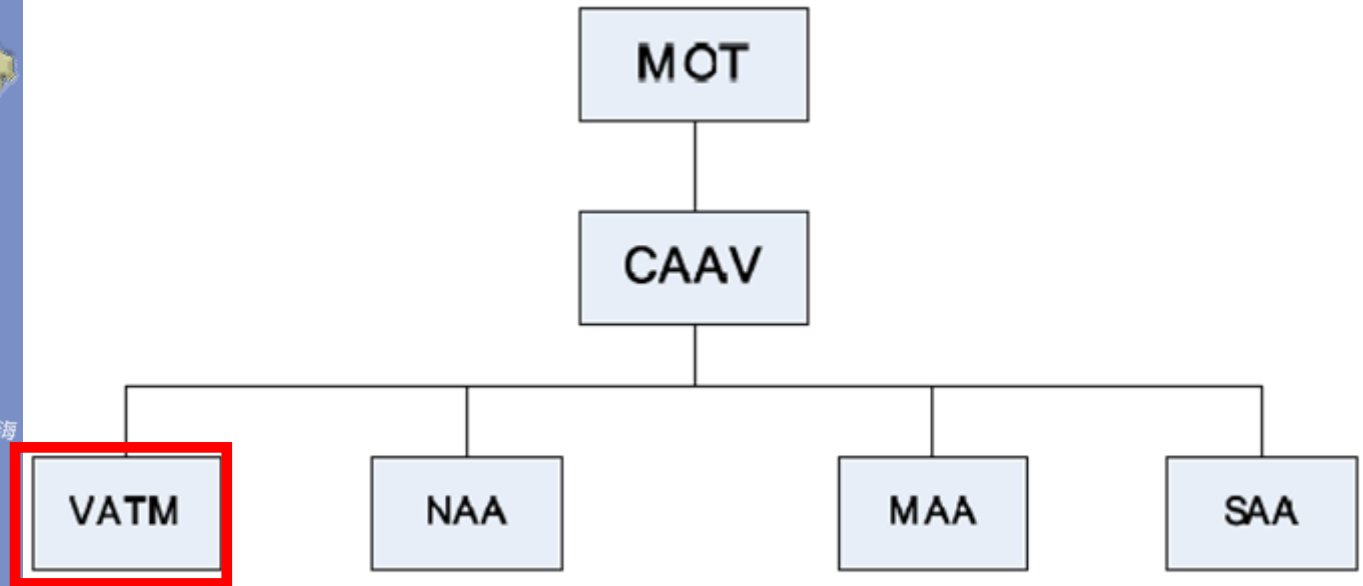

臺北近場管制塔臺

越南胡志明區域近場管制中心 參訪

VATM: Vietnam Air Traffic Management  
NORAT: Northern Region Air Traffic Services  
ATC&C: Air Traffic Command and Coordination

SORAT: Southern Region Air Traffic Services  
MIRAT: Middle Region Air Traffic Services  
ATTECH: Air Traffic Technical Services Center

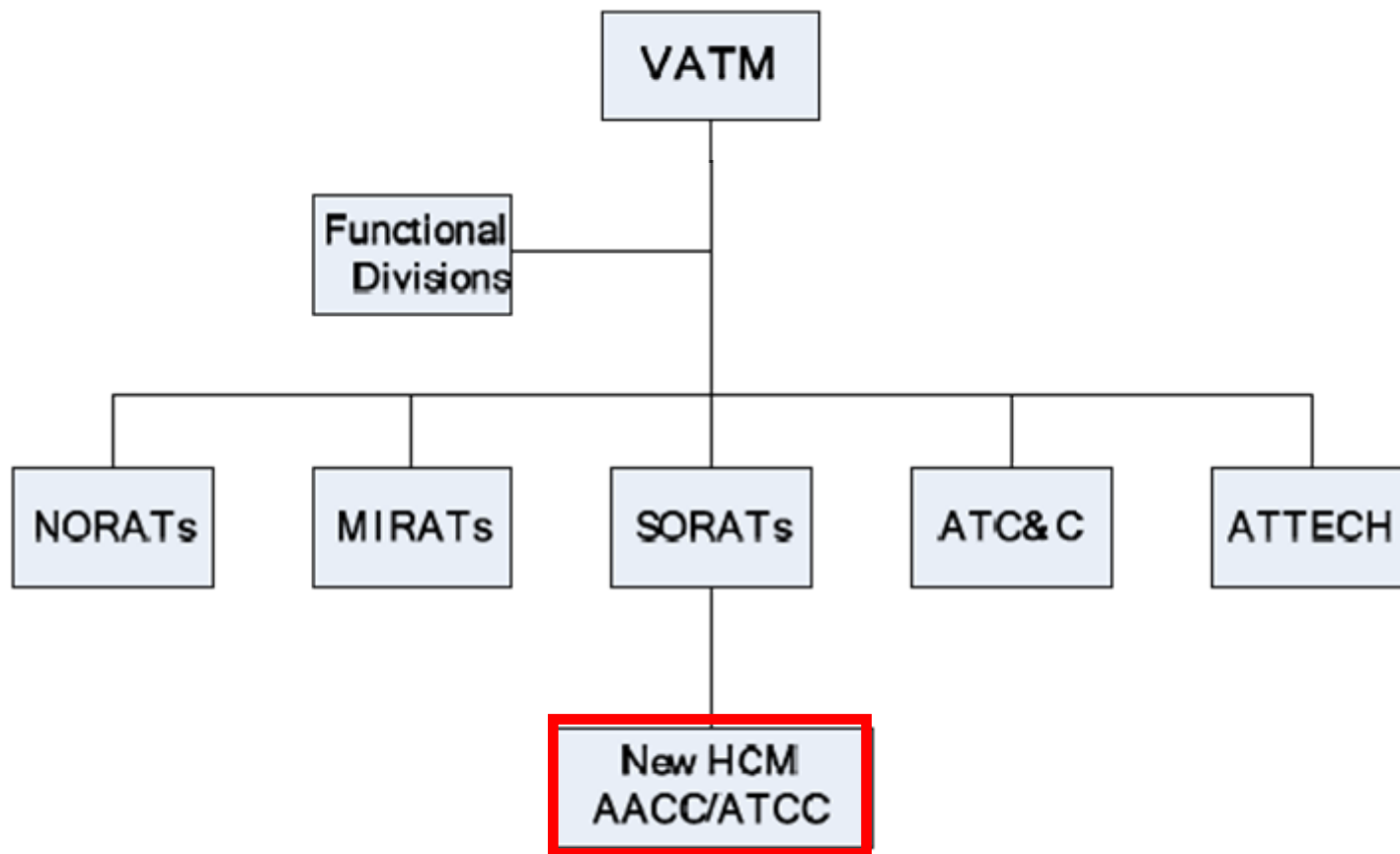

# VIETNAM AIR TRAFFIC MANAGEMENT



## VATM

- **Leader Board:**
  - + Director General
  - + 3 Deputy Directors General
  
- **Total staffs: 1910**
  - + Technical staff: 595
  - + Air Traffic Controllers: 422



# Southern Regional Air Traffic Control Services (SORATs)



- Main Functions and Duties:  
providing ATS services to all flights within HCM FIR
- Leader Board: Director and 3 Deputy Directors
- Total Staff: 612  
+ Technical staff: 226  
+ Air Traffic Controllers: 187
- Average number of traffics operating within  
**HCM FIR: 650 flights / day**





## Existing HCM ACC:

- Operated: in 1990
- Located at: 22-Tran Quoc Hoan Street.
- Responsibilities Area: HCM FIR **5 Sectors**
- Adjacent ACCs: SIN, KUL, MNL, BKK, VTE, PHN, SANNYA, HAN.



# Existing TSN APP:



- Operated: in 1990
- Located at: 22-Tran Quoc Hoan Street.
- Responsibilities Area: Tan Son Nhat
- International Aerodrome and local Aerodromes in the South
- **2 Sector**



# HOCHIMINH AACC PROJECT



- **Project Objects:**

Meeting the forecasted traffic growth until **2020** and beyond with new technical systems of advanced technology and compliant with CNS/ATM requirements.

Satisfying the future evolution of SORATS.

- **Scope of the Project:**

Construction of a new HCM AACC Building, an **Administration Office Building** and a **Sporting and Entertainment Area**

- **Total Capital:** 360 billion VND (equal to **22 million USD**)





# Duration of Project Implementation:



- Feasibility Study Project started: in **2001**
- Implementation started: in 2002
- Acceptance Test: December 2005
- ATC Transition: 1st Mar 2006
- Official Operation: **12th May 2006**



# The core technical systems manufactured by:



- **Automation Management Air traffic Control system:**

- Product name: **AEROCAT-X**
- Manufacturer & Supplier: **Thales corporation**

- **VCCS system:**

- Product name: VCS 3020X Rel 3.1
- Manufacturer & Supplier: Frequentis



# THE AIR SPACE STRUCTURE in HCM FIR



- **En-route control area:**
  - The entire of Ho Chi Minh FIR
  - Sectorisation: 05 sectors
  
- **Approach Control area:**
  - Tan Son Nhat TMA
  - Sectorisation: 02 sectors
  
- **Aerodrome Control Tower:**
  - 16 civil control towers





## Surveillance services provided by Air Traffic Control Automation system (ATMS) which is connected with:



- **06 SSR** stations located at DaNang, QuiNhon, TanSonNhat and CaMau, Vinh, Noi Bai (250NM each).
- **03 PSR** stations located at DaNang, TanSonNhat, Noi Bai (80NM each).
- **ADS** via ARINC Network
- Surveillance coverage: All Viet Nam FIRs.



# Communication services provided by VCCS system which is connected with:



- **G/G Communication by VSAT & Optical cable:**
  - Voice communication
  - Data link communication (AIDC, OLDI)
  - AFTN Network
- **Air/Ground Communication:**
  - VHF(06 at TSN), Extended VHF (4 at Sontra, Quinhon and Camau)
  - HF SEA II as back-up frequencies.
  - CPDLC via ARINC Network





# The simulator system is a partition of ATMS system

- The simulator system includes:
  - 04 dual ATC training positions
  - 08 pseudo pilot positions
  - Instructor position
  - Target generator & leader position
- **Purpose of the simulator system:**
  - Controllers' OJT, proficiency, new procedure training
  - Refresher training and emergency training





Automation Air Traffic Management System (ATMS) has been installed in the new Ho Chi Minh ATC building since 2004.

- It consists of:(席位)
  - 10 dual positions and a supervisor for ACC.
  - 04 dual positions and a supervisor for APP.
  - A dual position for Tower.
  - 02 positions for FDO.
- The system has also the capability to be used as a Backup of Hanoi ACC.
- In addition, the system includes a simulator partition for the purpose of training both of Enroute and TMA controllers.





# Automation Air Traffic Management System (ATMS)



- **Providing surveillance functions:**
  - Radar tracks within radar coverage
  - ADS track of appropriately equipped aircraft,
  - Extrapolated tracks based on coordinated FPLs
- **Providing safety net services:**
  - Short Term Conflict Alert
  - Minimum Safe Altitude Warning
  - Danger Infringement Warning
  - RAM, CLAM, ETO, FPCF (Medium term conflict function)...
- **Supporting communication functions:**
  - Air-ground com by using CPDLC application
  - G/G communications by using AIDC application



# Preparation tasks for commissioning of new AACC HCM Training for Controllers



- **Factory training:**
  - 16 ATC instructors
  - Course duration: Ten weeks
  - Training contents: ATC, Simulator, Database Functions
- **On site training:**
  - Participants: All en-route & TMA controllers
  - Duration: **03 months**
  - Training contents: ATC + FDO functions



# Training for Technicians



- **Factory training for every technical systems:**
  - Duration: Two weeks
  - Participant: Senior engineers
- **On site training:**
  - Duration: 03 months
  - Participant: All technicians concerned



# The transition plan



- **The transition activities undergo four states:**

State 1: Test and evaluation (Sep 1, 2005-Jan 15, 2006)**4.5M**

State 2: Operational trial (Jan 15, 2006-Mar 1, 2006)**1.5 M**

State 3: Transition (Mar 1, 2006- Mar 10, 2006)**10 D**

State 4: Post Transition (Mar 10, 2006 – May 24, 2006)**2.5 M**



# Several typical project on VATM in the future



- Project "New TanSonNhat International Airport TWR"  
Feasibility Study has been approved  
Expected time of completion: end of 2007
- Project "New Noi Bai International Airport TWR"  
Feasibility Study has been approved  
Expected time of completion: end of 2007
- Project " Aeronautical Information Services Automation System"  
Feasibility Study has been approved  
Expected time of completion: end of 2007
- Project " New HaNoi ACC"  
Feasibility Study shall be approved in 2007  
Expected time of completion: end of 2009

