

出國報告（出國類別：出席國際會議）

赴美國華盛頓參加
「79TH ANNUAL AAAE CONFERENCE AND
EXPOSITION」會議
報告書

服務機關：交通部民用航空局

桃園國際航空站

姓名職稱：范榮春/組長

派赴國家：美國

出國期間：96.6.9-96.6.15

報告日期：96.6.29

目 錄

一、 目的	3
二、 行程經過摘要	4
三、 訓練內容摘要	5
(一) 會議第一天(96.6.10)	5
(二) 會議第二天(96.6.11)	7
(三) 會議第三天(96.6.12)	9
(四) 會議第四天(96.6.13)	10
四、 心得與建議	16
五、 附件	18
六、 備註	73

一、目的

為加強航站之企業化經營管理觀點，擴大與全球先進機場專業營運知能、技術之同步接軌，並吸取最新之相關場站設施及飛航安全作業各項規範，乃前往參與目前全球於層次最頂尖，專業技能最先進，飛安措施最嚴謹，場站設施最完善及經營理念最靈活與獲利最佳之美國機場經理人協會 AAAE (American Association Of Airport Executives) 79 年度會議，藉由參與其專業高階經理會議，以期分享及學習該會所轄相關機場經營方式與經驗，並與其政府部門官員當面溝通與瞭解，現階段推動之重要政策，爰核派本站企劃組組長范榮春，參加 96 年 6 月，由美國華盛頓機場管理局 (Metropolitan Washington Airports Authority, MWA) 於華盛頓舉行的「79TH ANNUAL AAAE CONFERENCE AND EXPOSITION」會議，期間 6 月 10 日至 6 月 13 日為期四天，藉以吸取此次會議新興之專業課題、相關技術及經營理念，並擴展與美國各相關機場情誼及吸取推動業務實務經驗，俾提供本站未來於經營管理作業上之參考。

二、行程經過摘要

職於 96 年 6 月 9 日搭乘長榮航空公司班機啟程赴美，經將近 12 小時飛行抵達洛杉磯（Los Angeles）國際機場，通過嚴密安檢及移民官員嚴謹詢問本次入境美國之目的後准許入境，經在洛杉磯機場停留約 6 小時搭乘美國航空公司（American Airline）轉機至華盛頓杜勒斯國際機場（Washington Dulles International Airport），到達時間為當地 10 日早上清晨 5 時 50 分許，總行程將近 23 小時。

美國機場經理人協會（American Association Of Airport Executives，AAAE），固定於每年六月以輪流方式由具相當規模機場定期舉行機場主管與航空產業、政府公部門 TSA（美國運輸安全局 Transportation Security Administration）、FAA（美國聯邦航空總署 Federal Aviation Administration）等會議，藉由面對面經驗交流，主要政策推動、以及提供最新及航空設施改善與新設之產品展示，對提昇航空產業之發展有相當正面意義；本次會議選定於美國首都華盛頓文化氣息濃厚地區舉行，除彰顯出美國國力強大的一面，也讓職感受到美國在有關飛航安全與反恐措施的實事求是的精神，至於本次會議之相關議程資料（如附件 1）。

本次會議議程於 6 月 10 日開始為期四天，至 6 月 13 日下午結束，職於 6 月 14 日中午自 Washington DC 出發，搭機至洛杉磯國際機場，於 6 月 15 日凌晨 1 時搭乘長榮航空公司班機，並於 6 月 16 日清晨返抵台灣桃園國際機場。

三、訓練內容摘要

此次會議內容是以會議研討及航空產業產品展示方式舉行，會議並以安排現場展示會、相關委員會及以共同性會議方式呈現，展示之各廠商並安排各場次之說明會，方便與會人員瞭解產品之功能；另因機場董事會成員和委員是 AAAE 年刊會議主要的整體一部份，因此會議是以研討影響機場和航空公司產業中相關政策為主要議題，會中並邀請學有專精之人士提出相關研究論述，及美國聯邦航空總署（Federal Aviation Administration, FAA）、美國運輸安全局（Transportation Security Administration, TSA）及華盛頓機場管理局（Metropolitan Washington Airports Authority, MAAA）等主管機關參與本次會議之舉行。

本次會議總計 4 天，相關會議規劃方案（詳如附件 2），茲將每日詳細會議內容、學習心得及重要記事，以日誌方式陳述如次：

一、會議第一天：

（一）會議時間：08:00am—09:30pm

（二）會議地點：華盛頓會議中心（Washington Convention Center）

（三）會議重要事項：

1、展示會場協調會及開放參觀。

2、AAAE 委員會會議。

3、Concurrent Sessions：

（1）Cargo Security Update - Industry Concerns

重點摘要：在過去二年以來，航空產業經由美國運輸安全局訂定在空運貨物安全和新的規則後，並且已經開始履行新的規則；今年美國國會更將著眼於貨物安全，並增加區分研討相關部分航空產業；此次會議並將討論到機場未來發展情形，衝擊和挑戰機場與航空貨運產業等相關議題。

(2) Safety Management System – Understanding New SMS
Implications For Your Airport

重點摘要：經由本次會議將更進一步探究新的美國機場的安全管理系統的需求與發展，其中美國聯邦航空總署 (FAA) 和企業界專家並將協助討論以有系統的，明確的、包羅萬象的和積極的程序以管理機場風險。

(3) What ' s Up with the Accreditation Program and What Has Remained Constant?

重點摘要：本次會議將說明若干的改變已經發生在改善信賴計畫，且於會議中將由本項檢查工作之 AAAE 董事會負責說明，你將有一個機會發現什麼是新的和什麼已經保持不變政策方向，你或許有機會與主要檢查員人員，面對面溝通與瞭解執行經驗與相關缺失，出席者並將於會議結束時收到信賴計畫之課程光碟。

(4) Getting a Bigger Slice of the GA Pie - Washington Perspective on the General Aviation Industry

重點摘要：本次會議將說明那些初級組織，正在代表著一般的航空產業在華盛頓執行什麼政策與事像並獲取何利益？這會議將說明未來發展願景和帶給出席者在現在的航空企業加速發展契機；來自 AOPA、NATA、NBAA 和 AAAE 的代表將展現於面對聯邦調查局、國會山莊上被討論的議題上，他們的遠景和答案問題；至參加其他的一般的航空機場主管，FBO 代表，商業航空、社區和其他的航

空領袖的成員和繼續獲至來自華盛頓因權利授予而獲得在航空企業發展的最佳利益來源。

(5) Trends in Airline Use and Lease Agreements - Staying Flexible In Today ' s Economy

重點摘要：處在當前經濟的、高度發展性的航空公司產業中，運用協商方式協調事項，及處理相關爭議政策，以期將過程轉變得更有彈性和創造力的，這會議將探究一些最新發展。

二、會議第二天：

(一) 會議時間：07：30am—05:30pm

(二) 會議地點：華盛頓會議中心 (Washington Convention Center)

(三) 會議重要事項：

1、展示會場協調會及開放參觀。

2、AAAE 委員會會議。

3、Concurrent Sessions：

(1) Registered Traveler Program - RT: Convenience For Travelers, Opportunities for Airports

重點摘要：做好相關旅遊行程之紀錄方案，在早先的時期提出，就記錄其互通性組織將會尋求航空產業和 TAS 提出創新方案，並推動機場開放和推動政策；加入這課程及學習記錄旅遊者方案，包括在你的機場須要搭乘何種交通工具、安排相關行程等計畫，以期有機會於事先因資訊的取得而獲取相關龐大利益。

(2) Innovative Terminal Concessions and Retailing Trends - How Concessions Programs Impact the Traveler

重點摘要：在早期的時代，有可能是長距離與時間的安全航線和擁擠的飛機，乘客期待機場管理者能提高對參與旅行的便捷和提供滿意的服務，以符合旅客的期待與需要。

(3) Construction Project Management - Overseeing Hard Hats and Concrete

重點摘要：本次會議在討論機場管理技術和相關計畫項目，風險評估，成本預算，預測和經濟評估，它也將提出相關規劃方案和融資議題，如此的作為縮短而且尋求服務，供給組織溝通，而且確定資料的有效使用及經費編列。

(4) Panel of Airline Planners - Solving The Route Map Puzzle

重點摘要：一位機場經營者的初期責任之一，是由足夠的吸引服務於圍繞著社區的機場的航空業務。

在這次會議中，你將得到的瞭解航空公司如何決定經營航線，而且將航空公司人員的負責說明；這些資訊將使機場經營者能夠接近而且發展和航空公司的堅強的關係，不創造不必要的干擾，以吸引最好的可能的航空業務。

(5) The ABCs of ATC - Long-Term ATC Modernization

重點摘要：本次會議將討論處於擁擠天空的年代，對於未來航路發展，出席者將提供最新的空中交通管制系統方面的一種遠景；從現在起它將被預測那一位超過十億位乘客 2015 之前仍將提供服務以滿足至少十年。

以在當前市場上的，新且非常輕的噴射機的數量

加倍成長前題，空中交通管制系統將需要徹底檢查增加能力和效率，參加來自美國航空管理局的接合計劃的代表和發展辦公室和其他的工業領袖將說營未來支應我們的是什麼 ATC 的新設施。

三、會議第三天：

(一) 會議時間：08:00am—06:30pm

(二) 會議地點：華盛頓會議中心 (Washington Convention Center)

(三) 會議重要事項：

1、展示會場協調會及開放參觀。

2、AAAE 委員會會議。

3、Concurrent Sessions：

(1) TSA Roundtable Discussion—Face to Face with TSA Policy Leaders

重點摘要：針對當前航空工業的進行之中之相關的議題的簡報與參與之 TSA 官員，討論如何將把重心集中在最近的 TSA 推動的安全政策，包括主動的立法，在共有貨物方面的增加安全的衝擊、資金和收入改變，和將來的主動的行動策略。

(2) FAA Roundtable Discussion - Face to Face with FAA Policy Leaders

重點摘要：美國航空管理局 Roundtable 為機場的非正式討論議題，並由美國航空管理局的資深政策制定者和機場管理者聯合出席本次會議，會議中並將有機會瞭解相關發展資料關於 AIP 和 PFC 的計畫、發展趨勢和規範標準等。

(3) FAA Design Competition Panel

重點摘要：美國航空管理局設計專門小組， AAAE , ACI - NA 和維吉尼亞空間授與協會共同贊助者，將說明機場營運管理在技術上的三個大範圍設計挑戰，包括：機場手管理和維護挑戰、跑道安全/跑道侵入挑戰、和機場環境的交互作用挑戰等重要事項。

(四) 參訪華盛頓杜勒斯國際機場 (Washington Dulles International Airport)

重點摘要：華盛頓杜勒斯國際機場，是花費四十三億美元的之杜勒斯首都建築計畫中，杜勒斯發展(D2)的位置所在，本計畫被設計發展以符合乘客交通便捷和完善機場管理的機場；主要的 D2 計畫被設計改善傳統旅行經驗而且因應機場的擴展及使用，機場旅遊將以 Aero Train 的建築，地下型的機場捷運系統為特色，(在)集合 B 的場站擴建，以及第四條跑道興建位置和更多新盈建築設施等等! (詳如附件 2)

四、會議第四天：

(一) 會議時間：08:00am—11:00pm

(二) 會議地點：君悅飯店 (Grand Hyatt Washington)

(三) 會議重要事項：

1、展示會場關閉。

2、AAAE 委員會會議。

3、Concurrent Sessions：

(1) Screening Checkpoint Technologies - How Will Technology Change the Customer Experience

會議摘要：以滿足日益增加的乘客需求，在有創造力的科技

方面，以全面改善安檢檢查能量，可否提高安全和消費者經驗嗎？

在這會議中我們將探究最近的檢查技術，而且就目前的安全管理措施發表演說，以說明未來將影響之乘客、機場和航空公司之重要訊息。

(2) Aviation Ground Handling Issues - New Solutions To Resolve Old Problems

會議摘要：本次會議 DBE 將包括，有屬於航空土地的處理，經由相關經驗與想法的意見交換，並且在該如何提高航空地面處理方面上對談，並提供與會新的系統分析方法學和新的操作的想法和技術。

(3) Partnering with Local Chambers/Economic Development Organizations/Convention Bureaus to Attract Air Service - Capturing New Air Service by Creating a Unified Strategy

會議摘要：為吸引而且維持航空企業發展與營運，將提供機場商業貿易概念，本次會議將提出創新的方法與你的社區和地方商業合作，在航機上帶來新的航空運送概念加強合作，並且獲得其他的機場管理相關新的訊息。

(4) Wall Street View of the Airline Industry - Bankruptcies to Mergers: A New Airline Industry Emerges

會議摘要：一種展新的航空公司企業出現，儘管噴射機燃料價格增加，航空公司在改善財政結構方面，就 2006 年以來財政專家，如何研議可能的破

產和合併方案可能影響航空產業未來發展。

(5) Emerging Baggage EDS Technologies - New Strategies To Ease Delays, Errors

會議摘要：未來為行李 Edmund 技術將支持什麼？這會議將把重心集中在正在被發展使行李成為紗網材料，且比較快速的、便宜的、小的和更安心的技術，當他們討論 Edmund 供應者正在為下一個進行中的時候，參加與會專家小組將發表新世代的行李檢查技術，及相關利益，費用和如何落實這些技術。

(6) Being Proactive and Prepared—GA Airport Security/Safety Update

會議摘要：最近發生，如在紐約的2006年十月蔓藤 SR-20 飛機意外事件，而且來自國會山莊的壓力已經產生為一般的航空安全的漏洞和條例更新意向。

無論它正在增加新的技術保護機場財產或推行新的程序確定不過經認可的人有機會接近限制區域，GA 機場需要計劃讓最好的方法處理潛在的威脅情形和接近的條例。

(7) Customer Service Challenges at Airports—Customers First Makes Airports Number One

會議摘要：在你的機場提供新盈的消費者服務和重視環境影響，較每天對想要是安全的和安心的旅客比平常是更重要的，但是同時對於不斷改變的安全規則和被聯邦政府強制改變的條例失望，本

次會議將提供專家研究資訊，讓你了解當前議題和在你的機場傳送例外的消費者服務的方面概念，以及如何達成本項目標。

(8) Airport Master Planning Trends – Drafting the Future

會議摘要：機場綜合計劃是計劃建設和機場發展的基本的工具，藉由各項計劃上的一個相對新的建議，美國航空管理局正在強化對機場的需要發展，而且再檢視機場綜合計劃。

藉由 2015 之前預測十億位乘客的航空成長的整體的預測，機場現在需要開始更新並且修訂他們的綜合計劃，本次會議將把重心集中在發展計劃中適合機場大小的的發展之綜合計劃。

(9) Panel of Airline Properties Representatives - Deal or No Deal

會議摘要：來自航空運送者的財產所有者和貨物運送者將在機場討論，當地州機場和航空公司關係，和主要的挑戰，以及面對航空業的未來機會。

(10) Federal Inspection Services Update – FIS Changes Ease Lines, Passenger Delays

會議摘要：國際的航空業務是一個任何機場的生意模型的關鍵所在，當現在的航空市場變成以容納過多的旅客，而且競爭增加的時候，吸引國際的航空業務變成一個需要和必要的機場的未來，發現一些可以使國際的過度發展或侵蝕現有的國際的航空業務的限制時，和你的同業探究該如何對這些情況產生反應和選擇可以解決可

能的替代方案。

(11) Airport Community Outreach - Creating A Supportive Neighborhood

會議摘要：並非每個社區不能夠是像羅傑先生一樣的完美，不過機場為了要最保存機場的和周圍的鄰居，其中又強化的社區關係是一國非長有趣研究議題，本次會議將探究成功的社區發展，而且結合機場以達整體性發展。

(12) FAA Reauthorization - Debate Heats Up as Expiration of Current Authorization Bill Nears

會議摘要：美國航空管理局重新批准之預算，將在九月期滿，而且國會正在開始把審議重心集中在將為機場進步和小的團體航空業務發展計畫決定資金水準的重新核准；且他們並發覺國會山莊、政府官員的專門小組正為乘客設備費用和其他的機場優先審議、討論。

(13) Airport Legal Issues: If You Run an Airport, You Need a Lawyer

會議摘要：本次會議將由機場合法的專家檢討趨勢和能影響你的機場的管理的發展，因機場環境的複雜，機場擁有者和管理者面對獨特的合法的挑戰和能直接地影響機場的管理的情形，從管理對航空業務發展計劃的所導致的環境的風險，你需要瞭解現在的合法的架構是什麼，而且你能如何避免使你的機場暴露在昂貴的責任中。

(14) Airport Management Succession - Training Heirs to The Throne

會議摘要：在機場管理方面計劃早已經被考慮成功的機場的管理的每個方面的一個關鍵的因素。

有些人員對必需的技術準備與將來的工作機會而且努力，和社區政治環境和價值，是管理者成功轉變和責任重要的在關鍵位置。

為長期培訓計劃一個經營團隊的管理者，就像提供較佳設備，商業活動和財務的相關計劃是一樣的重要。

四、心得與建議

美國是一個航空產業高度發展的先進國家，擁有全世界最多的營運機場，最為尖端的航空企業，以及最為嚴謹的政府組織，全面經營航空事業，本次舉行的 AAAE (American Association Of Airport Executives) 美國機場經理人協會已經是第 79 屆，今年的會議遠遠超越去年在聖地牙哥參加會議贊助者或展示者總數 2500 人以上，且經由此次會議將可提供推展航空領域最好的方法與計畫方案。

參與本次會議除具有上述功能，期能藉以吸取此一新興之專業課題與技術、經營理念，並擴展與美國各相關機場情誼與推動業務實務經驗，以為後續本站於經營管理作業之參考，茲將相關學習心得陳述如次：

(一) 瞭解最為尖端航空產業：

此次展示之相關設施範圍有：消防車輛、行李輸送設備及安全管理系統等軟硬體產品不勝枚舉，可提供本機場未來建置與增設參考。

(二) 提供與航空工業廠商和政府的高層主管意見交流：

經由本次會議可面對面溝通瞭解當前航空產業發展、研發與各項設施功能，另藉由會議期間可瞭解、預測未來 TSA (美國運輸安全局 Transportation Security Administration)、FAA (美國聯邦航空總署 Federal Aviation Administration) 等政府部門政策方向。

(三) 吸取機場管理者經營理念：

本次與會者大多為美國現任機場專業高階經理人，因此透過會議之參與

分享及學習機場經營方式與經驗，受益良多。

(四) 機場管理問題經驗分享：

經由會議意見交換充分瞭解對機場的解決辦法方面，包括如何運作、營運和管理上問題。

(五) 航站建設新技術：

此次會議曾參訪華盛頓杜勒斯國際機場 (Washington Dulles International Airport)，對該機場為因應空中巴士 A380 營運，新建第五座航空站 (Terminal) 及第四條跑道，其工程技術之專精與預期如何營運管理之航站規劃及捷運路線設計等鉅細靡遺，另人印象深刻。

總之航空事業之發展將是無遠弗界，處在這競爭劇烈的年代，除應學習與接受相關先進技術設施，更須因應相關新進之各項作業規範，以期與全球同步接軌，不故步自封才能為其他先進國家所尊敬與接受，時應為我們應努力方向，至於就參加本次會議後個人建議事項如次：

(一) 鼓勵國籍航空公司應踴躍參與以增廣見聞。

(二) 於經費寬裕的前題下能增派人員參與以接受新知。

五、附件

(一) 附件1：79th Annual AAAE Conference and Exposition Agenda (Subject to Change)

(二) 附件2：79TH ANNUAL AAAE CONFERENCE AND EXPOSITION—CONFERENCE PROGRAM

(三) 附件3：79TH ANNUAL AAAE CONFERENCE AND EXPOSITION—WELCOME TO WASHINGTON DULLES INTERNATIONAL AIRPORT CAPITAL CONSTRUCTION PROGRAM TOUR

附件 1

79th Annual AAE Conference and Exposition Agenda (Subject to Change)	
Saturday, June 9	
8 a.m.-5 p.m.	Exhibitor Registration and Exhibitor Set-Up
8 a.m.-12 p.m.	AAAE Board of Directors/Policy Review Committee Meeting
2-5 p.m.	Delegate Registration
Sunday, June 10	
6-10 a.m.	Exhibitor Set-Up
6 a.m.-7 p.m.	Exhibitor Registration
8 a.m.-7 p.m.	Registration
8-9 a.m.	AAAE Student Chapters Meeting – Chapter Reports (<i>open to all attendees</i>)
9 a.m.-5 p.m.	AAAE Accreditation Examinations
9-10:15 a.m.	AAAE Chapter Meetings Great Lakes Chapter Meeting Northeast Chapter Meeting Northwest Chapter Meeting Southwest Chapter Meeting South Central Chapter Meeting Southeast Chapter Meeting
9:30-10 a.m.	Exhibitor Meeting
10:30 a.m.-12 p.m.	AAAE Executive Business Meeting (Open to all members)
12-1:30 p.m.	Official Opening of the Exhibit Hall and Luncheon
12:30-2:30 p.m.	International Association of Airport Executives Board of Directors Meeting and Working Lunch
1:15-3:15 p.m.	AAAE Committee Meetings
1:30-2:30 p.m.	Airport Board Members and Commissioners Session
1:30-3:30 p.m.	Exhibit Hall Open
3:30-5 p.m.	AAAE Academic/Student Chapters Workshop (<i>open to all attendees</i>)
3:45-4:45 p.m.	Concurrent Sessions
6:30 p.m.-9:30 p.m.	Evening Event at Udvar-Hazy Center Sponsored by MWAA
Monday, June 11	
7:30 a.m.-5 p.m.	Registration

7:30-8:30 a.m.	Breakfast with the Exhibitors
8:45-9:15 a.m.	Official Conference Opening Ceremonies
9:15-10:30 a.m.	Opening Session
10:30 a.m.-12 p.m.	Visit with the Exhibitors and Refreshment Break
12-1:30 p.m.	Luncheon with Keynote Speaker
1:30-3:30 p.m.	Visit with the Exhibitors and Refreshment Break
1:45-3:15 p.m.	AAAE Academic/Student Chapters Workshop – Student Perspectives on Airport Management (<i>open to all attendees</i>)
3:30-4:30 p.m.	Concurrent Business Sessions
5-6:30 p.m.	Corporate Appreciation Reception in the Exhibit Hall
Tuesday, June 12	
8 a.m.-12:30 p.m.	Registration
8 a.m.-12:30 p.m.	Exhibit Hall Open
8 -9 a.m.	Breakfast with the Exhibitors
9-10 a.m.	General Session with Keynote Speakers, Tom Schmitt, CEO, FedEx Global Logistics & Supply Chain, Senior Vice President of FedEx Solutions Arnold Perl, Chairman of the Board, Memphis Shelby County Airport Authority
10:15-11:45 a.m.	Student Perspectives on Airport Management
10:30-11:30 a.m.	U.S. Contract Tower Association General Membership Meeting
10:30-11:30 a.m.	Final Exhibit Hall Hours and Foundation Hourly Prize Drawings (must be present to win)
11:30 a.m.-12:30 p.m.	Lunch with the Exhibitors
1-4 p.m.	MWAA Airport Tours (valid government-issued ID must be shown when boarding the bus)
1:30-6:30 p.m.	Golf Tournament
1-8 p.m.	Exhibit Hall Tear Down
1-3 p.m.	Round Table Discussions Large and Medium Hub Airports Small Hub Airports Non-Hub Airports General Aviation Airports
Wednesday, June 13	

7-10 a.m.	Exhibit Hall Tear Down
8 a.m.-3p.m.	Registration
8-9:30 a.m.	AAAE Executive Business Breakfast (all delegates welcome)
9:30-10:30 a.m.	Concurrent Business Sessions
10:30-11 a.m.	Refreshment Break
11 a.m-12 p.m.	Concurrent Business Sessions
11 a.m-12 p.m.	Airline Properties Representatives Roundtable
12 -2 p.m.	AAAE Awards Luncheon with Keynote Speaker The Honorable Mary Peters, Secretary, U.S. Department of Transportation
2:15-3:15 p.m.	Concurrent Business Sessions
3:30-4:30 p.m.	AAAE Board of Directors/Policy Review Committee Meeting
6-6:45 p.m.	Chair's Reception
6:45-9 p.m.	79th Annual Conference Banquet Hosted by Metropolitan Washington Airports Authority
9-11 p.m.	Dessert Reception Hosted by Louis Armstrong New Orleans International Airport

79TH ANNUAL AAAE CONFERENCE AND EXPOSITION

June 10 – 13, 2007 • Washington, D.C.

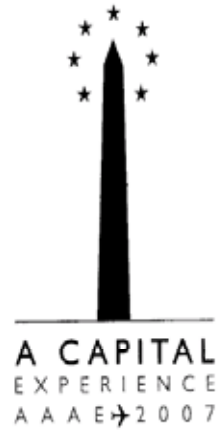

CONFERENCE PROGRAM

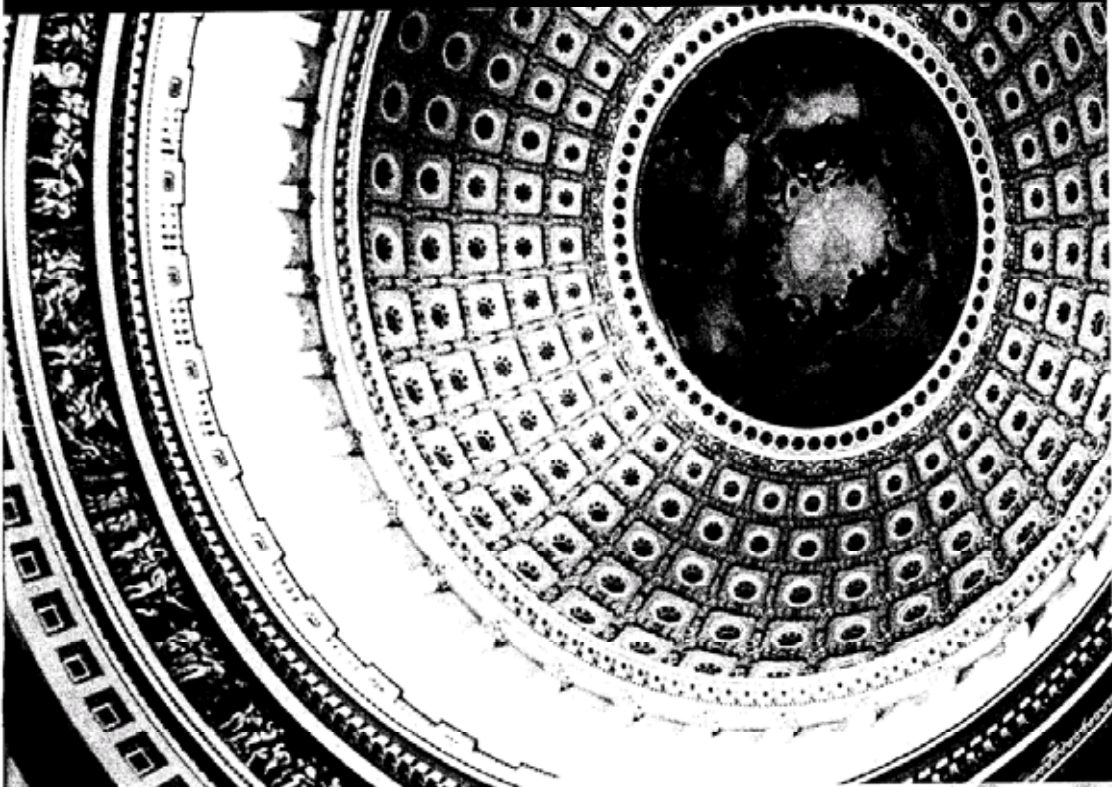

HOSTED BY



METROPOLITAN WASHINGTON AIRPORTS AUTHORITY

Schedule at a Glance

SATURDAY, JUNE 9

**All sessions will be held at the Washington Convention Center*

8 a.m.-5 p.m.	Exhibitor Registration	Concourse A
8 a.m. Noon	AAAE Board of Directors/ Policy Review Committee Meeting	Constitution A/B Grand Hyatt Washington
2-5 p.m.	Delegate Registration	Concourse A

SUNDAY, JUNE 10

**All sessions will be held at the Washington Convention Center unless otherwise noted. All meeting rooms are located on Street or Third Levels*

6 a.m.-4:45 p.m.	Exhibitor Registration	Concourse A
8 a.m.-4:45 p.m.	Delegate Registration	Concourse A
9 a.m.-5 p.m.	AAAE Accreditation Examinations	Grand Hyatt Washington
9:10:15 a.m.	AAAE Chapter Meetings	
	• Great Lakes Chapter	Room 144A
	• Northeast Chapter	Room 144B
	• Northwest Chapter	Room 144C
	• South Central Chapter	Room 147A
	• Southeast Chapter	Room 147B
	• Southwest Chapter	Room 149A
9:30-10 a.m.	Exhibitors Meeting	Room 145A
10:30 a.m.- Noon	AAAE Executive Business Meeting	Ballroom A/B
Noon-1:30 p.m.	Official Opening of the Exhibit Hall and Luncheon	Hall A
12:30-2:30 p.m.	International Association of Airport Executives Board Meeting and Luncheon	Room 147A
1:15-3:15 p.m.	AAAE Committee Meetings	
	• Academic Relations	Room 147B
	• Airline Economics and Air Services	Room 149A
	• Finance and Administration	Room 147A
	• General Aviation	Room 144C
	• Foundation	Room 304
	• Operations, Safety and Planning	Room 146B
	• Technical Services	Room 145A

1:30-2:30 p.m.	Airport Board Members and Commissioners Session	Room 146A
1:30-4:45 p.m.	Exhibit Hall Open	Hall A
2:30-3:30 p.m.	Refreshment Break with Exhibitors	Hall A
3:30-5 p.m.	AAAE Academic/Student Chapters Workshop	Room 147B
3:45-4:45 p.m.	Concurrent Sessions	
	• Cargo Security Update – Industry Concerns	Room 146A
	• Safety Management System – Understanding New SMS Implications for Your Airport	Room 146B
	• What's Up with the Accreditation Program and What Has Remained Constant?	Room 145A
	• Getting a Bigger Slice of the GA Pie – Washington Perspective on the General Aviation Industry	Room 145B
	• Trends in Airline Use and Lease Agreements – Staying Flexible In Today's Economy	Room 146C
5:45-6:15 p.m.	Board Buses for Evening Event at the Udvar – Hazy Center	
6:45-9:30 p.m.	Evening Event at Udvar – Hazy Center	

MONDAY, JUNE 11

**All sessions will be held at the Washington Convention Center unless otherwise noted. All meeting rooms are located on Street or Third Levels*

7:30 a.m.-7 p.m.	Registration	Concourse A
7:30-8:30 a.m.	Breakfast with the Exhibitors	Hall A

7:30-8:45 a.m.	AAAE Committee Meetings	
	• Information Technology	Room 147B
	• Small Commercial Service Airports	Room 149A
8:45-9:15 a.m.	Official Conference Opening Ceremonies	Ballroom A/B
9:15-10:30 a.m.	Opening Session	Ballroom A/B
10:30-11:30 a.m.	Visit with the Exhibitors and Refreshment Break	Hall A
Noon-1:30 p.m.	Foundation Benefit Luncheon	Ballroom A/B
1:30-3 p.m.	AAAE Transportation Security Services Committee Meeting	Room 146A
1:30-3:30 p.m.	Visit with the Exhibitors	Hall A
2-3 p.m.	2007 National Airports Conference (NAC) Committee Meeting	Room 144C
2:30-3:30 p.m.	Refreshment Break with the Exhibitors	Hall A
3:30-4:30 p.m.	Concurrent Sessions	
	• Registered Traveler Program – RT: Convenience For Travelers, Opportunities for Airports	Room 146A
	• Innovative Terminal Concessions and Retailing Trends – Airport Shopping Experience Reaches New Heights	Room 146C
	• Construction Project Management – Overseeing Hard Hats and Concrete	Room 145A
	• Panel of Airline Planners – Solving the Route Map Puzzle	Room 146B
	• The ABCs of ATC – Long- Term ATC Modernization	Room 145B
5-7 p.m.	Corporate Appreciation Reception with Exhibitors	Hall A

TUESDAY, JUNE 12

**All sessions will be held at the Washington Convention Center unless otherwise noted. All meeting rooms are located on Street or Third Levels*

7:30-8:45 a.m.	AAAE Committee Meetings	
	• Diversity	Room 144A
	• Military Relations	Room 147A
	• Training	Room 144B
8 a.m.-12:30 p.m.	Registration	Concourse A
8 a.m.-12:30 p.m.	Exhibit Hall Open	Hall A
8-9 a.m.	Breakfast with the Exhibitors	Hall A
9-9:30 a.m.	General Session	Ballroom A/B
9:30-10 a.m.	General Session	Ballroom A/B
10-11 a.m.	Refreshment Break with the Exhibitors	Hall A
10 a.m.- 12:30 p.m.	Final Exhibit Hall Hours	Hall A
10:15-11:45 a.m.	AAAE Academic/Student Chapters Workshop (open to all attendees)	Room 147 B
10:30-11:30 a.m.	AAAE Foundation Hour Prize Drawings	Hall A
10:30-11:30 a.m.	U.S. Contract Tower Association General Membership Meeting	Room 146A
11:30 a.m.- 12:30 p.m.	Luncheon with the Exhibitors	Hall A
Noon	Board buses for Golf Tournament at the Reston National Golf Course	
1:30-6:30 p.m.	Golf Tournament at the Reston National Golf Course	
12:30 p.m.	Bus loading for Airfield Tour	
12:45-4:45 p.m.	Metropolitan Washington Airports Authority Airfield Tour	
1-2:30 p.m.	Roundtable Discussions	

	• TSA Roundtable Discussion – Face to Face with TSA Policy Leaders	Room 146A
	• FAA Roundtable Discussion – Face to Face with FAA Policy Leaders	Room 146B
	• FAA Design Competition Panel	Room 146C
1-4:30 p.m.	Capitol Hill Meetings	
1 p.m.	Bus loading for Art in Architecture Tour	
1:15-3:45 p.m.	Metropolitan Washington Airports Authority Art in Architecture Tour	

WEDNESDAY, JUNE 13

**All sessions will be held at the Grand Hyatt Washington*

8 a.m.-3 p.m.	Registration	Independence Foyer
8-9:30 a.m.	AAAE Executive Business Breakfast	Independence Ballroom
9:30-10:30 a.m.	Concurrent Sessions	
	• Screening Checkpoint Technologies – How Will Technology Change the Customer Experience?	Constitution A
	• Aviation Ground Handling Issues – New Solutions To Resolve Old Problems	Constitution B/B Corridor
	• Partnering with Local Chambers/Economic Development Orga- nizations/Convention Bureaus to Attract Air Service – Capturing New Air Service By Creating a Unified Strategy	Constitution CDE
	• Wall Street View of the Airline Industry – Bankruptcies to Mergers: A New Airline Industry Emerges	Farragut/Lafayette
10:30-11 a.m.	Refreshment Break	Constitution Foyer
11 a.m.-Noon	Concurrent Sessions	
	• Emerging Baggage EDS Technologies – New Strategies To Ease Delays, Errors	Constitution A
	• Being Proactive and Prepared – GA Airport Security/Safety Update	Constitution B/B Corridor
	• Customer Service Challenges at Airports – Customers First Makes Airports Number One	Farragut/Lafayette
	• Airport Master Planning Trends – Drafting the Future	Franklin/McPherson
	• Panel of Airline Properties Reps – Deal or No Deal	Constitution CDE
Noon-2 p.m.	AAAE Awards Luncheon	Independence Ballroom
2:15-3:15 p.m.	Concurrent Sessions	
	• Federal Inspection Services Update – FIS Changes Ease Lines, Passenger Delays	Constitution A
	• Airport Community Outreach – Creating a Supportive Neighborhood	Constitution B/B Corridor
	• FAA Reauthorization – Debate Heats Up as Expiration of Current Authorization Bill Nears	Constitution CDE
	• Hot Legal Issues – If You Run an Airport You Need a Lawyer	Franklin/McPherson
	• Airport Management Succession – Training Heirs to the Throne	Farragut/Lafayette
3:30-4:30 p.m.	AAAE Board of Directors/ Policy Review Committee Meeting	Wilson/Roosevelt
6-6:45 p.m.	Chair's Reception	Independence Foyer
6:45-9:30 p.m.	79th Annual AAAE Conference Final Banquet	Independence Ballroom
9:30-11 p.m.	Dessert Reception	Constitution Ballroom

2006-2007 AAAE Board of Directors	4
2006-2007 AAAE Policy Review Committee	4
AAAE Chapter Presidents	4
USCTA Policy Board.....	4
2006-2007 IAAE Board of Directors and Meeting Schedule.....	5
AAAE Committee Chairs.....	5
AAAE Chair's Welcome.....	6
Conference Chair's Welcome.....	7
Registration and Conference Information	8
Future AAAE Conferences	8
AAAE Showcase and Conference Highlights	9
Conference Program	10-16
Spouse/Guest Program.....	17
Washington Convention Center and Grand Hyatt Meeting Rooms	18
Washington Convention Center Exhibit Hall Floor Plan.....	19
Participating Companies.....	20-21
Where to Find (Exhibitors by Product or Company).	22-23
Conference Sponsors and Angels	24-25
Sponsor Directory.....	26-29
Distinguished Service Award (DSA) Winners	30
New AAAE Accredited Members	30
Foundation Benefit Luncheon and Prize Drawings	31
Conference Committee and MWAA Board of Directors.....	31
Airport Magazine Annual Conference Issue Advertisers.....	32
AAAE Past Presidents/Chairs	33

AAAE Board of Directors, PRC, Chapter Presidents, and USCTA Policy Board

2006-2007 AAAE BOARD OF DIRECTORS

CHAIR

Elaine Roberts, A.A.E.—*Columbus, Ohio*

FIRST VICE CHAIR

Krys T. Bart, A.A.E.—*Reno, Nevada*

SECOND VICE CHAIR

James P. Elwood, A.A.E.—*Aspen, Colorado*

SECRETARY/TREASURER

John K. Duval, A.A.E.—*Beverly, Massachusetts*

FIRST PAST CHAIR

R. Lowell Pratte, A.A.E.—*Louisville, Kentucky*

SECOND PAST CHAIR

William G. Barkhauer, A.A.E.—*Morristown, New Jersey*

BOARD OF DIRECTORS

Steven J. Adams, Jr., A.A.E.—*Manchester, New Hampshire*

Lori L. Beckman, A.A.E.—*Denver, Colorado*

James E. Bennett, A.A.E.—*Washington, D.C.*

Randall D. Berg, A.A.E.—*Salt Lake City, Utah*

Benjamin R. DeCosta, A.A.E.—*Atlanta, Georgia*

Kevin A. Dillon, A.A.E.—*Manchester, New Hampshire*

Linda G. Frankl, A.A.E.—*Columbus, Ohio*

Michael J. Haney, A.A.E.—*Moline, Illinois*

Gary L. Johnson, C.M.—*Stillwater, Oklahoma*

Paula Jordan, A.A.E.—*DFW Airport, Texas*

Alex M. Kashani, A.A.E.—*Washington, D.C.*

Parker W. McClellan, Jr., A.A.E.—*Orlando, Florida*

Robert P. Olislagers, A.A.E.—*Englewood, Colorado*

Jeanne M. Olivier, A.A.E.—*Baghdad, Iraq*

Lisa A. Pyles, A.A.E.—*Addison, Texas*

Gary T. Rice, A.A.E.—*Santa Maria, California*

PRESIDENT

Charles M. Barclay, A.A.E.—*Alexandria, Virginia*

2006-2007 AAAE POLICY REVIEW COMMITTEE

Thella F. Bowens—*San Diego, California*

Mark P. Brewer, A.A.E.—*Warwick, Rhode Island*

Timothy L. Campbell, A.A.E.—*BWI Airport, Maryland*

Cheryl D. Cohen-Vader, C.M.—*Denver, Colorado*

Larry D. Cox, A.A.E.—*Memphis, Tennessee*

Alfonso Denson, A.A.E.—*Birmingham, Alabama*

Kent G. George, A.A.E.—*Pittsburgh, Pennsylvania*

Michael A. Gobb, A.A.E.—*Lexington, Kentucky*

Charles J. Isdell, A.A.E.—*Philadelphia, Pennsylvania*

Thomas J. Kinton, Jr.—*East Boston, Massachusetts*

Mark D. Kranenburg, A.A.E.—*Oklahoma City, Oklahoma*

Lynn F. Kusy C.M., C.A.E.—*Mesa, Arizona*

Erin M. O'Donnell—*Chicago, Illinois*

Morton V. Plumb, Jr.—*Anchorage, Alaska*

Mark M. Reis—*Seattle, Washington*

Maureen S. Riley—*Salt Lake City, Utah*

Lester W. Robinson—*Detroit, Michigan*

Ricky D. Smith—*Cleveland, Ohio*

James R. Smith, A.A.E.—*Newport News, Virginia*

Mark H. Webb—*San Antonio, Texas*

AAAE CHAPTER PRESIDENTS

GREAT LAKES CHAPTER

Robert H. Working, A.A.E.—*Evansville, Indiana*

NORTHEAST CHAPTER

Bradley D. Penrod, A.A.E.—*Pittsburgh, Pennsylvania*

NORTHWEST CHAPTER

Bern E. Case, A.A.E.—*Medford, Oregon*

SOUTHEAST CHAPTER

David N. Edwards, Jr., A.A.E.—*Fletcher, North Carolina*

SOUTH CENTRAL CHAPTER

Gary L. Johnson, C.M.—*Stillwater, Oklahoma*

SOUTHWEST CHAPTER

Gary T. Rice, A.A.E.—*Santa Maria, California*

Chapter Presidents are also members of the Policy Review Committee.

U.S. CONTRACT TOWER ASSOCIATION (USCTA) POLICY BOARD

CHAIR

Timothy F. Rogers, A.A.E.—*Salina, Kansas*

BOARD OF DIRECTORS

Tim Abberton, *Canberra, Australia*

Richard R. Baird, *Hailey, Idaho*

Robert L. Bryant, A.A.E., *Salisbury, Maryland*

David A. Byers, AICP, C.M., *Daytona Beach, Florida*

Russell E. Chandler, *Jacksonville, Florida*

Stephen T. Christmas, *North Charleston, South Carolina*

Shane L. Cordes, *Overland Park, Kansas*

Charles H. Dove, *Manassas, Virginia*

Scott R. Driver, *Tucson, Arizona*

Steven M. Harvey, *Lake Charles, Los Angeles*

Gary L. Johnson, C.M., *Stillwater, Oklahoma*

Keith D. Kaspari, *Gwinn, Michigan*

Lynn F. Kusy, C.M., C.A.E., *Mesa, Arizona*

Brian M. Lally, P.E., *Cocoa Beach, Florida*

Richard K. Lewis, *Concord, North Carolina*

Jerry O'Sullivan, A.A.E., *Lewisburg, West Virginia*

Timothy F. Rogers, A.A.E., *Salina, Kansas*

Christopher A. Rozansky, C.M., *McKinney, Texas*

Theodore D. Soliday, C.M., *Naples, Florida*

Steve Stockam, *Joplin, Missouri*

Walter B. Strong, Jr., A.A.E., *Norman, Oklahoma*

Tim E. Whitman, *Denton, Texas*

INTERNATIONAL ASSOCIATION
OF AIRPORT EXECUTIVES BOARD
OF DIRECTORS

CHAIR

Timothy L. Campbell, A.A.E.—*BWI Airport, MD, USA*

BOARD OF DIRECTORS

Bonnie A. Allin, A.A.E.—*Tucson, Arizona, USA*
 William G. Barkhauer, A.A.E.—*Morristown, New Jersey, USA*
 Krys T. Bart, A.A.E.—*Reno, Nevada, USA*
 James E. Bennett, A.A.E.—*Washington, D.C., USA*
 Frank Blas—*Tamuning, Guam*
 Robert L. Bogan, A.A.E.—*Morristown, New Jersey, USA*
 Mark P. Brewer, A.A.E.—*Warwick, Rhode Island, USA*
 Denton A. Campbell, A.A.E.—*Montego Bay, Jamaica*
 Rasmus Christiansen—*Kastrup, Denmark*
 Larry D. Cox, A.A.E.—*Memphis, Tennessee, USA*
 Alfonso Denson, A.A.E.—*Birmingham, Alabama, USA*
 Gabriel Dumitrescu—*Bucharest, Romania*
 John K. Duval, A.A.E.—*Beverly, Massachusetts, USA*
 James P. Elwood, A.A.E.—*Aspen, Colorado, USA*
 Gerald P. FitzGerald, A.A.E.—*New Fairfield, Connecticut, USA*
 Kent G. George, A.A.E.—*Pittsburgh, Pennsylvania, USA*
 Michael A. Gobb, A.A.E.—*Lexington, Kentucky, USA*
 Alfred J. Graser, A.A.E.—*New York, New York, USA*
 Henryk Jelonkiewicz—*Warszawa, Poland*
 Kelly L. Johnson, A.A.E.—*Bentonville, Arkansas, USA*
 James A. Koslosky, A.A.E.—*Grand Rapids, Michigan, USA*
 Patricia R. Krall—*Boston, Massachusetts, USA*
 Bosko Markovic—*Zagreb, Croatia*
 James L. Morasch, A.A.E.—*Pasco, Washington, USA*
 George Y. Paldi—*Sukoro, Hungary*
 Chang-Gyu Park—*Inchon City, South Korea*
 Tonci Peovic—*Dubrovnik, Croatia*
 R. Lowell Pratte, A.A.E.—*Louisville, Kentucky, USA*
 Elaine Roberts, A.A.E.—*Columbus, Ohio, USA*
 Stefan Runcan—*Targu Mures, Romania*
 Petr Rychetsky—*Prague, Czech Republic*
 Richard Schano—*Salzburg, Austria*
 Roger Sellick, A.A.E.—*Kelowna, British Columbia, Canada*
 James R. Smith, A.A.E.—*Newport News, Virginia, USA*
 Eric D. Tolton—*Toronto, Ontario, Canada*
 Tolga R. Turgut—*Istanbul, Turkey*

AAAE COMMITTEE CHAIRS FOR 2006-2007

2007 Annual Conference—James E. Bennett, A.A.E., *Conference Host*
2007 NAC—Mark Brewer, A.A.E., *Chair*, and Randall Berg, A.A.E., *Vice Chair*
AAAE Diversity—Levert Hood, *Chair*
Academic Relations—Jeanne Olivier, A.A.E., *Chair*, and Steven J. Adams, A.A.E., *Vice Chair*
Airline Economics and Air Service—Bruce Carter, A.A.E., *Chair*, and Robert W. O'Brien, A.A.E., *Vice Chair*
Airport Training—Bradley D. Penrod, A.A.E., *Chair*
Audit—Scott Brockman, A.A.E., *Chair*
Aviation Ground Service Association—Bruce Carter, A.A.E., *Chair*
Board of Examiners—Thomas H. Binford, A.A.E., *Chair*
Chapter Presidents—Elaine Roberts, A.A.E., *Chair*
Environmental Services—Catherine Wetherell, *Chair*
Ethics—R. Lowell Pratte, A.A.E., *Chair*
Finance and Administration—Brian Picardat, A.A.E., *Chair*
Foundation—Kelly Johnson, A.A.E., *Chair*
General Aviation Airports—Robert Orlislagers, A.A.E., *Chair*
Information Technology—Lance Lyttle, *Chair*
International Association of Airport Executives—Timothy L. Campbell, A.A.E., *Chair*
Military Relations—Andy Rivera, A.A.E., *Chair*
Operations/Safety/Planning—Alvin L. Stuart, A.A.E., and Michael Cheyne, A.A.E., *Co-Chairs*
Small Commercial Service Airports—Thomas P. Nolan, A.A.E., *Chair*
Technical Services—C.T. (Skip) Miller, A.A.E., *Chair*, and Alex Kashani, A.A.E., *Vice Chair*
Transportation Security Services—Christopher V. Browne, C.M., *Chair*, and Linda Frankl, A.A.E., *Vice Chair*
U.S. Contract Tower Association—Timothy F. Rogers, A.A.E., *Chair*

2007 International AAAE/IAAE Meetings

July 2-4 Brussels, Belgium *Conrad Brussels*
U.S./Europe Aviation Security Policy Summit
 sponsored by European Commission, European Civil Aviation Conference, U.S. Transportation Security Administration, AAAE, Airports Council International – Europe, IAAE and APCO Worldwide

August 26-28 St. Petersburg, Russia, *Hotel Astoria*
AAAE/IAAE International Airport Security Technology Conference
 sponsored by AAAE, IAAE, Pulkovo Airport St. Petersburg, U.S. Commercial Service Office – St. Petersburg, Russia, and Aeroflot Russian Airlines

October 14-16 Wroclaw, Poland *Sofitel Victoria*
U.S.-Europe Airport Commercial Development Conference
 sponsored by AAAE, IAAE and Airport Wroclaw

November 11-13 Munich, Germany
AAAE/IAAE 13th Annual Central Europe/ U.S. Airport Issues Conference
 sponsored by Hungarian Air Traffic and Airport Administration, U.S. Embassy-Hungary, AAAE and IAAE

For further information, contact Spencer Dickerson at (703) 824-0500, Ext. 130, or e-mail, spencer.dickerson@aaae.org.



AMERICAN ASSOCIATION
OF AIRPORT EXECUTIVES

To All Our Attendees:

Welcome to Washington, D.C., and the 79th Annual AAAE Conference and Exposition. This is the first time in AAAE's history that the annual conference has been held in our nation's capital, where major decisions are being made every day that impact airports across the country. Key discussions are underway in Congress right now on FAA reauthorization, AIP and PFC funding, security issues and many other important issues facing our industry today. This week will provide you with an opportunity to meet with your members of Congress and to discuss how these key issues affect your airport.

One of the most valuable aspects of the Annual AAAE Conference and Exposition is the opportunity for face-to-face networking with colleagues in the aviation industry. Add to that the opportunity to spend time with old friends and meet new ones, as well as create professional partnerships, and you have a can't-miss formula for a successful conference experience!

There are many people we must thank for bringing it all together, but I especially want to extend my personal thanks as well as those of our Association to conference host Jim Bennett, A.A.E., President and CEO of the Metropolitan Washington Airports Authority. Jim and the MWAA staff have been working long and hard to make sure that each and every attendee will have an experience unequalled in our industry. Our nation's capital has so much to offer, so please take the time to explore the many places of local and national interest—AFTER you attend the informative business sessions, of course!

I would be remiss if I did not recognize the continuing contributions of the AAAE Board of Directors, Policy Review Committee, Chapter Presidents, members of the Board of Examiners and all the Committee Chairs. These individuals do so much throughout the year, volunteering their time, energy and expertise to ensure that AAAE continues to thrive and prosper. I would also like to give special thanks to the Accreditation Value Task Force members for their time and valuable input during this past year, which resulted in a Board-adopted report with numerous recommendations for enhancing the value and benefits of being an Accredited Airport Executive.

I also want to thank Conference Program Chair Jonathon Gaffney, as well as Conference Planning Chair Margaret A. Bishop, along with the entire Conference Committee, for all their hard work and effort. The committee has put together an extensive and comprehensive program with more than 30 business sessions, designed to address the many challenges that continue to face our industry in the post-9/11 environment. You will reap tremendous benefits by attending as many of these sessions as possible, and other attendees will profit from the thoughts and ideas you bring to the table.

The annual AAAE Exposition, to be held at the Washington Convention Center on Sunday, Monday and Tuesday, will be the largest such airport exposition in the world. This year, more than 200 companies will showcase an amazing variety of state-of-the-art airport products and services. Please take the time to visit with the exhibitors, and be sure to thank our many corporate members for their generous financial support of AAAE.

Last, but certainly not least, I want to thank the membership for giving me the honor and privilege of serving as your Chair during the past year. I am particularly appreciative of the wonderful hospitality I received as I traveled throughout the United States, as well as around the world, representing AAAE. Thank you for your vote of confidence and support during this past year.

Sincerely,

Elaine Roberts, A.A.E.
AAAE Chair



METROPOLITAN WASHINGTON
AIRPORTS AUTHORITY

Dear Friends and Colleagues:

The Metropolitan Washington Airports Authority (Airports Authority) is proud to host the 79th Annual Conference and Exposition of the American Association of Airport Executives in Washington, D.C., from June 10-13, 2007. On behalf of the Airports Authority Board and staff, I'd like to welcome you to the Capital Region and to our airports, Ronald Reagan Washington National and Washington Dulles International. AAAE and the Airports Authority have planned an excellent conference program and exciting events for delegates, sponsors, exhibitors and their guests.

The Airports Authority was established by legislation of the Commonwealth of Virginia State Legislature and the District of Columbia City Council to operate Reagan National and Dulles and address the region's long-term air transportation needs. Together, our two airports served nearly 42 million passengers in 2006; of that number, over 5 million were international passengers using our facilities at Dulles.

Growth has been the operative word at Dulles, and if you are traveling through that airport, you will likely see signs of the considerable construction that is part of our D2, Dulles Development program. The D2 program includes the recent opening of a new ATC tower, expansion of our Concourse B, construction of an entirely new security mezzanine beneath the Main Terminal and an entirely new passenger conveyance system called Aero Train. If you have time, take a look at the exhibit near baggage carousel #3 to learn more about Aero Train.

At Reagan National, improvements continue as we are currently constructing a new consolidated communications center with an integrated emergency operations center. In addition, we will soon be adding 1,300 additional public parking spaces by constructing another level to each of our parking garages. We will also be starting construction on a new ARFF facility as well as expanding our corporate office building.

At this year's AAAE conference, you'll have the opportunity to hear presentations from a wide range of aviation experts and special guest speakers covering the important issues facing the aviation industry today and into the future.

Please be sure to join us for the host event on Sunday evening at the Smithsonian National Air and Space Museum's Udvar-Hazy Center located at Dulles. This is a fantastic facility with even more fantastic aircraft that spans the history of aviation.

During your visit, I encourage you to enjoy Washington, D.C., and the attractions in nearby Virginia and Maryland. Our region offers a wide variety of things to see and do, appealing to guests from around the world.

Thank you for participating in our Capital Experience this year. We hope you enjoy the AAAE Annual Conference and Exposition and your visit to our Capital Region.

Best regards,

James E. Bennett, A.A.E.
President and Chief Executive Officer
Metropolitan Washington Airports Authority

Conference Information

REGISTRATION

Business sessions, breakfasts, luncheons and the exposition will take place Sunday through Tuesday, June 10-12, at the Washington Convention Center. Wednesday's breakfast, business sessions, luncheon, final banquet, as well as the spouse/guest orientation breakfast and tour departures will take place at the Grand Hyatt Washington Hotel.

DELEGATE REGISTRATION HOURS:

Saturday, June 9	2-5 p.m.
Sunday, June 10	8 a.m.-4:45 p.m.
Monday, June 11	7:30 a.m.-7 p.m.
Tuesday, June 12	8 a.m.-12:30 p.m.
Wednesday, June 13	8 a.m.-3 p.m.

ABOUT YOUR BADGE

The only thing you need to participate in the conference and exposition will be your badge, which has been color-coded for easy identification. Be sure to wear it at all times. Not only does it serve as your introduction to the people you meet, but it is also necessary to gain access to all events.

Orange	Accredited Airport Executive (A.A.E.)
Navy Blue	Delegate
Light Blue	Spouse/Guest
Red	Conference Lite (includes all exhibit hall functions and business sessions. Excludes luncheons on June 11 and 13; the Sunday evening event at the Udvar-Hazy Center, and the final banquet on June 13)
Green	Exhibitor (includes exhibit hall functions, business sessions and Sunday evening event)
Pink	Press

As a fully paid registrant (orange or navy blue badge), you are entitled to attend all business sessions, the exposition, three breakfasts, four luncheons, two receptions, the final banquet and Sunday evening's event at the Udvar-Hazy Center. As a fully paid spouse/guest (light blue badge), you are entitled to attend the opening luncheon in the exhibit hall, the breakfast and orientation program on Monday morning, Sunday evening's event and the final banquet.

79TH ANNUAL FINAL BANQUET

TICKET EXCHANGE

As a fully paid delegate (orange or navy blue badge) or spouse/guest (light blue badge), you will receive a voucher for the final banquet with your registration materials. You need to exchange that voucher for a ticket at the Banquet Exchange Counter, located in the AAAE Registration Area in Concourse A at the Washington Convention Center before noon on Tuesday, June 12. After that time, you may exchange your ticket until 3 p.m. on Wednesday, June 13 at the registration desk at the Grand Hyatt Washington. Plan to collect vouchers from those people you wish to sit with and exchange them at the same time so that you will be sitting at the same table. The maximum number of people at each table is 10. Be sure to exchange your ticket as early as possible—this will guarantee you'll be sitting with your friends!

AAAE EXHIBIT HALL HOURS

Sunday, June 10	12-4:45 p.m.
Monday, June 11	7:30 a.m.-Noon, 1:30-3:30 p.m., 5-7 p.m.
Tuesday, June 12	8 a.m.-12:30 p.m.

COMPLIMENTARY INTERNET ACCESS IN THE EXHIBIT HALL!

AAAE will provide complimentary Internet access for all conference attendees Sunday, June 10-Tuesday, June 12 in the exhibit hall. The Internet kiosks will be located in Clear/Verified Identity Pass' Booth #411. The Clear* Registered Traveler program allows travelers, who are pre-screened, access to a separate, faster line through airport security for an annual fee of \$99.95. Visit www.flyclear.com for information on participating airports and to enroll online.

WHO'S WHO IN AAAE? YOU ARE!

Remember the AAAE Membership Directory of years gone by—with photos of members and brief biographies? We offer that format in our on-line AAAE Membership Directory at www.aaae.org/membersdirectory/. The directory allows you to view pictures of participating AAAE members and provides brief background information. If your photo and biography are not currently on-line, be sure to stop by the AAAE Showcase and drop off your completed "Who's Who in AAAE" flier. Specific information can be found in your registration bag.

AAAE ANNUAL CONFERENCE AND EXPOSITION YEAR DATE LOCATION

2008	June 8-11	New Orleans, Louisiana
2009	June 14-17	Philadelphia, Pennsylvania
2010	May 16-19	Dallas/Fort Worth, Texas
2011	May 15-18	Atlanta, Georgia

AAAE NATIONAL AIRPORTS CONFERENCE (NAC) YEAR DATE LOCATION

2007	September 16-18	Tucson, Arizona
2008	September 7-9	Reno, Nevada

The AAAE Showcase in Booth #527 – so much to see and learn!

Visit the AAAE Showcase where staff members will be on hand to assist you with your questions regarding the annual conference, AAAE and its many products and services. Network with your fellow colleagues and AAAE members, watch interactive training demos and live coverage of the conference from the AETV studio and more!

AETV Studio

Watch the live interviews on four huge screens that will be hanging high over the AAAE Showcase or view the action right there in person at the AAAE studio. You'll see conference speakers, vendors and members of the AAAE leadership team bringing you news and updates. Don't forget, the AAAE studio is where the prize drawings for the Foundation Hour and other prizes throughout the show are announced. You may be the next lucky winner!

Training and Professional Development

AAAE staff will be on hand to discuss and demonstrate the many training tools offered through the association, such as on-site training courses, Interactive Employee Training (IET), ACE programs, ARFF, accreditation and advancement of your career. Experience the new ANTN Digicast Online that offers top notch training and news videos on the Internet. Don't miss out on the opportunity to see everything, all in one place!

Conference Services

Find out if you have won one of the many prizes that will be given away throughout the exhibit hall. Need to find a vendor on the show floor? Use the "Locate an Exhibitor" function on the computers in the AAAE Showcase to find out where the vendor is located in the exhibit hall. Please give us your feedback!

Products and Services

Come and see the many products and services that AAAE has on display. Sample surveys, meetings information, news items, websites, job descriptions, career center, training and professional development tools are just a few of the offerings you'll see.

The Daily Dispatch

The Daily Dispatch is the official daily electronic newsletter covering the 79th Annual AAAE Conference and Exposition. The free-of-charge publication, produced by the staffs of Airport Magazine and Airport Report Express, will be emailed out soon after the close of each show business day. Each issue will include short features, news briefs and recaps of the day's events. Sign up for the Daily Dispatch at www.aaae.org/dispatch. If you have news to contribute to the Daily Dispatch, bring it to Airport Magazine's Booth (#729) or email it to magazine@aaae.org.

Sponsored by The LPA Group (Saturday), Transcore (Sunday), PBS&J (Monday), Honeywell International (Tuesday) and Jacobs Consultancy (Wednesday).

As a special service for conference delegates, we are running highlights from the Aviation News Today show, other ANTN programs and conference information on the hotel television networks on a continuous basis this week. You can see this on Channel 9 at the Grand Hyatt Washington and Channel 38 at the Renaissance D.C. as well as in the AAAE Showcase in the exhibit hall.

Conference Program

SATURDAY, JUNE 9

**All sessions will be held at the Washington Convention Center*

8 a.m.-5 p.m.	Exhibitor Registration	Concourse A
8 a.m.-12 p.m.	AAAAE Board of Directors/ Policy Review Committee Meeting	Constitution A/B Grand Hyatt Washington
2-5 p.m.	Delegate Registration	Concourse A

SUNDAY, JUNE 10

**All sessions will be held at the Washington Convention Center unless otherwise noted. All meeting rooms are located on the Street or Third Level.*

6 a.m.-4:45 p.m.	Exhibitor Registration	Concourse A
8 a.m.- 4:45 p.m.	Delegate Registration	Concourse A
9 a.m.-5 p.m.	AAAAE Accreditation Examinations	Grand Hyatt Washington
9-10:15 a.m.	AAAAE Chapter Meetings	
	Great Lakes Chapter	Room 144A
	Robert H. Working, A.A.E., <i>President</i>	
	Northeast Chapter	Room 144B
	Bradley D. Penrod, A.A.E., <i>President</i>	
	Northwest Chapter	Room 144C
	Bern E. Case, A.A.E., <i>President</i>	
	South Central Chapter	Room 147A
	Gary L. Johnson, C.M., <i>President</i>	
	Southeast Chapter	Room 147B
	David N. Edwards, A.A.E., <i>President</i>	
	Southwest Chapter	Room 146A
	Gary T. Rice, A.A.E., <i>President</i>	
9:30-10 a.m.	Exhibitors Meeting	Room 146A
10:30 a.m.-Noon	AAAAE Executive Business Meeting (open to all members) <i>Sponsored by Phoenix International Airport</i>	Ballroom A/B
Noon-1:30 p.m.	Official Opening of the Exhibit Hall and Luncheon <i>Co-sponsored by Berkley Aviation, LLC, Faber Coe & Gregg, Jacobs Engineering, Reno-Tahoe Airport Authority and URS Corporation</i>	Hall A
12:30-2:30 p.m.	International Association of Airport Executives Board Meeting and Luncheon	Room 147A
1:15-3:15 p.m.	AAAAE Committee Meetings	
	Academic Relations Committee	Room 147B
	Jeanne Olivier, A.A.E., <i>Chair</i> Steven J. Adams, A.A.E., <i>Vice Chair</i>	

Airline Economics and Air Services	Room 143A
Bruce Carter, A.A.E., <i>Chair</i> Robert O'Brien, A.A.E., <i>Vice Chair</i>	
Finance and Administration	Room 144D
Brian Picardat, A.A.E., <i>Chair</i>	
General Aviation	Room 144C
Robert Olislagers, A.A.E., <i>Chair</i>	
Foundation	Room 144A
Kelly Johnson, A.A.E., <i>Chair</i>	
Operations, Safety and Planning	Room 146B
Michael Cheync, A.A.E., <i>Co-Chair</i> Alvin L. Stuart, A.A.E., <i>Co-Chair</i>	
Technical Services	Room 145A
Charles (Skip) Miller, A.A.E., <i>Chair</i> Alex Kashani, A.A.E., <i>Vice Chair</i>	

1:30-2:30 p.m.	Airport Board Members and Commissioners Session	Room 146A
----------------	--	-----------

1:30-4:45 p.m.	Exhibit Hall Open	Hall A
----------------	--------------------------	--------

2:30-3:30 p.m.	Refreshment Break with Exhibitors <i>Co-sponsored by Kennedy/Jenks Consultants, Inc. and The Paradise Shops, Inc.</i>	Hall A
----------------	---	--------

3:30-5 p.m.	AAAAE Academic Student Chapters Workshop (open to all attendees)	Room 147B
-------------	--	-----------

- **Extreme Networking: Make the Most of Attending the Annual**
This active seminar covers what you need to know to maximize your networking opportunities at the annual conference, and for your career.
- Moderator: **Jeffrey C. Price, M.A., C.M.**
Leading Edge Strategies

3:45-4:45 p.m.	Concurrent Sessions	
	• Cargo Security Update – Industry Concerns	Room 146A

- Moderator: **Gerald Buckwalter**
*Director of Homeland Security
Northrop Grumman IT*
- Speakers: **Victor Parker**
*Branch Chief, Air Cargo Transportation Sector
Network Management*
U.S. Transportation Security Administration
Douglas Dobie
San Francisco International Airport Campaign Manager
Lawrence Livermore National Laboratory

- **Safety Management System –
Understanding New SMS Implications
For Your Airport**
- Moderator: **Alvin L. Stuart, A.A.E.**
*Superintendent of Airport Operations
Salt Lake City International Airport*

- Speakers: **Darryel Adams**
SMS Project Manager, Airport Certification Division
 U.S. Federal Aviation Administration
- Dr. Chen-Chung Hsin**
Director
 The MITRE Corporation
- **What's Up with the Accreditation Program and What Has Remained Constant?** Room 145A
- Moderator: **Thomas H. Binford, A.A.E.**
Director of Aviation
 Billings Logan International Airport
- Speakers: **Danette M. Bewley, A.A.E.**
Senior Program Manager
 Reno-Tahoe International Airport
- Mark Kranenburg, A.A.E.**
Director of Airports
 Will Rogers World Airport
- David R. Ulane, A.A.E.**
Assistant Aviation Director
 Aspen/Pitkin County Airport
- **Getting a Bigger Slice of the GA Pie – Washington Perspective on the General Aviation Industry** Room 145B
- Moderator: **Alfred Pollard, A.A.E.**
Director
 Martin State Airport
- Speakers: **Andrew Cebula**
Executive Vice President, Government Affairs
 Aircraft Owners & Pilots Association
- Stan Mackiewicz**
Representative, Government and Industry Affairs
 National Air Transportation Association
- Lisa Piccione**
Senior Vice President, Government Affairs
 National Business Aviation Association
- Brian Riley**
Vice President, Government Affairs
 General Aviation Manufacturers Association
- **Trends in Airline Use and Lease Agreements – “Staying Flexible In Today’s Economy”** Room 146C
- Moderator: **Delores J. Singletary**
Project Manager/Vice President
 O.R. Colan Associates, Inc.
- Speakers: **Angela Gittens**
Vice President
 HNTB Corporation
- Margaret E. McKeough**
Executive Vice President and Chief Operating Officer
 Metropolitan Washington Airports Authority
- Tracy Thompson**
Director
 Jacobs Consultancy

- 5:45-6:15 p.m. **Board Buses for Evening Event at Udvar-Hazy Center**
 Buses load at 5:45 p.m. in the Convention Center Parking Lot (across the street from the Grand Hyatt and Renaissance D.C. hotels)
- 6:45-9:30 p.m. **Evening Event at Udvar-Hazy Center**
 Return buses start departing at 8:30 p.m. and will drop off attendees at the Grant Hyatt and Renaissance D.C. hotels.
Transportation and bus hospitality sponsored by Parsons Management Consultants, a joint venture of Parsons Corporation, DMJM Aviation, PB Americas, Inc., and Delon Hampton and Associates, Chartered.
In conjunction with the MWWA Capital Club Sponsors: Alpha Corporation, Amman & Whitney, Giuliani Associates Architects, Inc., Hogan & Harson, LLP, Infrastructure Management Group, The Lane Construction Company, a joint venture of Parsons Corporation, DMJM Aviation, PB Americas, Inc., and Delon Hampton and Associates, Chartered, URS Corporation and Washington Airports Task Force

Join MWWA for a sumptuous reception and high-flying entertainment as marvels of the aviation history soar overhead at the Steven F. Udvar-Hazy Center. Located near Washington Dulles International Airport, the Udvar-Hazy Center is the companion facility to the National Air & Space Museum on the National Mall. You can walk among aircraft and small artifacts in display cases and view aircraft hanging from the arched ceiling on elevated skywalks. Among the aviation artifacts on display are the Lockheed SR-71 Blackbird, the fastest jet in the world; the Boeing Dash 80, the prototype of the 707; the Boeing B-29 Superfortress Enola Gay, and the deHavilland Chipmunk aerobatic airplane. The space hangar displays hundreds of famous spacecraft, rockets, satellites and space-related small artifacts. The centerpiece of the space hangar is the Space Shuttle Enterprise. In addition, the Udvar-Hazy Center's observation tower provides an excellent location from which visitors can watch air traffic at Dulles Airport. This will be a fantastic evening event for all fully registered attendees, exhibitors and spouse/guests only! **(Registration badge and ticket will be required for entry. Attire for the event is casual.)**

MONDAY, JUNE 11

**All sessions will be held at the Washington Convention Center unless otherwise noted. All meeting rooms are located on Street or Third Levels.*

- 7:30 a.m.-7 p.m. **Registration** Concourse A
- 7:30-8:30 a.m. **Breakfast with the Exhibitors** Hall A
Co-sponsored by Hanson Professional Services, HDS Retail North America and The LPA Group Inc.
- 7:30-8:45 a.m. **AAAE Committee Meetings**
- Information Technology** Room 144A
 Lance Lytle, *Chair*
 Steven J. Adams, A.A.E., *Vice Chair*
- Small Commercial Service Airports** Room 14B
 Thomas P. Nolan, A.A.E., *Chair*

Conference Program

8:45-9:15 a.m. Official Conference Opening Ceremonies	Ballroom A/B	3:30-4:30 p.m. Concurrent Sessions	Room 146A
<p>Presiding: Elaine Roberts, A.A.E. <i>AAAE Chair</i></p> <p>Mame Reiley <i>Chairman</i> Metropolitan Washington Airports Authority</p> <p>The Honorable H.R. Crawford <i>Vice Chairman</i> Metropolitan Washington Airports Authority</p> <p>Vincent Gray <i>Chair</i> Council of the District of Columbia</p> <p>James E. Bennett, A.A.E. <i>President and CEO</i> Metropolitan Washington Airports Authority</p>		<ul style="list-style-type: none"> • Registered Traveler Program – RT: Convenience For Travelers, Opportunities for Airports <p>Moderator: Carter Morris <i>Senior Vice President, Transportation Security Policy</i> American Association of Airport Executives</p> <p>Speakers: Bill Conners <i>Executive Director and Chief Operating Officer</i> National Business Travel Association</p> <p>John Martinez <i>Director, Registered Traveler Program Office</i> U.S. Transportation Security Administration</p> <p>Evert Meyer, Ph.D. <i>Principal</i> Booz Allen Hamilton</p>	
9:15-10:30 a.m. Opening Session	Ballroom A/B	<ul style="list-style-type: none"> • Innovative Terminal Concessions and Retailing Trends – Airport Shopping Experience Reaches New Heights 	Room 146C
<p><i>Co-sponsored by Delaware North Companies Travel Hospitality Services, DMJM Aviation/AECOM, FirstLine Transportation Security and Heery International</i></p>		<p>Moderator: Margaret E. McKeough <i>Executive Vice President and Chief Operating Officer</i> Metropolitan Washington Airports Authority</p>	
<p>Keynote Speaker: The Honorable James Oberstar (D-MN) <i>Chairman, House Transportation and Infrastructure Committee</i> U.S. House of Representatives</p>		<p>Speakers: Ann Ferraguto <i>Principal Associate</i> Jacobs Consultancy</p> <p>Jack Hemphill <i>Business General Manager</i> Massachusetts Port Authority</p> <p>Ben Mutzabaugh <i>Travel Writer</i> USA Today</p>	
10:30 a.m.-11:30 a.m. Visit with the Exhibitors and Refreshment Break	Hall A	<ul style="list-style-type: none"> • Construction Project Management – Overseeing Hard Hats and Concrete 	Room 145A
<p><i>Co-sponsored by Midwest Air Traffic Control Services Inc., Robinson Aviation (RVA) Inc. and Serco, Inc.</i></p>		<p>Moderator: Scott Hinderman, A.A.E. <i>Director of Operations</i> Fort Wayne-Allen County Airport Authority</p>	
Noon-1:30 p.m. Foundation Benefit Luncheon	Ballroom A/B	<p>Speakers: Philius Angelidos <i>Senior Vice President</i> Alpha Corporation</p> <p>Richard Lloyd <i>Assistant Site Manager</i> Parsons Corporation</p> <p>Angela R. Newland, A.A.E. <i>Vice President, Planning and Engineering Department</i> Columbus Regional Airport Authority</p>	
<p>Keynote Speaker: Bill Diffenderfer <i>Chief Executive Officer</i> Skybus Airlines</p>		<ul style="list-style-type: none"> • Panel of Airline Planners – Solving The Route Map Puzzle 	Room 146B
1:30-3 p.m. AAAE Transportation Security Services Committee Meeting	Room 146A	<p>Moderator: Mark F. Courtney, A.A.E. <i>Airport Director</i> Lynchburg Regional Airport</p>	
<p>Christopher Browne, C.M., Chair Linda Frankl, A.A.E., Vice Chair</p>		<p>Speakers: David Jehn <i>Director, North America Planning</i> United Airlines</p>	
1:30-3:30 p.m. Visit with the Exhibitors	Hall A		
<p>2-3 p.m. 2007 National Airports Conference (NAC) Committee Meeting</p> <p>Mark Brewer, A.A.E., Chair Randall Berg, A.A.E., Vice Chair</p>	Room 144C		
2:30-3:30 p.m. Refreshment Break with the Exhibitors	Hall A		
<p><i>Co-sponsored by DM Airport Developers, Operator of Morristown Municipal Airport, and Hatch Mott McDonald</i></p>			

Kevin P. Healy
Vice President, Planning
 AirTran Airways

• The ABCs of ATC – Long-Term ATC Modernization Room 145B

Moderator: Roddy L. Boggus
Senior Vice President of Aviation
 Gresham, Smith & Partners

Speakers: Doug Arbuckle
Agile Air Traffic System IPT Director
 Joint Planning and Development Office (JPDO)

Matthew Blake
Director of Automation Systems
 Sensis Corporation

Ginger S. Evans, P.E.
Managing Principal, Aviation
 Carter & Burgess, Inc.

David Ford
Vice President of Strategic Programs
 Era

5-7 p.m. Corporate Appreciation Reception with Exhibitors Hall A
Co-sponsored by Delaware North Companies
Travel Hospitality Services, Jacobs Consultancy
and Kimley-Horn and Associates

TUESDAY, JUNE 12

* All sessions will be held at the Washington Convention Center unless otherwise noted. All meeting rooms are located on Street or Third Levels.

7:30-8:45 a.m. AAAE Committee Meetings

Diversity Room 144A
 Levert Hood, *Chair*

Military Relations Room 147A
 Andy Rivera, A.A.E.

Training Room 144B
 Bradley D. Penrod, A.A.E., *Chair*

8 a.m.-12:30 p.m. Registration Concourse A

8 a.m.-12:30 p.m. Exhibit Hall Open Hall A

8-9 a.m. Breakfast with the Exhibitors Hall A
Sponsored by AREAS USA

9-9:30 a.m. General Session Ballroom A/B

Keynote Speaker: David Neeleman Ballroom A/B
Chairman
 JetBlue Airways 

9:30-10 a.m. General Session Ballroom A/B
Co-sponsored by Carter & Burgess, Inc.,
Hudson Group and Memphis-Shelby County
Airport Authority

Keynote Speakers: Tom Schmitt 
CEO, FedEx Global Logistics
& Supply Chair, Senior Vice President
 FedEx Solutions

Arnold Perl 
Chairman
 Memphis-Shelby County
 Airport Authority

10 a.m.-12:30 p.m. Final Exhibit Hall Hours Hall A

10-11 a.m. Refreshment Break with the Exhibitors Hall A
Sponsored by Gresham, Smith & Partners

10:15-11:45 a.m. AAAE Academic/Student Chapters Workshop Room 147 B
 (open to all attendees)

• Planning Your Airport Career the Right Way

Moderator: Chad Nixon
Aviation Director
 McFarland-Johnson, Inc.

Speakers: Robert L. Bogan, A.A.E.
Deputy Director
 Morristown Municipal Airport

John S. Kinney, C.M.
Director of Operations
 Denver International Airport

Jeanne M. Olivier, A.A.E.
 U. S. Dept. of State, Iraq Reconstruction
 Management Office

Thomas M. Rafter, A.A.E.
Airport Director
 Atlantic City International Airport

10:30-11:30 a.m. AAAE Foundation Hour Prize Drawings Hall A
 (must be present to win)

10:30-11:30 a.m. U.S. Contract Tower Association Room 146A
 General Membership Meeting

11:30 a.m.-12:30 p.m. Luncheon with the Exhibitors Hall A
Co-sponsored by Creative Host Services, Inc.
DBA, Ricondo & Associates, Inc. and Skanska
USA Building, Inc.

Noon Golf Tournament at Reston National Golf Course
 Bus loading begins at noon and buses depart promptly
 at 12:15 p.m. from the "L" Street Entrance at the
 Washington Convention Center

1:30-6:30 p.m. Golf Tournament at Reston National Golf Course
Tournament sponsored by Booz Allen Hamilton
Beverage Carts sponsored by ERA and HNTB Corporation
Holes sponsored by Midwest Air Traffic Control Ser-
vices, Inc., Robinson Aviation (RVA), Inc., Serco, Inc.,
SuperShuttle International, and Woodward & Associates

Conference Program

12:30-4:45 p.m. **Metropolitan Washington Airports Authority Airfield Tour**
 Bus loading begins at 12:30 p.m. and buses depart promptly at 12:45 p.m. from the "L" Street Entrance at the Washington Convention Center

1-2:30 p.m. **Roundtable Discussions**

- **TSA Roundtable Discussion – Face to Face with TSA Policy Leaders** Room 146A

Moderator: Carter Morris
*Senior Vice President, Transportation Security Policy
 American Association of Airport Executives*

TSA Speakers: Dana Brown
*Assistant Administrator for Law Enforcement
 and Director of Federal Air Marshal Service*

Mike Golden
*Assistant Administrator for Operational Process
 and Technology, Chief Information Officer
 and Chief Technology Officer*

Francine Kerner
Chief Counsel

Mo McGowan
Assistant Administrator for Security Operations

Charlotte Peed
*Airports Stakeholder for Transportation
 Sector Network Management*

Stephanie Rowe
*Assistant Administrator for Transportation
 Threat Assessment and Credentialing*

John Sammon
*Assistant Administrator for Transportation
 Sector Network Management*

Jeff Sural
Assistant Administrator for Legislative Affairs

- **FAA Roundtable Discussion – Face to Face with FAA Policy Leaders** Room 146B

Moderator: Thomas E. Zoeller
*Vice President, Regulatory Affairs
 American Association of Airport Executives*

FAA Speakers: David L. Bennett
Director, Airport Safety and Standards

Benito DeLeon
Director, Airport Planning and Programming

Catherine M. Lang
Deputy Associate Administrator for Airports

D. Kirk Shaffer
Associate Administrator for Airports

- **FAA Airport Design Competition Panel** Room 146C

Moderators: Mary Sandy
*Director
 Virginia Space Grant Consortium*
 Susan Gardner
*Lead for Competition
 U.S. Federal Aviation Administration*

Award Presenters: Tony Mello
*Acting Vice President of Safety Services
 U.S. Federal Aviation Administration*

D. Kirk Shaffer
*Associate Administrator for Airports
 U.S. Federal Aviation Administration*

Competition Winners: **First Place – Airport Operations and Maintenance Challenge**
*San Jose State University, San Jose, CA – proposal titled,
 "Airport Communicator Software"*

Dr. Triant Flouris, Faculty Advisor
 Monica Singh and Matt McGinnis, team presenters

First Place – Runway Safety/Runway Incursions Challenge
*George Mason University, Fairfax, VA – proposal titled,
 "Runway Incursion Monitoring and Direct Alerting
 System (RIMDAS): A Proposed Solution to Preventing
 Runway Incursions"*

Dr. Raja Parasuraman, Faculty Advisor
 Carl E. Smith and Peter N. Squire, team presenters

First Place – Airport Environmental Interactions Challenge
*San Jose State University, San Jose, CA – proposal titled
 "Feasibility of Replacing Conventional Airport Lighting
 with Light Emitting Diodes"*

Dr. Triant Flouris, Faculty Advisor
 Michelle Sheffield and Caroline Quinanola,
 team presenters

1-3:45 p.m. **Metropolitan Washington Airports Authority Art in Architecture Tour**
 Bus loading begins at 1 p.m. and buses depart promptly at 1:15 p.m. from the "L" Street Entrance at the Washington Convention Center

1-4:30 p.m. **Capitol Hill Meetings**

WEDNESDAY, JUNE 13

**All sessions will be held at the Grand Hyatt Washington.*

8 a.m.-3 p.m. **Registration** Independence Foyer

8-9:30 a.m. **AAAE Executive Business Breakfast** Independence Ballroom
 (all delegates welcome)
Sponsored by CH2M HILL

9:30-10:30 a.m. **Concurrent Sessions**

- **Screening Checkpoint Technologies – How Will Technology Change the Customer Experience?** Constitution A

Moderator: Michael Stewart
*Director, External Affairs
 Jacksonville Airport Authority*

<p>Speakers: Adam Tsao <i>Deputy Assistant Administrator, Operational Process and Technology</i> U.S. Transportation Security Administration</p> <p>Patricia Krall <i>Vice President of Business Developments</i> L-3 Communications Security & Detection Systems</p> <p>Steve Pelham <i>Director, U.S. Sales</i> Reveal Imaging Technologies</p> <ul style="list-style-type: none"> • Aviation Ground Handling Issues – New Solutions to Resolve Old Problems <small>Constitution B/B Corridor</small> <p>Moderator: Bruce Carter, A.A.E. <i>Director of Aviation</i> Quad City International Airport</p> <p>Speakers: Gary A. Cyr <i>Director of Aviation</i> Springfield/Branson National Airport</p> <p>Eric J. Frankl, A.A.E. <i>Airports Director</i> Toledo-Lucas County Port Authority</p> <p>Stan Mackiewicz <i>Representative, Government and Industry Affairs</i> National Air Transportation Association</p> <ul style="list-style-type: none"> • Partnering with Local Chambers/ Economic Development Organizations/ Convention Bureaus to Attract Air Service – Capturing New Air Service by Creating a Unified Strategy <small>Constitution CDE</small> <p>Moderator: John Coon <i>Director of Operations</i> Lexington Blue-Grass Airport</p> <p>Speakers: Raymond Bishop <i>Airport Director</i> Jackson Hole Airport</p> <p>Kari Cooper Jackson Hole Air</p> <p>Robin Lee Monroe <i>Executive Vice President</i> InterVISTAS Consulting, Inc.</p> <p>Robert O'Brien, A.A.E. <i>Executive Director</i> Chicago/Rockland International Airport</p> <ul style="list-style-type: none"> • Wall Street View of the Airline Industry – Bankruptcies to Mergers: A New Airline Industry Emerges? <small>Farragut/Lafayette</small> <p>Moderator: Craig Williams, A.A.E. <i>Director, Finance and Administration</i> Fort Wayne-Allen County Airport Authority</p> <p>Speakers: D.J. Mehigan <i>Senior Vice President</i> Morgan Keegan & Co.</p> <p>Betsy Snyder <i>Airport Director</i> Standard & Poor's Rating's Services</p>	<p>10:30-11 a.m. Refreshment Break <small>Constitution Foyer</small> <i>Co-sponsored by AVIS Budget Group, Inc. and C & S Engineers, Inc.</i></p> <p>11 a.m-Noon Concurrent Sessions</p> <ul style="list-style-type: none"> • Emerging Baggage EDS Technologies – New Strategies to Ease Delays, Errors <small>Constitution A</small> <p>Moderator: Kim Dickie, C.M. <i>Assistant Deputy Airport Director</i> San Francisco International Airport</p> <p>Speakers: Theresa Coutu, C.M. <i>Government Relations Director</i> GE Security</p> <p>Mark Denari <i>Director, Aviation Security and Public Safety</i> San Diego County Regional Airport Authority</p> <p>Steve Wareham <i>Airport Director</i> Metropolitan Airports Commission</p> <ul style="list-style-type: none"> • Being Proactive and Prepared – GA Airport Security/Safety Update <small>Constitution B/B Corridor</small> <p>Moderator: Lisa Pyles, A.A.E. <i>Director</i> Addison Airport</p> <p>Speakers: Jeremy Howard <i>Global Accounts Director</i> Honeywell International</p> <p>Robert Ollislagers, A.A.E. <i>Executive Director</i> Centennial Airport</p> <p>Barbara Patzner, A.A.E. <i>Director</i> L.G. Hanscom Field</p> <ul style="list-style-type: none"> • Customer Service Challenges at Airports – Customers First Makes Airports Number One <small>Farragut/Lafayette</small> <p>Moderator: Charles Isdell, A.A.E. <i>Director of Aviation</i> Philadelphia International Airport</p> <p>Speakers: Kelly J. Fredericks, P.E., A.A.E. <i>Executive Director</i> Erie Municipal Airport Authority</p> <p>Elizabeth Hoium <i>Contracts and Projects Manager— Airport Operations</i> Metropolitan Airports Commission</p> <ul style="list-style-type: none"> • Airport Master Planning Trends – Drafting the Future <small>Franklin/McPherson</small> <p>Moderator: Jeff Bilyeu, A.A.E. <i>Airport Director</i> Lone Star Executive Airport</p> <p>Speakers: Michael J. Cheyne, A.A.E., PMP <i>Director, Aviation Planning</i> Seattle-Tacoma International Airport</p> <p>Steve Peters, AIA <i>Vice Presidents</i> Carter & Burgess, Inc.</p>
---	---

Conference Program

	<p>Kenneth E. Simmons, A.A.E. <i>Airport Operations Officer</i> Rapid City Regional Airport</p> <ul style="list-style-type: none"> • Panel of Airline Properties Reps – Deal or No Deal Constitution CDE 	
Moderator:	<p>Klaasje Nairne, C.A.E., C.M. <i>Airports Manager</i> San Luis Obispo County Regional Airport</p>	
Speakers:	<p>Laura Einspanier <i>Vice President, Corporate Real Estate</i> American Airlines, Inc.</p> <p>Robert Montgomery <i>Vice President of Properties</i> Southwest Airlines</p> <p>Robert Olislagers, A.A.E. <i>Executive Director</i> Centennial Airport</p> <p>Joseph E. Richardson <i>Airport Properties Manager</i> United Parcel Service</p>	
12:00-2:00 p.m.	<p>AAAE Awards Luncheon Independence Ballroom</p>	
Keynote Speaker:	<p>The Honorable Mary Peters <i>Secretary</i> U.S. Department of Transportation <i>Co-sponsored by Delaware North Companies Travel Hospitality Services, Honeywell International, International RAM Associates, PB Americas, Inc.</i></p>	
2:15-3:15 p.m.	<p>Concurrent Sessions</p> <ul style="list-style-type: none"> • Federal Inspection Services Update – FIS Changes Ease Lines, Passenger Delays Constitution A 	
Moderator:	<p>Karen W. Ellis <i>Customer Service Manager, Senior</i> Hartsfield-Jackson Atlanta International Airport</p>	
Speakers:	<p>Jose Santiago Chaves, ACE <i>Manager, Airport Security Division</i> Baltimore/Washington International Thurgood Marshall Airport</p> <p>Robert Jacksta <i>Executive Director of Travel Services</i> U.S. Customs and Border Protection</p> <p>Jason Terrieri <i>Airport Operations Supervisor</i> Hartsfield-Jackson Atlanta International Airport</p> <p>Steve Wareham <i>Airport Director</i> Metropolitan Airports Commission</p>	
	<ul style="list-style-type: none"> • Airport Community Outreach – Creating a Supportive Neighborhood Constitution B/B Corridor 	
Moderator:	<p>Sharon L. Sears <i>Marketing/Public Relations Manager</i> James M. Cox Dayton International Airport</p>	
Speakers:	<p>Ann B. Crook, C.M. <i>Airport Director</i> Klamath Falls Airport</p>	
		<p>Diane Summerhays <i>Director, Community Development</i> Seattle-Tacoma International Airport</p> <ul style="list-style-type: none"> • FAA Reauthorization – Debate Heats Up as Expiration of Current Authorization Bill Nears Constitution CDE
Moderator:	<p>Tory Richardson, A.A.E. <i>Executive Director of Airports</i> Fort Wayne-Allen County Airport Authority</p>	
Speaker:	<p>D. Kirk Shaffer <i>Associate Administrator for Airports</i> U.S. Federal Aviation Administration</p>	
		<ul style="list-style-type: none"> • Hot Legal Issues – If You Run an Airport, You Need a Lawyer Franklin/McPherson
Moderator:	<p>Edward P. Faberman <i>Partner</i> Wiley Rein LLP</p>	
Speakers:	<p>Thomas Devine <i>Partner</i> Kaplan, Kirsch & Rockwell LLP</p> <p>Michael R. McGinnis <i>Partner</i> Brownstein Hyatt & Farber, P.C.</p> <p>Thomas P. Nolan, A.A.E. <i>Assistant Director of Airports</i> Wichita Airport Authority</p>	
		<ul style="list-style-type: none"> • Airport Management Succession – Training Heirs to the Throne Farragut/Lafayette
Moderator:	<p>Marilyn Mora, C.M. <i>Deputy Executive Director</i> Reno-Tahoe International Airport</p>	
Speaker:	<p>Patrick Abeln, A.A.E. <i>Director of Aviation</i> El Paso International Airport</p>	
3:30-4:30 p.m.	<p>AAAE Board of Directors/ Policy Review Committee Meeting Wilson/Roosevelt</p>	
6-6:45 p.m.	<p>Chair's Reception Independence Foyer <i>Co-sponsored by Crawford Murphy & Tilly, Inc. and Honeywell International</i></p> <p><i>In conjunction with the MWAA Capital Club</i> <i>Sponsors: Alpha Corporation; Amman & Whitney; Giuliani Associates Architects, Inc.; Hogan & Hartson, LLP; Infrastructure Management Group; The Lane Construction Company, a joint venture of Parsons Corporation, DMJM Aviation, PB Americas, Inc., and Delon Hampton and Associates, Chartered; URS Corporation and Washington Airports Task Force</i></p>	
6:45-9:30 p.m.	<p>79th Annual AAAE Conference Final Banquet Independence Ballroom <i>Hosted by Metropolitan Washington Airports Authority</i></p>	
9:30-11 p.m.	<p>Dessert Reception Constitution Ballroom <i>Sponsored by Louis Armstrong New Orleans International Airport, host of the 80th Annual AAAE Conference and Exposition, June 8-11, 2008</i></p>	

For tour events, buses will pick up and drop off attendees at the 10th Street Entrance of the Grand Hyatt Washington.

SUNDAY, JUNE 10

- Noon-1:30 p.m. **Official Opening of Exhibit Hall and Luncheon** Hall A – Washington Convention Center
- 6:30-9:30 p.m. **Evening Event at Udvar-Hazy Center**
Sponsored by Metropolitan Washington Airports Authority (MWAA)
- Transportation and bus hospitality sponsored by Parsons Management Consultants, a joint venture of Parsons Corporation, DMJM Aviation, PB Americas, Inc., and Delon Hampton and Associates, Chartered*
- In conjunction with the MWAA Capital Club*
Sponsors: Alpha Corporation; Amman & Whitney; Giuliani Associates Architects, Inc.; Hogan & Hartson, LLP; Infrastructure Management Group; The Lane Construction Company, a joint venture of Parsons Corporation, DMJM Aviation, PB Americas, Inc., and Delon Hampton and Associates, Chartered; URS Corporation and Washington Airports Task Force
- Buses load at 5:45 p.m. in the Convention Center Parking Lot (across the street from the Grand Hyatt and the Renaissance D.C. hotels)

MONDAY, JUNE 11

- 9-10 a.m. **Breakfast and Orientation** Farragut/Lafayette Grand Hyatt Washington
- 9:30 a.m.-1:30 p.m. **Whirlwind Tour of Washington, D.C.**
Take a tour of the most requested sights in our nation's capital! Board our deluxe motor coach to see the very best monuments, memorials and world-famous landmarks in Washington, D.C., including the newest monument, the World War II Memorial. You'll stop at the Jefferson Memorial, Lincoln Memorial, Korean War Veterans' Memorial and the Vietnam Veterans' Memorial. You'll also see the Washington Monument, the White House, the U.S. Capitol and the U.S. Supreme Court. Be sure to bring your camera so you won't miss all those great photo opportunities, and your walking shoes for when we go to see the sites up close and personal!
- 5 – 7 p.m. **Corporate Appreciation Reception in the Exhibit Hall** Hall A – Washington Convention Center
Co-sponsored by Delaware North Companies Travel Hospitality Services, Jacobs Consultancy and Kimley-Horn and Associates

TUESDAY, JUNE 12

- 9:30 a.m. – 3:30 p.m. **A Visit to our Colonial Past with Shopping in Old Town Alexandria**
- Start the day at beautiful Mount Vernon, the beloved home of George and Martha Washington. We will travel back in time to the 18th century – to the life and times of The Father of our Country. The magnificent estate sits on a grassy, shaded slope overlooking the Potomac River. Pass through the newest additions to the estate: The Ford Orientation Center and Donald W. Reynolds Museum and Education Center. The 25 galleries and theaters that make up the new buildings house iconic artifacts and state-of-the-art exhibits that complement the historic area experience by illuminating fascinating chapters of Washington's life and much, much more. Enjoy lunch at the Mount Vernon Inn. The tour will end with a stop at the quaint seaport town of Old Towne Alexandria. Founded in 1749 and listed on the National Register of Historic Places, Old Towne is nationally recognized for its abundance of 18th- and 19th-century architecture, historic attractions, award-winning restaurants, unique shops and charming boutiques. Enjoy visiting the Torpedo Factory, a renovated World War I torpedo plant on the docks of the Potomac that is now a treasure trove of galleries and artists' studios.

WEDNESDAY, JUNE 13

- 6 – 6:45 p.m. **Chair's Reception** Independence Foyer
Co-sponsored by Crawford Murphy & Tilly, Inc. and Honeywell International
And in conjunction with the MWAA Capital Club
Sponsors: Alpha Corporation, Amman & Whitney, Giuliani Associates Architects, Inc., Hogan & Hartson, LLP, Infrastructure Management Group, The Lane Construction Company, a joint venture of Parsons Corporation, DMJM Aviation, PB Americas, Inc., and Delon Hampton and Associates, Chartered, URS Corporation, Washington Airports Task Force
- 6:45 – 9 p.m. **79th Annual AAAE Conference Final Banquet** Independence Ballroom
Hosted by Metropolitan Washington Airports Authority
- 9 – 11 p.m. **Dessert Reception** Constitution Ballroom
Sponsored by Louis Armstrong New Orleans International Airport, host of the 80th Annual AAAE Conference and Exposition, June 8-11, 2008

Washington Convention Center and Grand Hyatt Meeting Rooms

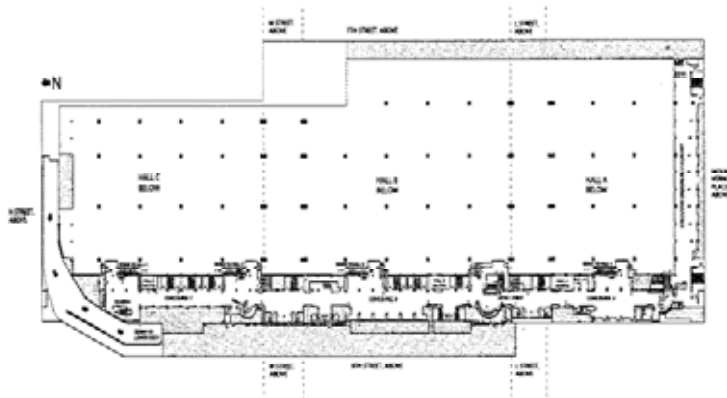

Concourses – A, B and C
Washington Convention Center

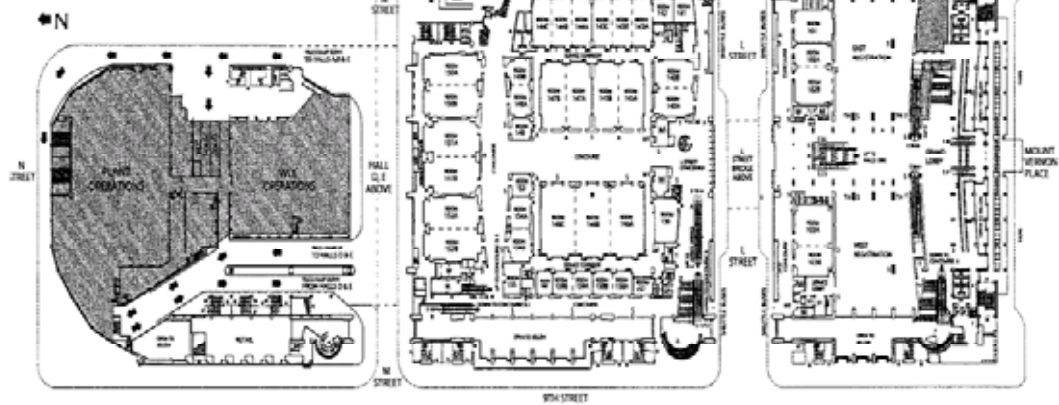

Street Level
Washington Convention Center

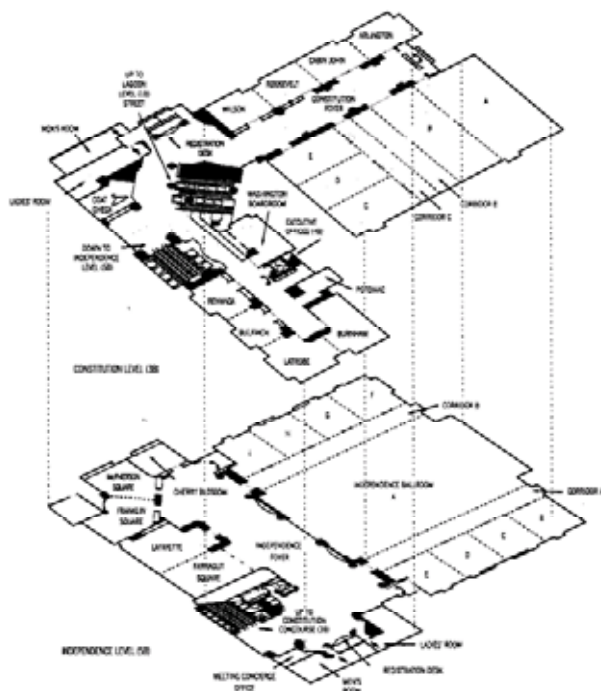

Grand Hyatt Washington

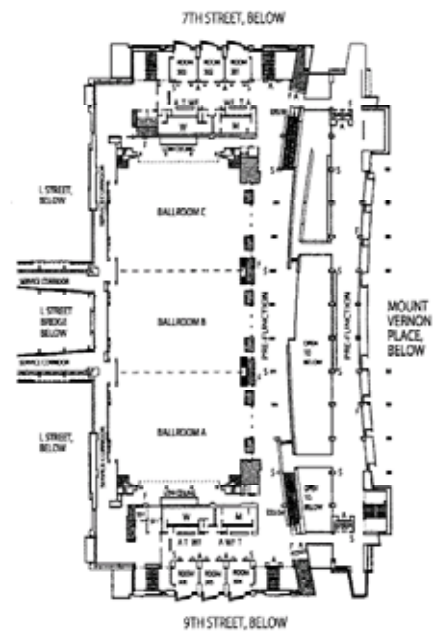

Level Three
Washington Convention Center

Washington Convention Center Exhibit Hall Floor Plan

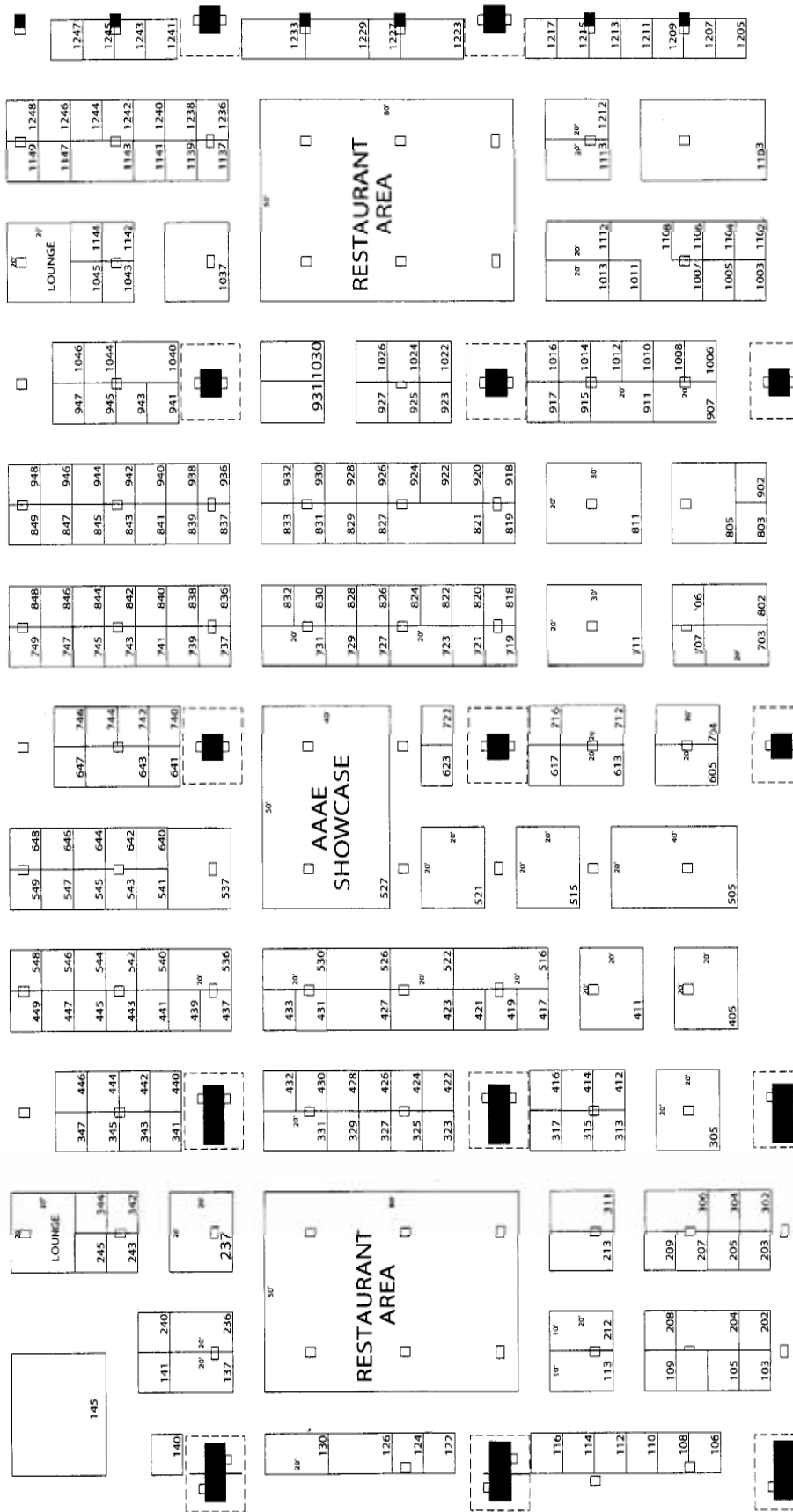

ENTRANCE

Participating Companies

as of 5.29 (alphabetical by organization name)

AAM.....114	DMJM Aviation/AECOM.....536	Jane's Information Group.....430	Rosenbauer.....1044
ACE Parking Management.....1142	Door Control Systems.....1003	Jervis B. Webb Company.....417	Rural/Metro Fire Department.....329
ACI-NA.....124	DoorKing, Inc.....731	JetBridge Technology, Inc.....1205	Rytec Corporation.....405
ADT Security Services.....212	Earth Tech, Inc.....412	JR Group.....110	Safegate Airport Systems, Inc.....236
Aeroterm US, Inc.....343	The Electric Guard Dog.....103	Kimley-Horn and Associates, Inc.....1112	Sagem Morpho Inc.....923
Aigis Blast Protection Inc.....1141	Elgin Sweeper Company.....145	KJM & Associates.....1016	Samsung Electronics America, Inc.....1233
Aircraft Rescue + Firefighting Working Group, Inc.....824	Embry Riddle Aeronautical University - College of Business.....742	Klondike Kidstuff, Inc.....140	Selex Sistemi Integrati.....345
Airport 20/20.....818	Engineered Arresting Systems Corp. (ESCO - ZODIAC).....704	KONE Inc.....423	Sensis Corporation.....342
Airport Business Magazine.....327	Enterprise Rent A Car.....839	L-3 Communications.....1057	Seroo Inc.....1011
Airport Business Solutions.....819	E-ONE.....1103	Language Line Services.....1209	Siemens.....305
Airport Consultants Council.....907	EQ Airport Services.....644	Linc Facility Services.....208	Signature Flight Support.....707
Airport Magazine.....729	The Escalator Cleaning Co.....830	Lochard Corporation.....137	SIT BACK + RELAX LLC.....537
Airport Seating Alliance.....515	Era.....1212	Logan Teleflex, Inc.....1139	SITA.....722
Airports International Magazine.....840	ESA Airports.....926	Logical Decisions, Inc.....106	Smarte Carte, Inc.....716
Air-Transport IT Services, Inc. (AirIT).....1223	FAA - Technology Development.....442	Louis Armstrong New Orleans International Airport.....304	The Solution Design Group.....928
AirValet, Inc.....1043	FAA Satellite Navigation (SatNav).....945	The Louis Berger Group, Inc.....932	South Central Chapter AAAE.....940
All Weather, Inc.....1007	Federal APD, Inc.....126	Magal Sensata, Inc.....821	Southwest Microwave, Inc.....803
Alpine Systems.....1213	Five Star Airport Alliance.....126	Magnetic Automation Corp.....315	Standard Parking.....1026
American Science & Engineering, Inc.....802	FKI Logistics.....1010	Matrix Systems.....426	SUBWAY®.....422
Ammann & Whitney.....1236	Flex-O-Lite.....204	Mead & Hunt.....323	SuperShuttle International, Inc.....433
Ampoo System Parking.....203	Flight Safety Foundation.....1243	Megadata/Passair.....419	Tandus US Inc.....643
Architectural Alliance.....437	Flightview/RLM Software, Inc.....838	Metropolitan Washington Airports Authority.....931	Technology Planning Incorporated.....1247
ARCONAS.....311	FMC Technologies, Inc. - Jerway.....727	The Milestones Project.....1229	Tensor International Corporation.....344
ARINC, Inc.....805	G&S Mechanical USA Inc.....122	Milliken Carpet.....237	Thales ATM, Inc.....833
Armbrust Aviation Group, Inc.....1245	GCR + Associates, Inc.....743	The MITRE Corporation.....938	ThyssenKrupp Airport Systems, Inc.....439
Arora Engineers, Inc.....347	GE Security.....1147	MSE Branded Foods.....902	Tilt-A-Way/Ideal Manufacturing, Inc.....1013
Atrax Group Limited.....924	Genetec, Inc.....915	Nabeo Inc.....1102	TransCore.....703
Austin Commercial, L.P.....745	GeoEye (formerly Space Imaging).....925	Neenah Foundry Company.....936	Trans-Lux Corporation.....130
Aviation Capital Management.....209	Giuliani Associates Architects, Inc.....427	New Bedford Panoramex.....113	Transoft Solutions.....927
Axima Airport Services.....240	Glidepath LLC.....331	NGVAmerica.....1241	Transpo Industries, Inc.....737
Axyis Technologies - IR Systems.....443	Global Ground Support, LLC.....1106	Northeast Chapter AAAE.....543	Transtech Airport Solutions.....1024
BAE Systems.....943	HID Corporation.....829	Northwest Chapter AAAE.....744	Traveler's Aid International.....642
BASF Admixtures.....721	Honeywell International.....811	OAG Worldwide.....723	Turner Aviation.....341
Bella Bagno, Inc.....432	Hudson Group.....505	Odell Associates, Inc.....647	TYMCO.....421
Besam Entrance Solutions.....207	Hunt Construction Group Inc.....917	Off the Wall Products LLC.....444	U.S. Cost, Inc.....540
Blast Deflectors, Inc.....820	Hurley Corporation.....1006	Old World Industries, Inc.....116	University of North Dakota.....842
Bombardier Transportation.....837	HySecurity.....424	Oshkosh Truck Corporation.....613	UNICCO Service Company.....741
Bradford Airport Logistics.....109	I.D. Systems, Inc.....1211	Parking Locator.....317	Unisys Corporation.....1046
Brill Hygienic Products, Inc.....623	IER.....746	Parsons Brinckerhoff.....1030	URS Corporation.....521
Burns & McDonnell.....526	IMDC, Inc.....202	Parsons Transportation Group.....306	Vanderlande Industries, Inc.....530
The Burns Group.....920	INET Airport Systems.....1005	Passenger Terminal Expo.....822	Vector Airport Revenue Solutions.....205
BWI Airport.....441	Infax, Inc.....541	Penta Corporation.....112	Vehicle Protection Structures.....1215
CDM.....930	Inland Technologies.....141	PGAL.....213	Vigilant Solutions LLC.....1137
Central Parking System.....922	Innovative Electronic Designs, Inc.....712	PlantCML.....826	W.D. Schock Company, Inc.....836
CLEAR Verified Identity Pass, Inc.....411	IntellEnergy.....1240	PLAYTIME, LLC.....641	Walker Parking Consultants.....832
Clough Harbour + Associates.....640	Intergraph Corporation.....740	Prime Engineering, Inc.....431	Wandering Wi-Fi.....414
Cobus Industries, LP.....806	International Air Rail Organization.....416	Professional Airways Systems Specialists, AFL-CIO.....1227	Wyle Laboratories.....827
Com-Net Software.....516	International Display Systems, Inc.....1040	Prospect Airport Services, Inc.....107	The Yockock Wall Company, Inc.....446
CPI Daylighting, Inc.....302	International RAM Associates - TSG.....1113	Pro-Tec Fire Services, Ltd.....1014	
Crash Rescue Equipment Service, Inc.....941	Interroll Automation LLC.....313	PRT Consulting, Inc.....1012	
Cross March Technologies, Inc.....428	InterSystems USA, Inc.....911	QinetiQ.....440	
Crowe Chizek and Company LLC 1238	Intralox LLC.....1108	Radiant Aviation Services, Inc.....105	
The D.S. Brown Company.....918	ITW GSE Group - Hobart - Trilectron - J & B Aviation.....1008	Rampart Hydro Services.....831	
Daktronics, Inc.....522		Reveal Imaging Technologies.....711	
Deschamps Mats Systems, Inc.....841		Reynolds, Smith and Hills, Inc.....605	
DeTeklon Security Systems, Inc.....739		Rice Lake Weighing Systems.....828	
Dewbridge Airport Systems.....719		Robinson Aviation (RVA), Inc.....1217	
DME Corporation.....325			

Participating Companies

as of 5.29 (listed by numerical booth order)

The Electric Guard Dog.....103	KONE Inc.....423	GCR + Associates, Inc.....743	Trilectron - J & B Aviation.....1008
Radiant Aviation Services, Inc.....105	HySecurity.....424	Northwest Chapter AAAE.....744	FKI Logistics.....1010
Logical Decisions, Inc.....106	Matrix Systems.....426	Austin Commercial, L.P.....745	Serco Inc.....1011
Prospect Airport Services, Inc.....107	Giuliani Associates	IER.....746	PRT Consulting, Inc.....1012
ObjectVideo.....108	Architects, Inc.....427	American Science &	Tilt-A-Way/Ideal
Bradford Airport Logistics.....109	Cross Match Technologies, Inc.....428	Engineering, Inc.....802	-Manufacturing, Inc.....1013
JR Group.....110	Jane's Information Group.....430	Southwest Microwave, Inc.....803	Pro-Tec Fire Services, Ltd.....1014
Petra Corporation.....112	Prime Engineering, Inc.....431	ARINC, Inc.....805	KJM & Associates.....1016
New Bedford Panoramex.....113	Bella Dagno, Inc.....432	Cobus Industries, LP.....806	Transtech Airport Solutions.....1024
AAM.....114	SuperShuttle International, Inc.....433	Honeywell International.....811	Standard Packing.....1026
Old World Industries, Inc.....116	Architectural Alliance.....437	Airport 20/20.....818	Parsons Brinckerhoff.....1030
G&S Mechanical USA Inc.....122	ThyssenKrupp Airport	Airport Business Solutions.....819	L-3 Communications.....1037
ACI-NA.....124	Systems, Inc.....439	Blast Deflectors, Inc.....820	International Display
Five Star Airport Alliance.....126	QinetiQ.....440	Magal Sensear, Inc.....821	Systems, Inc.....1040
Trans-Lux Corporation.....130	BWT Airport.....441	Passenger Terminal Expo.....822	AirValet, Inc.....1043
Lochard Corporation.....137	FAA - Technology Development.....442	Aircraft Rescue + Firefighting	Rosenbauer.....1044
Klondike Kidstruff, Inc.....140	Asys Technologies - IR Systems.....443	Working Group, Inc.....824	Unisys Corporation.....1046
Inland Technologies.....141	Off the Wall Products LLC.....444	PlantCML.....826	Nabco Inc.....1102
Elgin Sweeper Company.....145	The Yodock Wall Company, Inc.....446	Wyle Laboratories.....827	E-ONE.....1103
IMDC, Inc.....202	Hudson Group.....505	Rice Lake Weighing Systems.....828	Global Ground Support, LLC.....1106
Ampco System Parking.....203	Airport Seating Alliance.....515	HID Corporation.....829	Intralox LLC.....1108
Flex-O-Lite.....204	Com-Net Software.....516	The Escalator Cleaning Co.....830	Kimley-Horn and
Vector Airport Revenue Solutions.....205	URS Corporation.....521	Rampart Hydro Services.....831	Associates, Inc.....1112
Besam Entrance Solutions.....207	Daktronics, Inc.....522	Walker Parking Consultants.....832	International RAM
Line Facility Services.....208	Burns & McDonnell.....526	Thales ATM, Inc.....833	Associates - TSG.....1113
Aviation Capital Management.....209	Vanderlande Industries, Inc.....530	W.D. Schock Company, Inc.....836	Vigilant Solutions LLC.....1137
ADT Security Services.....212	DMJM Aviation/AECOM.....536	Bombardier Transportation.....837	Logan Teleflex, Inc.....1139
PGAI.....213	SIT BACK + RELAX LLC.....537	Flightview/RLM Software, Inc.....838	Aigis Blast Protection Inc.....1141
Safegate Airport Systems, Inc.....236	U.S. Cost, Inc.....540	Enterprise Rent A Car.....839	ACE Parking Management.....1142
Milliken Carpet.....237	Infax, Inc.....541	Airports International Magazine.....840	GE Security.....1147
Axima Airport Services.....240	O.R. Colan Associates.....542	Deschamps Mats Systems, Inc.....841	JetBridge Technology, Inc.....1205
Federal APD, Inc.....243	Northeast Chapter AAAE.....543	University of North Dakota.....842	Language Line Services.....1209
CPI Daylighting, Inc.....302	Reynolds, Smith and Hills, Inc.....605	MSE Branded Foods.....902	L.D. Systems, Inc.....1211
Louis Armstrong New Orleans	Oshkosh Truck Corporation.....613	Airport Consultants Council.....907	Era.....1212
International Airport.....304	Brill Hygienic Products, Inc.....623	InterSystems USA, Inc.....911	Alpine Systems.....1213
Siemens.....305	Clough Harbour + Associates.....640	Genetec, Inc.....915	Vehicle Protection Structures.....1215
Parsons Transportation Group.....306	PLAYTIME, LLC.....641	Hunt Construction Group Inc.....917	Robinson Aviation (RVA), Inc.....1217
ARCONAS.....311	Traveler's Aid International.....642	The D.S. Brown Company.....918	Air-Transport IT
Interroll Automation LLC.....313	Tandus US Inc.....643	The Burns Group.....920	Services, Inc. (AirIT).....1223
Magnetic Automation Corp.....315	EQ Airport Services.....644	Central Parking System.....922	Professional Airways Systems
Parking Locator.....317	Odell Associates, Inc.....647	Sagem Morpho Inc.....923	Specialists, AFL-CIO.....1227
Mead & Hunt.....323	TransCore.....703	Attrax Group Limited.....924	The Milestones Project.....1229
DME Corporation.....325	Engineered Arresting Systems	GeoEye (formerly Space Imaging).....925	Samsung Electronics
Airport Business Magazine.....327	Corp. (ESCO - ZODIAC).....704	ESA Airports.....926	America, Inc.....1233
Rural/Metro Fire Department.....329	Signature Flight Support.....707	Transoft Solutions.....927	Ammann & Whitney.....1236
Glidepath LLC.....331	Reveal Imaging Technologies.....711	The Solution Design Group.....928	Crowe Chizek and
Turner Aviation.....341	Innovative Electronic	CDM.....930	Company LLC.....1238
Sensis Corporation.....342	Designs, Inc.....712	Metropolitan Washington	IntellEnergy.....1240
Aerostorm US, Inc.....343	Smarte Carte, Inc.....716	Airports Authority.....931	NGVAmerica.....1241
Tensar International Corporation.....344	Dewbridge Airport Systems.....719	The Louis Berger Group, Inc.....932	Flight Safety Foundation.....1243
Selex Sistemi Integrati.....345	BASF Admixtures.....721	Necmah Foundry Company.....936	Arbreat Aviation Group, Inc.....1245
Arora Engineers, Inc.....347	SITA.....722	The MITRE Corporation.....938	Technology Planning
Rytec Corporation.....405	OAG Worldwide.....723	South Central Chapter AAAE.....940	Incorporated.....1247
CLEAR Verified	FMC Technologies, Inc. - Jerway.....727	Crash Rescue Equipment	
Identity Pass, Inc.....411	Airport Magazine.....729	Service, Inc.....941	
Earth Tech, Inc.....412	DoorKing, Inc.....731	BAE Systems.....943	
Wandering Wi-Fi.....414	Transpo Industries, Inc.....737	FAA Satellite Navigation	
International Air Rail	DeTekon Security Systems, Inc.....739	(SatNav).....945	
Organisation.....416	Intergraph Corporation.....740	Door Control Systems.....1003	
Jervis B. Webb Company.....417	UNICCO Service Company.....741	INET Airport Systems.....1005	
Megadata/Passur.....419	Embey Riddle Aeronautical	Hurley Corporation.....1006	
TYMCO.....421	University - College	All Weather, Inc.....1007	
SUBWAY*.....422	of Business.....742	ITW GSE Group - Hobart -	

Where to Find ...

Advertising 317, 430	Associations 124, 416, 527, 543, 744, 907, 940, 1227, 1241, 1243	Consultants 542, 819, 827, 832, 836, 926, 930, 938
Air Traffic Control Equipment 113, 342, 1212	Baggage Handling Equipment 122, 126, 240, 305, 313, 331, 417, 530, 1010, 1102, 1108, 1139	Disaster Planning and Response 1102
Air Traffic Control Services 1011, 1217	Car Rentals 839	Display Systems 130, 522, 1223, 1233
Aircraft Information and Tracking 205, 419, 838	Cargo Equipment 305	Doors & Door Control 207, 305, 315, 405, 731, 1003
Aircraft Rescue & Firefighting Equipment/Services 329, 613, 824, 841, 941, 1014, 1044, 1103	Concessions, Food 422, 505, 902	Educational Institutions 742, 842, 1229
Airfield/Apron Buses 806	Concessions, Gifts 505	Engineering Services 113, 202, 536, 920, 930, 1112
Airfield Specialty Surfaces 943	Concessions, Newsstands 505	Environmental Compliance 1241
Airports 304, 441, 931	Concessions, Specialty 505, 537, 641, 1043	Environmental Services 141, 536, 644, 926, 930
Architects/Engineers/Planners 213, 323, 42, 427, 431, 437, 521, 526, 536, 605, 640, 647, 932, 1012, 1030, 1112, 1236	Construction 423	Facility Maintenance Equipment and Services 240, 305, 830
	Construction Management 306, 521, 536, 540, 745, 917	Facility Management 208, 305, 741
		Fencing 315, 737, 739, 820
		Financial/Business Management 419, 743, 1223
		Fire Detection & Control Systems 305, 811
		Fixed Base Operators 707
		Flight & Baggage Info. Display Systems 516, 541, 712, 818, 911, 1040, 1213
		Floor Covering 237, 643
		Floor Maintenance 741
		Furniture, Terminal 311, 515
		Ground Support Equipment 105, 145, 1005, 1008, 1106
		Ground Support Maintenance 145

Let a walk through the exhibit hall provide the perfect escape... Fill out the exhibit hall survey form included in your registration bag and you will be eligible to win a two-night stay for two at the beautiful Loews Ventana Canyon Resort, Tucson, Arizona. Deposit your completed survey at the AAAE Showcase. The drawing will be held during the AAAE Awards Luncheon on Wednesday, June 13, in the Independence Ballroom, Grand Hyatt Washington. You do not need to be present to win, however only fully completed forms will be accepted.

Ground Transportation 433, 703, 1241	Pavement, Concrete and Asphalt 114, 344, 721, 737, 918, 936	Security, Surveillance Systems 108, 212, 305, 315, 440, 443, 811, 821, 915, 1024, 1113
Internet Services 419	Power/Electrical Services 305	Signs, Airfield 236, 305
IT Services 305, 805, 928	Program Management 209, 521, 536, 540, 1016	Snow and Ice Control 116
Land Acquisition 542, 836	Publications 327, 729, 840	Software, Information Systems 107, 305, 722, 723, 740, 828, 1211, 1223
Lighting, Airfield 113, 204, 236, 305, 325, 444, 811	Registered Traveler 411	Software, Management Systems 305, 818, 927
Lighting, Terminal 305	Restroom Products and Supplies 432, 623	Sweepers 145, 421
Lighting, Transient Area 305	Rubber Deposit Removal 831	Systems Integration 113, 305, 536, 811, 826, 1113, 1223
Lockers 716	Safety Equipment 444, 446, 704, 1141, 1211	Telephone Equipment 305, 826
Luggage Carts 716	Security, Screening Services 305, 536, 1037, 1113	Terminal Equipment 236, 315, 746, 828, 924
Maintenance, Airfield 444, 831	Security, Access Control 103, 106, 109, 212, 305, 315, 424, 426, 444, 703, 731, 803, 805, 811, 829, 923, 1013, 1113, 1211	Weather Services 1007
Maintenance, Building 741, 1006	Security, Biometrics/Fingerprinting 305, 315, 428, 444, 811, 923, 1113	Windows and Window Treatments 302
Marketing Services 317	Security, Screening Equipment 305, 315, 711, 802, 1102, 1113, 1147	Wireless Communications/Technology 107, 305, 414, 1211, 703
Navigational Aids 345, 833, 925		
Noise Abatement 419, 836, 926		
Paging/Announcement Systems 112, 516, 712		
Parking Equipment 243, 305, 315, 317, 703		
Parking Revenue Control 243, 315		
Parking Services 203, 317, 703, 922, 1026		
Passenger Boarding Bridges 439, 719, 727		
Passenger Services 107, 140, 317, 617, 641, 642, 716, 837, 1209		

The Show Floor Give-A-Way Tour!

Win great prizes by just taking a walk through the exhibit hall. Drop your business cards in the fishbowls that have the 2007 annual conference logo displayed on them and you will be eligible to win great prizes donated by the AAEE exhibitors. A list of sponsoring companies, the prizes, and the date and time of each of the drawings will be on a flyer in all registration bag as well as on signs in the exhibit hall.

AAAE would like to thank the following companies for their contributions to this conference:

DIAMOND SPONSORS

Metropolitan Washington Airports Authority

Parsons Management Consultants, a joint venture of Parsons Corporation, DMJM Aviation, PB Americas, Inc., and Delon Hampton and Associates, Chartered

Signature Flight Support

PLATINUM SPONSORS

HMSHost

Siemens

Delaware North Companies Travel Hospitality Services

Reynolds, Smith & Hills, Inc.

Booz Allen Hamilton, Inc.

Reveal Imaging Technologies, Inc.

Carter & Burgess, Inc.

Honeywell International

Hudson Group

Memphis-Shelby County Airport Authority

URS Corporation

AREAS USA

CH2M HILL

Ricondo & Associates, Inc.

Berkley Aviation, LLC

CLEAR | Verified Identity Pass, Inc.

DMJM Aviation/AECOM

Jacobs Consultancy

PB Americas, Inc.

Skanska USA Building Inc.

Midwest Air Traffic Control Services, Inc.

Robinson Aviation (RVA), Inc.

Sercio, Inc.

ADS-B Team (ERA, Harris Corporation, IBM, Lockheed Martin, Inc., Parsons, Sensis Corporation)

GOLD WINGS SPONSORS

ARINC, Inc.

AvPorts, Inc.

Hunt Construction Group Inc.

The Paradies Shops, Inc.

Crawford, Murphy & Tilly, Inc.

Creative Host Services, Inc. DBA

ERA

Faber, Coe & Gregg, Inc.

FirstLine Transportation Security

Gresham, Smith & Partners

HNTB Corporation

Jacobs Engineering

Kimley-Horn and Associates, Inc.

Leo A. Daly Co.

The LPA Group Inc.

Phoenix Sky Harbor International Airport

Reno-Tahoe Airport Authority

International RAM Associates

SILVER WINGS SPONSORS

Heery International, Inc.

Hanson Professional Services Inc.

Hatch Mott MacDonald

Westfield Concession Management

will provide water for conference attendees upon arrival at both Ronald Reagan Washington National Airport and Washington Dulles Airport beginning Friday, June 8, and continuing until Monday, June 11. Beginning Wednesday, June 13, departing attendees will receive complimentary luggage tags. Look for the Welcome Kiosk at both airports!

HDS Retail North America
 Airport Magazine
 Avis Budget Group, Inc.
 C & S Engineers, Inc.
 Kennedy/Jenks Consultants
 Mead & Hunt, Inc.
 DM Airport Developers, Operator of Morristown
 Municipal Airport

AIRPORT ANGELS

SuperShuttle International, Inc.
 Woodward & Associates
 PBS&J
 TransCore
 Airport Business Solutions
 Aviation Facilities Company, Inc.
 Bombardier Transportation
 Boyden Global Executive Search
 Coffman Associates, Inc.
 Delta Airport Consultants, Inc.
 Engineered Arresting Systems Corp. (ESCO)
 Great Lakes Chapter AAAE
 The Hertz Corporation
 Hoyle, Tanner & Associates, Inc.
 Interspace Airport Advertising
 L-3 Communications Security & Detection Systems
 Landrum & Brown, Inc.
 Linc Facility Services
 Northeast Chapter AAAE
 Northwest Chapter AAAE
 O.R. Colan Associates
 Patton Boggs LLP
 PLANT/CML
 South Central Chapter AAAE
 Southeast Chapter AAAE
 Southwest Chapter AAAE
 Stantec Consulting, Inc.
 TBI Airport Management

Technical & Professional Services, Inc.
 Transtech Airport Solutions Inc.
 Wetland Studies & Solutions, Inc.
 Odell Associates, Inc.

CAPITAL CLUB SPONSORS

Alpha Corporation
 Ammann & Whitney
 Giuliani Associates Architects
 Hogan & Hartson LLP
 Infrastructure Management Group, Inc.
 The Lane Construction Corporation
 Parsons Management Consultants, a joint venture of
 Parsons Corporation, DMJM Aviation, PB Americas, Inc. and
 Delon Hampton and Associates, Chartered
 URS Corporation
 Washington Airports Task Force

AAAE would like to thank the following
 sponsors who made very important
 conference features possible:

Badge/Lead Retrieval: Reveal Imaging Technologies, Inc.
Buyers Guide: Signature Flight Support
Complimentary Internet Access in the Exhibit Hall: Clear I Verified
 Identity Pass, Inc.
Conference Daily Dispatch: The LPA Group, Transcore, PBS&J,
 Honeywell International and Jacobs Consultancy
Conference Program: ADS-B team including: ERA, Harris &
 Associates, IBM Corporation, Lockheed Martin, Parsons Inc.,
 Sensis Corporation
Exhibit Hall Aisle Sponsor: Mead and Hunt, Reynolds, Smith & Hills,
 Inc. and Airport Magazine
Exhibit Hall Lounge Area Sponsor: ARINC, Honeywell International
Hotel Key Card: HMSHost
Jumbo-Tron: Hunt Construction Group and AvPorts
Lanyards: Reynolds, Smith & Hills, Inc.
Pressroom: ARINC, Inc.
Registration Area Sign-In Kiosk: Carter & Burgess, Inc.
Sunday Night Event Transportation and Hospitality: Parsons Management
 Consultants, a joint venture of Parsons Corporation, DMJM Aviation,
 PB Americas, Inc., and Delon Hampton and Associates, Chartered
Totebags: Siemens

Sponsor Directory

For many years, AAEA has relied on its corporate members and friends for financial support. At the same time, we strive to make such corporate support of value to each company by providing recognition and public thanks. As you will see throughout the conference program, different companies are recognized for their contributions. Please acknowledge the support that these companies provide and take every opportunity to make them aware of your appreciation. Without this support from our corporate members and friends, AAEA would not be what it is today.

Airport Business Solutions
Mr. Michael Hodges
President & CEO
10014 N Dale Mabry Hwy., Ste. 101
Tampa, FL 33618
Phone: (813)269-2525
Fax: (813)269-8022
mhodges@airportbusiness.net

Airport Magazine
Mr. Sean Broderick
Editor
601 Madison St., #400
Alexandria, VA 22314
Phone: (703)824-0504
Fax: (703)820-1395
Sean.broderick@aaae.org

Alpha Corporation
Mr. Philios Angelides, P.E.
Sr. Vice President
2131 Ridgeway Circle, Ste. 200
Dulles, VA 20166
Phone: (703)450-0800 X 122
Fax: (703)450-0043
pangelides@alphacorporation.com

Ammann & Whitney
Mr. Bal K. Cherwoo, P.E.
Senior Vice President
2445 M St., NW
Washington, D.C. 20037
Phone: (202)331-1029
Fax: (202)331-7490
bcherwoo@ammann-whitney.com

AREAS USA
Mr. Xavier Rabell
CEO
5301 Blue Lagoon Dr. Ste. 690
Miami, FL 33126
Phone: (305)267-8510
Fax: (305)675-8488
xrabell@areasusa.com

ARINC, Inc.
Ms. Kimberly Pircio
Marketing Assistant
137 Mitchells Chance Rd.
Edgewater, MD 21037
Phone: (410)956-3050
Fax: (410)956-5465
kpircio@arinc.com

Aviation Facilities Company, Inc.
Mr. Francis X. Chambers Jr.
President & CEO
7600 Colshire Dr., Ste. 240
McLean, VA 22102
Phone: (703)288-8580
Fax: (703)902-2901
fchambers@afcoinc.com

Avis Budget Group, Inc.
Mr. Robert F. Bouts
Senior Vice President
6 Sylvan Way, 3rd Floor
Parappany, NJ 07054
Phone: (973)496-3438
Fax: (973)496-3441
robert.bouts@avisbudget.com

AvPORTS
Mr. John Harden
Vice President
90 Moonachie Ave
Teterboro, NJ 07608-1003
Phone: (201)288-5218
Fax: (201) 288-5143
jharden@avports.com

Berkley Aviation, LLC
Mr. Jason R. Niemela
President
3780 State St. Ste. C
Santa Barbara, CA 93105
Phone: (805)898-7641
Fax: (805)898-7690
jniemela@berkleyaviation.com

Bombardier Transportation
Mr. Edward A. Gordon
Vice President, Marketing-APM
1501 Lebanon Church Rd.
Pittsburgh, PA 15236
Phone: (412)655-5336
Fax: (412)650-6486
ed.a.gordon@us.transport.bombardier.com

Booz Allen Hamilton, Inc.
Dr. W. Evert Meyer
Principal
8283 Greensboro Dr.
McLean, VA 22102
Phone: (415)281-4753
Fax: (415)627-6296
meyer_evert@bah.com

Boyden Global Executive Search
Mr. Timothy C. McNamara
Managing Director
1200 G St., NW, Ste. 800
Washington, D.C. 20005-6705
Phone: (877)-2-BOYDEN
Fax: (202)536-5169
tmcnamara@boyden.com

C & S Engineers, Inc.
Mr. Michael D. Hotaling
Vice President
2020 Camino Del Rio North, Ste. 200
San Diego, CA 92108
Phone: (619)296-9373
Fax: (619)296-5978
mhotaling@csos.com

Carter & Burgess, Inc.
Mr. Loy E. Warren III, P.E.
Vice President and National Aviation Manager
777 Main St.
Fort Worth, TX 76101
Phone: (817)735-6144
Fax: (303)735-6159
loy.warren@c-b.com

CH2M HILL
Mr. James A. Moorcroft
Vice President
200 Corporate Center Dr., Ste. 150
Moon Township, PA 15108
Phone: (412)604-4073
Fax: (412)604-4525
james.moorcroft@ch2m.com

CLEAR | Verified Identity Pass, Inc.
Ms. Molly Greenberg
Marketing Manager
1270 Avenue of the Americas, Ste. 508
New York, NY 10020
Phone: (212) 332-6311
Fax: (212) 332-6302
mgreenberg@verifiedidpass.com

Coffman Associates, Inc.
Ms. Jeanette V. Coffman
Chief Executive Officer
237 N.W. Blue Pkwy, Ste. 100
Lee's Summit, MO 64063-1869
Phone: (816)524-3500
Fax: (816)524-2575
jeanette@coffmanassociates.com

Crawford, Murphy & Tilly, Inc.
Mr. Michael J. Doerfler
Senior Vice President
2750 W. Washington
Springfield, IL 62702
Phone: (217)787-8050
Fax: (217)787-4183
mdoerfler@cmtenet.com

Creative Host Services, Inc. DBA
Mr. Roderick I. McOwan
VT, Business Development
5 River Rd., Ste. 27
Wilton, CT 06897
Phone: (203)563-9500
Fax: (704)295-5983
roddy.mcowan@compass-usa.com

Delaware North Companies
Travel Hospitality Services
Mr. Nicholas Biello
President
40 Fountain Plaza
Buffalo, NY 14202-2885
Phone: (716)858-5122
Fax: (716)858-5245
nbiello@dninc.com

Delta Airport Consultants, Inc.
Mr. Charles D. Lamb, C.M., P.E.
President
9711 Farrar Ct., Ste. 100
Richmond, VA 23236
Phone: (804)275-8301
Fax: (804)275-8371
clamb@deltairport.com

DM Airport Developers Operators
of Morristown Municipal Airport
Mr. William G. Barkhauer, A.A.E.
Airport Director
8 Airport Rd.
Morristown, NJ 07960-4624
Phone: (973)538-6400, Ext. 111
Fax: (973)538-6947
billb@mmuair.com

DMJM Aviation/AECOM
Mr. John O'Connor
CEO
2202 N. West Shore Blvd., Ste. 455
Tampa, FL 33607-5747
Phone: (813)675-2115
Fax: (813)675-2150
john.oconnor@dmjaviation.com

Engineered Arresting Systems Corp.
Mr. Kevin Qian, C.M.
Regional Director, EMAS
2239 High Hill Rd.
Logan Township, NJ 08085
Phone: (856)241-8620, Ext. 452
Fax: (856)241-8621
kqian@esco.aodiac.com

ERA
Mr. Russell Hulstrom
V.P. Sales
5252 Cherokee Ave., Ste. 400
Alexandria, VA 22312
Phone: (703)914-1430
Fax: (703)914-1454
rhulstrom@erabeyondradar.com

Faber, Coe & Gregg
Mr. Charles Finkelstein
President
550 Meadowlands Pkwy
Secaucus, NJ 07094-1815
Phone: (201)330-1515
Fax: (201) 330-9560

FirstLine Transportation Security
Mr. Gary Smedile
V.P. of Business Development
4417 NW Briarcliff
Kansas City, MO 64116
Phone: (816)564-1863
Fax: (615)301-1273
gsmedile@firstlines.com

Giuliani Associates Architects, Inc.
Mr. Mark Giuliani
Managing Principal
1000 Connecticut Ave.
Washington, D.C. 20036
Phone: (202)828-2502
Fax: (202)296-7471
mlg@gia.com

Great Lakes Chapter AAAE
Mr. Kenneth R. Newstrom
Executive Director
P.O. Box 541209
Lake Worth, FL 33454-1209
Phone: (561)439-6160
Fax: (561)439-6161
glc-aae-ofc@aet.net

Gresham, Smith & Partners
Mr. Daniel A. Viscardi, P.E.
Executive Vice President
511 Union St., Ste. 1400
Nashville, TN 37219
Phone: (615)770-8100
Fax: (615)770-8557
dan_viscardi@gsppnet.com

Hanson Professional Services Inc.
Mr. Todd Knuckey
Principal, Aviation Services
1525 S. Sixth St.
Springfield, IL 62703
Phone: (217)788-2450
Fax: (217)788-2503
tknuckey@hanson-inc.com

Harris Corporation
Ms. Carol Gabica
Manager, Business Development
P.O. Box 37
Melbourne, FL 32902
Phone: (321)309-7280
Fax: (321)309-7290
cgabica@harris.com

Hatch Mott MacDonald
Mr. Alex van Groenewoud
Deputy Practice Manager-Aviation
438 Main St., Ste. 700
Buffalo, NY 14051
Phone: (716)860-9306
Fax: (716)854-1800
Alex.vangroenewoud@hatchmott.com

HDS Retail North America
Mr. Gerry Savaria
EVP, Business Development
36 Toronto St., Ste. 1200
Toronto, ON M5C 2C5
Canada
Phone: (416)863-6400, Ext. 310
Fax: (416)863-6552
gsavaria@hdsrna.com

Heery International, Inc.
Mr. Joseph P. Bellanca, P.E.
Vice President
999 Peachtree St. NE
Atlanta, GA 30309-3955
Phone: (404)946-2551
Fax: (404)875-1283
jbellanca@heery.com

The Hertz Corporation
Mr. Simon H.P. Ellis
V.P., Properties & Concessions
225 Brae Blvd.
Park Ridge, NJ 07656-0713
Phone: (201)307-2771
Fax: (201)307-2689
sellis@hertz.com

HMSHost
Mr. Les Copetta
Executive Vice President
6905 Rockledge Dr.
Bethesda, MD 20817-1806
Phone: (240)694-4195
Fax: (240)694-4631
Les.copetta@hmshost.com

HNTB Corporation
Mr. Evan C. Futterman
Chairman, Aviation Services
2900 South Quincey St., Ste. 200
Arlington, VA 22206
Phone: (703)824-5100
Fax: (703)671-6307
efutterman@hntb.com

Hogan & Hartson LLP
Ms. Aletha N. Nancoo
Partner
555 Thirteenth St., NW
Washington, D.C. 20004
Phone: (202)637-5600
Fax: (202)637-5910
annancoo@hhlaw.com

Honeywell International
Mr. Todd McNabb
Segment Leader, Airports
1600 Uica Ave. S., Ste. 300
Minneapolis, MN 55416
Phone: (952)656-1698
Fax: (952)656-1298
todd.mcنabb@honeywell.com

Hoyle, Tanner & Associates, Inc.
Mr. J. Richard Luddens, C.M.
Senior Vice President
150 Dow St.
Manchester, NH 03101-1227
Phone: (603)669-5555
Fax: (603)669-4168
rluddens@hta-nh.com

Hudson Group
Mr. Michael R. Mullaney
Senior Vice President, Business Development
One Meadowlands Plaza
East Rutherford, NJ 07073
Phone: (201)939-5050
Fax: (201)939-1353
mmullaney@hudsongroup.com

Hunt Construction Group Inc.
Mr. Chris Hadley
Communications Coordinator
2450 South Tibbs Ave.
Indianapolis, IN 46241
Phone: (317)227-7800
Fax: (317)227-7810
chadley@huntonconstructiongroup.com

IMB Corporation
Mr. David Brown
Account Manager-U.S. Dept. of Transportation
6710 Rockledge Drive
Bethesda, MD 20817
Phone: (301)803-3298
David.c.clarke@us.ibm.com

Infrastructure Management Group, Inc.
Mr. Jorge A. Gonzalez
Vice President
4733 Bethesda Ave., Ste. 600
Bethesda, MD 20814-5251
Phone: (301)907-2900
Fax: (301)907-2906
jgonzalez@imggroup.com

International RAM Associates
Ms. Cassandra N. Beamer
Director, Government & Industry Affairs
14000 Thunderbolt Pl.
Building R
Chantilly, VA 20151
Phone: (703)955-7890
Fax: (512)345-1096
cbeamer@infram.com

Sponsor Directory

Interspace Airport Advertising

Ms. Marianne Lieberman
Co-CEO
4635 Crackenport Rd.
Allentown, PA 18104-9553
Phone: (610)395-8002
Fax: (610)395-4450
mlieberman@iasa.com

Jacobs Consultancy
Mr. Mark E. Lunsford
Managing Director
555 Airport Blvd., Ste. 300
Burlingame, CA 94010
Phone: (650)579-7722
Fax: (650)343-5220
inquiry@jacobs-consultancy.com

Jacobs Engineering
Mr. Jeffrey V. Moak
Vice President - Aviation
5757 Plaza Dr., Ste. 100
Cypress, CA 90630
Phone: (714)503-3690
Fax: (714)503-3999
jeff.moak@jacobs.com

Kennedy/Jenks Consultants
Mr. Steve L. Strenchberry, AICP
V.P.-Director, Airport Services
622 Folsom St.
San Francisco, CA 94107
Phone: (415)243-2463
Fax: (415)896-0999
stevenstrenchberry@kennedyjenks.com

Kimley-Horn and Associates, Inc.
Mr. Michael Carey, P.E.
Project Manager
5200 NW 33rd Ave. Ste. 109
Fort Lauderdale, FL 33309-6399
Phone: (954)535-5108
Fax: (954)739-2247
michael.carey@kimley-horn.com

L-3 Communications Security & Detection Systems
Ms. Sandra DeSantis
Global Events Manager
Woburn, MA 01801-1028
Phone: (781)939-3985
Fax: (781)939-3996
sandra.desantis@l3.com

Landrum & Brown, Inc.
Mr. Mark A. Perryman
President
11279 Cornell Park Dr.
Cincinnati, OH 45242
Phone: (513)530-5333
Fax: (513)530-1278
mperryman@landrum-brown.com

The Lane Construction Corporation
Mr. Robert Alger
President
965 East Main St.
Meriden, CT 06450
Phone: (203)235-3351
Fax: (203)237-4260
ralger@lanconstruct.com

Leo A. Daly Co.
Mr. Keith G. Mawson
V.P. Aviation Services
1170 Peachtree St., NE, Ste. 1600
Atlanta, GA 30309
Phone: (404)874-8333
Fax: (404)874-8330
kgmawson@leodaly.com

Linc Facility Services

Mr. Jeffrey T. Hoff
Director of Sales, Aviation
1701 Louisiana St., Ste. 2700
Excelsior, MN 55331
Phone: (952)380-5023
Fax: (952)380-5024
Jeffrey.Hoff@lincfs.com

Lockheed Martin
Monte Belger
Vice President, Transportation Systems Solutions
9231 Corporate Blvd.
Rockville, MD 20850
Phone: (301)640-4391
Fax: (301)640-2498
Monte.belger@lm.com

The LPA Group Incorporated
Mr. Ken Holt
Vice President
P.O. Box 5805
Columbia, SC 29250
Phone: (803)254-2211
Fax: (803)779-9341
kholt@lpagroup.com

Mead & Hunt, Inc.
Mr. Andy Platz
Vice President, Manager of Aviation Services
6501 Wans Rd.
Madison, WI 53719-2700
Phone: (608)273-6380
Fax: (608)273-6391
Andy.platz@meadhunt.com

Memphis-Shelby County Airport Authority
Memphis International Airport
Mr. Larry D. Cox, A.A.E.
President & CEO
2491 Winchester Rd., Ste. 113
Memphis, TN 38116-3856
Phone: (901)922-8077
Fax: (901)922-8099
larryc@mscaa.com

Metro Washington Airports Authority
Mr. James E. Bennett, A.A.E.
President & CEO
1 Aviation Circle
Washington, D.C. 20001-6000
Phone: (703)417-8610
Fax: (703)417-8949
james.bennett@mwaa.com

Midwest Air Traffic Control Service Inc
Mr. Shane L. Cordes
President & CEO
13200 Metcalf Ave., Ste. 110
Overland Park, KS 66213
Phone: (913)782-7082
Fax: (913)897-9300
ShaneLC@mt.net

Northeast Chapter AAAE
Mr. Richard J. Williams, A.A.E.
Executive Secretary
P.O. Box 8
West Milford, NJ 07480
Phone: (973)728-9048
Fax: (973)728-6760
ewr103@optonline.net

Northwest Chapter AAAE

Linda Tepper
Executive Secretary
P.O. Box 1054
Klamath Falls, OR 97601
Phone: (541)883-5372
Fax: (541)883-5376
lmt@klamathfallsairport.com

O.R. Colan Associates
Mr. Theodore M. Pluta
Vice President
439 NE 7th Ave.
Ft. Lauderdale, FL 33477-5561
Phone: (954)765-5700
Fax: (954)463-3017
tpluta@orcolan.com

Odeff Associates, Inc.
Mr. Robert G. Griffin, AIA
Chairman
800 Weng Hill St., Third Fl.
Charlotte, NC 28208
Phone: (704)414-1000
Fax: (704)414-1111
griffin@odeff.com

The Paradies Shops, Inc.
Mr. Richard Dickson
Chairman
5950 Fulton Industrial Blvd.
Atlanta, GA 30336-2717
Phone: (404)344-7905
Fax: (404)349-3226
dick.dickson@theparadiesshops.com

Parsons Corporation
Jeff Sutton
Vice President and Manager Mission Support Sector
1133 15th St., NW
Washington, D.C. 20005
Phone: (202) 775-3300
Fax: (202) 775-6080
jeffrey.sutton@parsons.com

Parsons Management Consultants, a joint venture of Parsons Corporation, DMJM Aviation, PB Americas, Inc., and Delon Hampton and Associates, Chartered
Bruce L. Swanson
Program Manager
45045 Aviation Drive
Suite 200
Dulles, VA 20166
Phone: 703-572-1127 (Phone)
Fax: 703-572-1130 (Fax)
bruce.swanson@mwaa.com

Patton Boggs L.L.P.
Mr. John Oberdorfer
Partner
2550 M St., NW
Washington, D.C. 20037
Phone: (202)457-6000
Fax: (202)457-6315
joberdorfer@pattonboggs.com

PB Americas, Inc.
Mr. A. Bradley Mims
Vice President
1401 K St., NW, Ste. 701
Washington, D.C. 20005
Phone: (202)661-9263
Fax: (202)783-0229
mims@pbworld.com

PBS&J

Mr. Wayne J. Overman, P.E.
Senior Vice President
402 BNA Drive, Ste. 350
Nashville, TN 37217-2025
Phone: (615)399-0298
Fax: (615)399-0361
wjoeverman@pbsj.com

Phoenix Sky Harbor International Airport

Mr. Carl D. Newman, A.A.E.
Assistant Aviation Director
Phoenix, AZ 85034-4403
Phone: (602)273-2751
Fax: (602)273-4084
carl.newman@phoenix.gov

PLANT/CML

Mr. Dave Sorg
V.P., Special Markets
42505 Rio Nedo
Temecula, CA 92590
Phone: (951)719-2100
Fax: (951)296-2727
dsorg@plantcml.com

Reno-Tahoe Airport Authority

Ms. Krys T. Bart, A.A.E.
Executive Director
P.O. Box 12490
Reno, NV 89510-2490
Phone: (775)328-6402
Fax: (775)328-6414
kbart@renoairport.com

Reveal Imaging Technologies, Inc.

Mr. Stephen M. Pelham
Director, U.S. Sales
201 Burlington Rd.
Bedford, MA 01730
Phone: (781)276-8400
Fax: (781)276-8410
stephen.pelham@revealimaging.com

Reynolds, Smith & Hills, Inc.

Mr. Brian P. Reed
Executive Vice President
10748 Deerwood Park Blvd., S
Jacksonville, FL 32256
Phone: (904)256-2266
Fax: (904)256-2502
brian.reed@rsandh.com

Ricondo & Associates, Inc.

Mr. James T. Jarvis
Sr. Vice President
20 North Clark Street, Ste. 1500
Chicago, IL 60602
Phone: (703)519-2181, Ext. 230
Fax: (703)519-2184
j.jarvis@ricondo.com

Robinson Aviation (RVA) Inc.

Mr. Charles H. Dove
President
9998 Wakeman Dr.
Manassas, VA 20110
Phone: (703)366-3138
Fax: (703)369-2185
charlie.dove@rvainc.net

Sensis Corporation

Ms. Anna Avsitidisky
Marketing/Communications
5717 Enterprise Pkwy.
DeWitt, NY 13214
Phone: (315)445-0550
Fax: (315)446-2209
anna@sensis.com

Serco, Inc.

Mr. Stephen T. Christmas
Vice President, Aviation
633 E. Vine St.
North Charleston, SC 29405
Phone: (843)820-2400 X 19
Fax: (843)820-2414
steve.christmas@serco-na.com

Siemens

Ms. Stacy L. Hollowell
Senior Marketing Manager
8600 N. Royal La.
Irving, TX 75603
Phone: (972)621-5754
Fax: (770)225-5633
stacy.hollowell@siemens.com

Signature Flight Support

Ms. Mary M. Miller
V.P., Customer Relations
Ronald Reagan National Airport
General Aviation Terminal
Hanger 7
Washington, D.C. 20001
Phone: (703)417-3540
Fax: (703)417-3541
mary.miller@signatureflight.com

Skanska USA Building Inc.

Ms. Catherine L. Pfeifferberger
Executive Vice President of Business Development
136 Madison Ave.
New York, NY 10016
Phone: (917)438-4500
Fax: (917)438-4599
catherine.pfeifferberger@skanskausa.com

South Central Chapter AAAE

Mr. Jeff L. Bilyeu, A.A.E.
Executive Director
Lone Star Executive Airport
10260 Carl Pickering Dr.
Conroe, TX 77381
Phone: (936)788-8311
Fax: (936)760-6993
jbilyeu@co.montgomery.tx.us

Southeast Chapter AAAE

Mr. Robert Brammer
Executive Secretary
8712 Caspiana Lane
North Charleston, NC 29420
Phone: (843)425-3878
Fax: (843)225-1733
Secaaae.aol.com

Southwest Chapter AAAE

Mr. Gary Rice
President
P.O. Box 4228
Sparks, NV 89432
Phone: (805)922-1726
Fax: (805)922-0677
grice@santamariaairport.com

Stantec Consulting, Inc.

Mr. James E. McLaughlin, P.E.
Associate, Transportation
22 Free St.
Portland, ME 04101-3900
Phone: (207)775-3211
Fax: (207)775-6434
jim.mclaughlin@stantec.com

SuperShuttle International, Inc.

Ms. Judy Robertson
V.P., Regulatory Affairs
14500 N. Northsight Blvd., Ste. 329
Scottsdale, AZ 85260
Phone: (805)496-7022
Fax: (805)496-1852
jrobertson@supershuttle.net

Technical & Professional Services, Inc. (TAPS)

Ms. Donna Brock
President
1915 Old New Windsor Pk.
New Windsor, MD 21776
Phone: (410)840-9121
Fax: (410)635-3203
tapsinc900@aol.com

TransCore

Mr. Forrest M. Swensen
Director, Airport Systems & Services
19119 Dallas Pkwy, Ste.300
Dallas, TX 75287
Phone: (972)733-6479
Fax: (972)733-6425
forrest.swensen@transcore.com

Transtech Airport Solutions Inc.

Ms. Sharon Lanis
Marketing Communications Specialist
600 Hayden Station Rd.
Windsor, CT 06095
Phone: (860)285-0387
Fax: (860)285-0673
sharon.lanis@transtech-as.com

URS Corporation

Mr. Laddie E. Irion
Vice President/Director, Air Transportation
7650 West Courtney Campbell Cswy.
Tampa, FL 33607-1462
Phone: (813)636-2425
Fax: (813)636-2400
laddie_irion@urscorp.com

Washington Airports Task Force

Ms. Anita Kayser
Director Aviation Policy
44701 Propeller Court, Ste. 100
Dulles, VA 20166
Phone: (703)572-8714
Fax: (703)572-8418
anita@washingtonairports.com

Wetland Studies & Solutions, Inc.

Mr. Michael S. Rolband
President
5300 Wellington Branch Dr.
Gainesville, VA 20155
Phone: (703)679-5602
Fax: (703)679-5601
mrolband@wetlandstudies.com

Woodward & Associates

Ms. Woodie Woodward
President
2005 Grandy Blvd., Ste. 600
St. Petersburg, FL 33702
Phone: (727)556-0270
Fax: (727)510-1997
woodwardwsh@aol.com

AMERICAN ASSOCIATION
OF AIRPORT EXECUTIVES
DISTINGUISHED SERVICE
AWARD (DSA) WINNERS

- 1990 *(first year it was awarded)*
George Bean, Tampa, Florida
Robert Shea, Cleveland, Ohio
Henry Stuart, Dallas, Texas
Robert Ross, Grand Rapids, Michigan
- 1991 Bob Michael, Louisville, Kentucky
John Solomon, Kansas City, Missouri
- 1992 Jack Armour, Boston, Massachusetts
John Gwinn, Lewisburg, West Virginia
Don Smith, Seattle, Washington
- 1993 Paul Gaines, Houston, Texas
- 1994 Ralph Tonseth, San Jose, California
Larry Hedrick, Columbus, Ohio
- 1995 Bob Waddle, Columbia, South Carolina
Dutch Bertholf, Phoenix, Arizona
- 1996 Jerry FitzGerald, New York, New York
Hal Wight, Concord, California
- 1997 Mike Kutchins, San Antonio, Texas
Lowell Pratte, Louisville, Kentucky
- 1998 Robert D. Hancik, Springfield, Missouri
Thomas W. Schmidt, Lansing, Michigan
- 1999 James Thorsen, Idaho Falls, Idaho
Peter L. Drahn, Madison, Wisconsin
- 2000 John C. Schalliol, South Bend, Indiana
J. Bruce Putnam, Billings, Montana
- 2001 James McCue, Glendale, Arizona
Larry D. Cox, Memphis, Tennessee
- 2002 James L. Morasch, Pasco, Washington
Timothy Campbell, Salt Lake City, Utah
- 2003 Sam Hoerter, Charleston, South Carolina
Alfred J. Graser, New York, New York
- 2004 Loretta A. Scott, Grand Prairie, Texas
James A. Koslosky, Grand Rapids, Michigan
- 2005 Thomas E. Greer, Monterey, California
Bonnie A. Allin, Tucson, Arizona
- 2006 Thomas H. Binford, Billings, Montana
Kent G. George, Pittsburgh, Pennsylvania

AAAE ACCREDITED MEMBERS APRIL 2006-MAY 2007

The AAAE Board of Directors and the Board of Examiners wish to congratulate the following members who successfully completed the accreditation program between April 2006 and May 2007:

- Mr. Scott M. Ayers, A.A.E., ACE,
Fayetteville, GA
- Ms. Kim M. Berry, A.A.E., Milwaukee, WI
- Mr. Jeff L. Bilyeu, A.A.E., Conroe, TX
- Mr. Timothy T. Bradshaw, A.A.E.,
Owensboro, KY
- Mr. Barry C. Bratt, A.A.E., Redding, CA
- Mr. Cyrus T. Callum, A.A.E., ACE,
Jacksonville, FL
- Mr. Teakoe S. Coleman, A.A.E.,
Alexandria, VA
- Mr. Tey Coleman, A.A.E., Fayetteville, NC
- Ms. Melinda C. Crawford, A.A.E.,
Pensacola, FL
- Mr. Benjamin R. DeCosta, A.A.E.,
Atlanta, GA
- Mr. Rod A. Dinger, A.A.E., Redding, CA
- Mr. Shawn A. Dobberstein, A.A.E., Fargo, ND
- Mr. Michael P. Feeley, A.A.E., Manassas, VA
- Ms. Rosalyn France, A.A.E., San Jose, CA
- Mr. Al Gulamali, A.A.E., Cape Coral, FL
- Ms. Angie Highland, A.A.E., Fort Worth, TX
- Mr. Robert Kelley, A.A.E.,
Fort Lauderdale, FL
- Mr. Mark D. Kranenburg, A.A.E.,
Oklahoma City, OK
- Mr. Michael B. Laven, CPA, A.A.E.,
Pensacola, FL
- Ms. Mica Lombrana, A.A.E., El Paso, TX
- Mr. Francis T. Maguire, A.A.E., Norwood, MA
- Mr. Derek V. Martin, A.A.E., Rockford, IL
- Mr. Mark H. Mellinger, A.A.E., Bentonville,
AR
- Mr. Roy H. Miller Jr., A.A.E., Shreveport, LA
- Ms. Teri A. Norcross, A.A.E., Missoula, MT
- Mr. Jerry O'Sullivan, A.A.E., Lewisburg, WV
- Mr. John E. Parrott, A.A.E., Anchorage, AK
- Mr. Rodney Propst, A.A.E., Fullerton, CA
- Mr. Ryan E. Rocha, A.A.E., San Antonio, TX
- Mr. David A. Ruch, A.A.E., Minneapolis, MN
- Mr. Anthony M. Rudy, A.A.E., Ithaca, NY
- Mr. Kenneth E. Simmons, A.A.E.,
Rapid City, SD
- Mr. Mihai Smighelschi, A.A.E., Knoxville, TN
- Mr. Marshall B. Stevens, A.A.E.,
Queensbury, NY
- Mr. Jeffrey S. Tripp, A.A.E., Mesa, AZ
- Mr. Michael G. Trout, A.A.E., Flint, MI
- Mr. Kevin G. Vandenberg, A.A.E.,
Huntsville, AL
- Ms. Beverley M. Vassell, A.A.E., Fletcher, NC
- Mr. James G. Walsh, A.A.E.,
BWI Airport, MD
- Mr. L. Clint Welch, A.A.E., San Diego, CA
- Ms. Sara A. Young, A.A.E., Cedar Rapids, IA

AAAE Foundation Benefit and HG ISBILL Endowment Fund
Luncheon on Monday, June 11 and Foundation Benefit and HG
ISBILL Endowment Fund Prize Drawings, Tuesday, June 12

This year, the Monday Luncheon, from noon to 1:30 p.m. in Ballroom A/B, will be dedicated to advancing the work of the AAAE Foundation Scholarship and HG Isbill Endowment Fund. Please purchase your tickets at the registration desk for the Foundation and HG Isbill Endowment Fund Benefit prize drawings to be held in the AAAE Showcase from 10:30-11:30 a.m. on Tuesday, June 12. Tickets are \$35—the more you buy, the better your chances are to win! For every three chances you purchase, you will receive one additional free ticket. Prizes include airline tickets, hotel stays and many more exciting items. The grand prize drawing is for a trip to the 2008 Aviation Issues Conference, January 6-10, in Kona, Hawaii! You must be present to win.

79TH ANNUAL CONFERENCE COMMITTEE

CONFERENCE HOST

James E. Bennett, A.A.E.
President/CEO
Metropolitan Washington Airports Authority

CONFERENCE PROGRAM CHAIR

Jonathan Gaffney
Vice President, Communications
Metropolitan Washington Airports Authority

CONFERENCE PLANNING CHAIR

Margaret A. Bishop
Manager, Community Relations
Metropolitan Washington Airports Authority

CONFERENCE COMMITTEE

Cassandra N. Beamer, Chantilly, Virginia
Jeff L. Bilyeu, A.A.E., Conroe, Texas
Tracie L. Blaser, C.M., Nashville, Tennessee
Roddy L. Boggus, Dallas, Texas
Scott A. Brockman, A.A.E., Memphis, Tennessee
Gerald Buckwalter, Arlington, Virginia
Bruce E. Carter, A.A.E., Moline, Illinois
Mark F. Courtney, A.A.E., Lynchburg, Virginia
Kim P. Dickie, C.M., San Francisco, California
Karen W. Ellis, Atlanta, Georgia
Edward P. Faberman, Washington, D.C.
Scott D. Hinderman, A.A.E., Fort Wayne, Indiana
Levert Hood, C.M., College Park, Georgia
Michael R. Humbert, A.A.E., Topeka, Kansas
Charles J. Isdell, A.A.E., Philadelphia, Pennsylvania
Marilyn Mora, C.M., Reno, Nevada
Klaasje Nairne, C.A.E., C.M., San Luis Obispo, California
Robert W. O'Brien, Jr., A.A.E., Rockford, Illinois
Mark Pesce, Philadelphia, Pennsylvania

Lisa A. Pyles, A.A.E., Addison, Texas
Torrance A. Richardson, A.A.E., Fort Wayne, Indiana
Regina M. Roberts, Dayton, Ohio
Dr. Gregory L. Schwab, C.M., Ed.D., Brazil, Indiana
Sharon L. Sears, Vandalia, Ohio
Delores J. Singletary, Newark, New Jersey
Michael D. Stewart, Jacksonville, Florida
Allan V. Straughan, Laurel, Maryland
Alvin L. Stuart, A.A.E., Salt Lake City, Utah
Beverly M. Vassell, A.A.E., Fletcher, North Carolina
Craig A. Williams, A.A.E., Fort Wayne, Indiana

METROPOLITAN WASHINGTON AIRPORTS
AUTHORITY BOARD OF DIRECTORS

CHAIRMAN

Mame Reiley

VICE CHAIRMAN

The Honorable H.R. Crawford

James L. Banks, Jr.
Robert Clarke Brown
The Honorable William W. Cobey, Jr.
Anne Crossman
Mamadi Diané
Michael David Epstein
Weldon H. Latham
Leonard Manning
Michael L. O'Reilly
Charles D. Snelling
The Honorable David G. Speck

Performing during Monday's opening session will be Sandburg Middle School's Choralettes, an auditioned choir comprised of 7th and 8th grade young women. They consistently receive superior ratings at festival and Music in the Park trips. The Choralettes have performed at such venues as West Potomac High School, Reagan National Airport, Fairfax County School Board meetings and the Virginia Music Educators Conference at the Homestead. The school has received the Virginia Blue Ribbon school award for the past four years. The Metropolitan Washington Airports Authority is proud to present the Choralettes from Carl Sandburg Middle School, our oldest school partner.

Performing during Sunday's evening event at the Udvar-Hazy Center will be The Stone Bridge Jazz Ensemble, an auditioned performance ensemble from Stone Bridge High School in Ashburn, VA. The band performed at the 2006 Cotton Bowl in Dallas, Texas. They have received superior ratings at the District Jazz Festival for six out of seven years as well as at the Festivals of Music in Chicago this year. They have won numerous first and second place awards at annual trips in Chicago, Dallas, St. Louis, and Orlando. The Airports Authority is proud of its partnership with Stone Bridge High School and is pleased to present its Jazz band at the Udvar-Hazy Center.

Airport

M A G A Z I N E

would like to thank the following companies for their advertising support in the 2007 Annual Conference Issue

AAAE	Giuliani Associates Architects, Inc.	PB
Analogic Corp.	HDS Retail North America	PBS&J
Aviation Capital Management	HMSHost Corp.	PSSI
Burns & McDonnell	HNTB Corporation	QinetiQ
Carter & Burgess Inc.	Honeywell International, Inc.	Reveal Imaging Technologies, Inc.
CH2M HILL	Hudson Group	Reynolds Smith & Hills, Inc.
CLEAR Verified Identity Pass, Inc.	Hurley Corporation Inc.	Ricondo & Associates, Inc.
CPI Daylighting, Inc.	Tilt-A-Way / Ideal Manufacturing	Rosenbauer America
Daktronics Inc.	IMDC, Inc.	Serco Inc.
Delta Airport Consultants, Inc.	Kimley-Horn & Associates, Inc.	Siemens
DME Corporation	KJM & Associates	Signature Flight Support
Earth Tech	Klondike Kidstuff Inc.	Stantec
ESA Airports	Linc Facility Services	Swift Conference
Engineered Arresting Systems Corp. (ESCO-ZODIAC)	The LPA Group	The Escalator Cleaning Company
EQ Airport Services	Magal-Senstar, Inc.	TransCore
Federal APD, Inc.	Michael Baker Jr. Inc.	Transoft Solutions Inc.
First Southwest Co.	OAG Worldwide, Inc.	Transpo Industries, Inc.
Flex-O-Lite, Inc.	Off the Wall Products, LLC	Wings Financial
	Oskosh Truck Corporation	

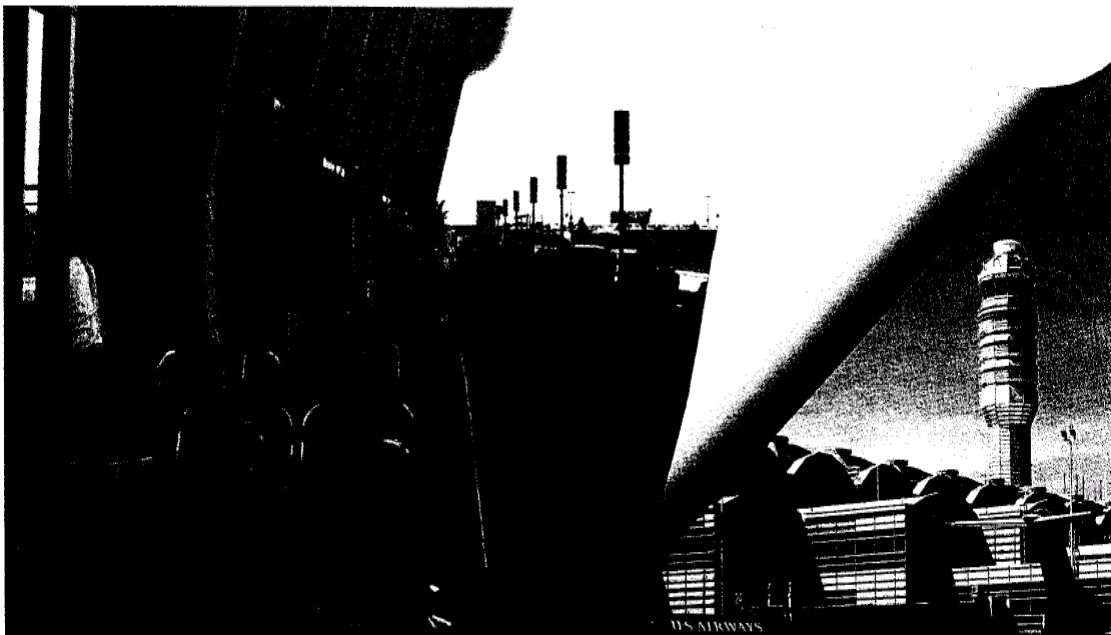

Year	President/Chairs	City/State
1928	E.A. Johnson	Dayton, Ohio
1929	John Berry	Cleveland, Ohio
1930	B.E. Fulton	Akron, Ohio
1931	R.B. Barnitz	Los Angeles, California
1932	R.B. Barnitz	Los Angeles, California
1933	Steadman Acker	Birmingham, Alabama
1934	Steadman Acker	Birmingham, Alabama
1935-1938 (Inactive Years)		
1939	I.J. Deinhart	Indianapolis, Indiana
1940	C.V. Burnett	Detroit, Michigan
1941	Ralph Page	St. Louis, Missouri
1942	Howard Shafer	Philadelphia, Pennsylvania
1943	Charles Hanst	Dallas, Texas
1944	Charles Hanst	Dallas, Texas
1945	Charles Hanst	Dallas, Texas
1946	Woodruff DeSilva	Los Angeles, California
1947	Neil Brackstone	Lansing, Michigan
1948	Douglas Langstaff	New Orleans, Louisiana
1949	Don Martin	Wilmington, Delaware
1950	Melvin H. Nuss	Reading, Pennsylvania
1951	Walter E. Bertsworth	Waterloo, Iowa
1952	C.C. Meadows	Bakersfield, California
1953	F.A. Bolton	Columbus, Ohio
1954	William G. Fuller	Fort Worth, Texas
1955	Leslie A. Bryan	Urbana, Illinois
1956	John A. Casey	Chicago, Illinois
1957	R. W. F. Schmidt	Tucson, Arizona
1958	Henry Julliard	Louisville, Kentucky
1959	Edward L. Colby	Lubbock, Texas
1960	G. Edwin Petro	Indianapolis, Indiana
1961	Frank S. Pittenger	Syracuse, New York
1962	Robert Crisp	Little Rock, Arkansas
1963	Wilmer J. Garrett	Fresno, California
1964	Vincent Carson	Newark, New Jersey
1965	Arven H. Saunders	San Antonio, Texas
1966	Francis T. Fox	Los Angeles, California
1967	James F. Byrne	Boston, Massachusetts
1968	Lee W. Wagener	Fort Lauderdale, Florida
1969	Austin B. Brough	Philadelphia, Pennsylvania

Year	President/Chairs	City/State
1970	Charles H. Broman	Tucson, Arizona
1971	George J. Bean	Tampa, Florida
1972	Joseph E. Coulter	Norman, Oklahoma
1973	Arthur J. Fallon	Buffalo, New York
1974	Eric A. Taylor	Las Vegas, Nevada
1975	Roy A. Bayless	Cape Coral, Florida
1976	George N. Kirk	Moline, Illinois
1977	H. P. 'Pete' Hill	Idaho Falls, Idaho
1978	Roger G. Sekadlo	Greensboro, North Carolina
1979	John D. Solomon	Las Vegas, Nevada
1980	Hugh R. Kelleher	Helena, Montana
1981	Robert C. Davidson	Los Angeles, California
1982	Daniel C. Orcutt	Indianapolis, Indiana
1983	C. P. Mangum	Greensboro, North Carolina
1984	John J. Dickerson	New York, New York
1985	Michael J. Kutchins	San Antonio, Texas
1986	Larry W. Hedrick	Buffalo, New York
1987	Richard C. Smith	Modesto, California
1988	Robert H. Waddle	Columbia, South Carolina
1989	James E. Johnson	Tampa, Florida
1990	Kent G. George	Moline, Illinois
1991	J. Bruce Putnam	Billings, Montana
1992	Ralph G. Tonseth	San Jose, California
1993	Gerald P. FitzGerald	New York, New York
1994	Timothy L. Campbell	Nashville, Tennessee
1995	John D. Armour	Boston, Massachusetts
1996	Neilson A. Bertholf, Jr.	Phoenix, Arizona
1997	Peter L. Drahn	Madison, Wisconsin
1998	Loretta A. Scott	Grand Prairie, Texas
1999	James L. Morasch	Pasco, Washington
2000	Larry D. Cox	Memphis, Tennessee
2001	James A. Koslosky	Grand Rapids, Michigan
2002	Gerald K. Olson	Cheyenne, Wyoming
	Thomas E. Greer	Monterey, California
2003	Bonnie Allin	Tucson, Arizona
2004	William G. Barkhauer	Morristown, New Jersey
2005	R. Lowell Pratte	Louisville, Kentucky
2006	Elaine Roberts	Columbus, Ohio



JUNE 8 - 11, 2008

**80TH
ANNUAL**

**AAAE
Conference
& Exposition**



**AIRPORTS
AND ALL THAT JAZZ**



New Orleans, Louisiana

For registration details, contact the AAAE Meetings Department
For exhibit details, contact the AAAE Sales and Marketing Department
703.824.0504 • www.aaae.org/annual2008 • aaameetings@aaae.org



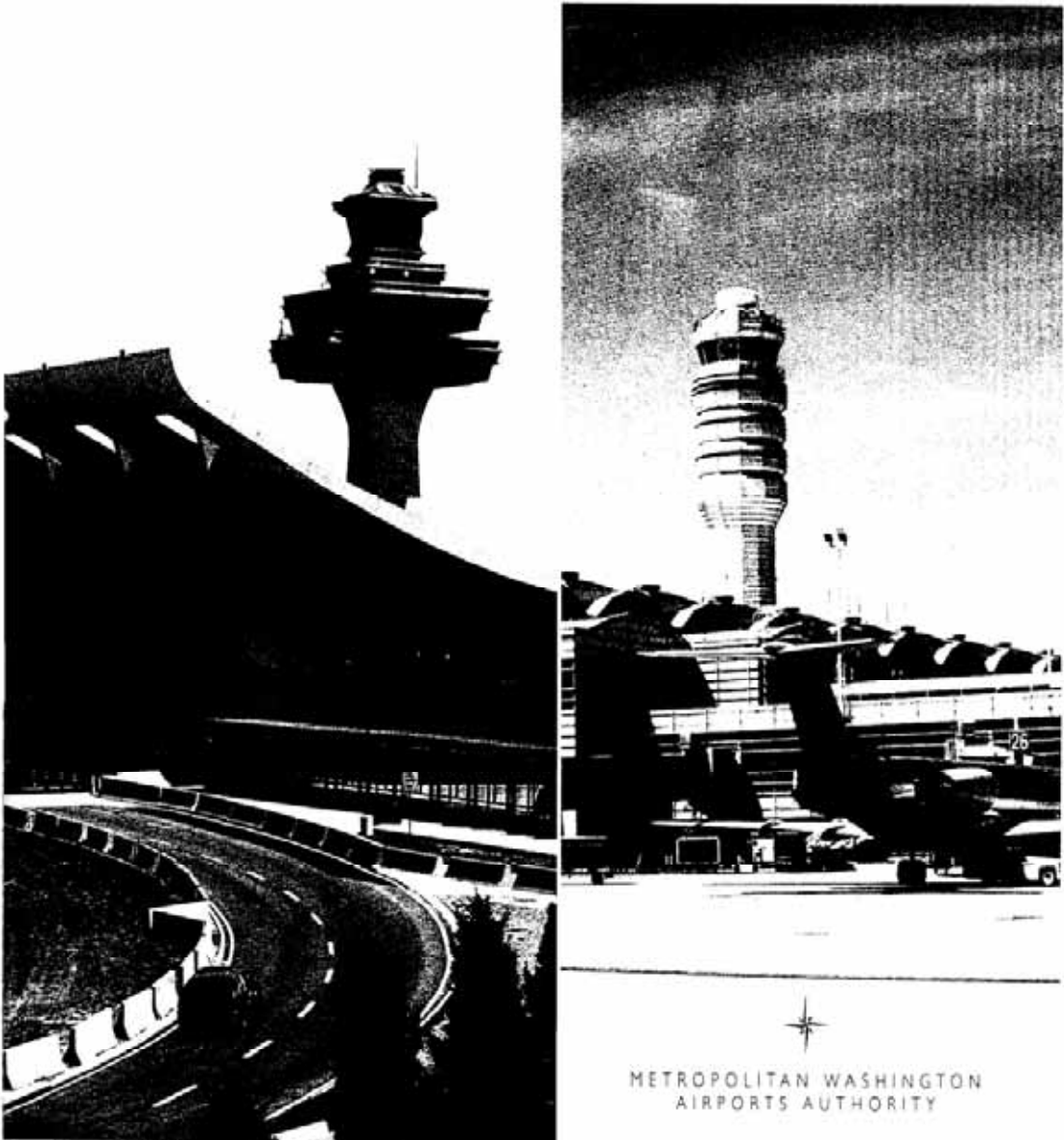

The Metropolitan Washington Airports Authority would like to thank the following Capital Club Sponsors for their generous support of the 79th Annual AAE Conference and Exposition

<p>Alpha Corporation Ammann & Whitney Giuliani Associates Architects Hogan & Hartson LLP</p>	<p>Infrastructure Management Group, Inc. The Lane Construction Corporation Parsons Management Consultants, a joint venture of Parsons Corporation, DMJM Aviation, PB Americas, Inc. and Delon Hampton and Associates, Chartered</p>	<p>URS Corporation Washington Airports Task Force</p>
---	---	--

Fly into the Future with Proven Partners

For five generations we've navigated the skies with innovative ideas. We've built automation systems that revolutionized air traffic control, and pioneered space-based navigation.

Today, Lockheed Martin is partnering with other inspired innovators forming its ADS-B team to help air traffic control leaders manage the demands of the future.

- **Sensis, Era, Harris and CSC**
Exceptional players in Surveillance and Information Services.
- **Parsons, IBM, ISI, URF and Embry-Riddle**
Respected names in Infrastructure Design, Deployment and Business Solutions.
- **Honeywell, ACSS and Duncan Aviation**
Avionics industry experts.

The Lockheed Martin Team

LOCKHEED MARTIN



HARRIS



IBM

EMBRY-RIDDLE
AERONAUTICAL UNIVERSITY

ACSS

DUNCAN
AVIATION

Honeywell

PARSONS

era
Beyond Radar

CSC
EXPERIENCE. RESULTS.

Sensis



The Lockheed Martin Team: A framework for change. A platform for the future.

All trademarks and registered trademarks are property of their respective owners. © 2007

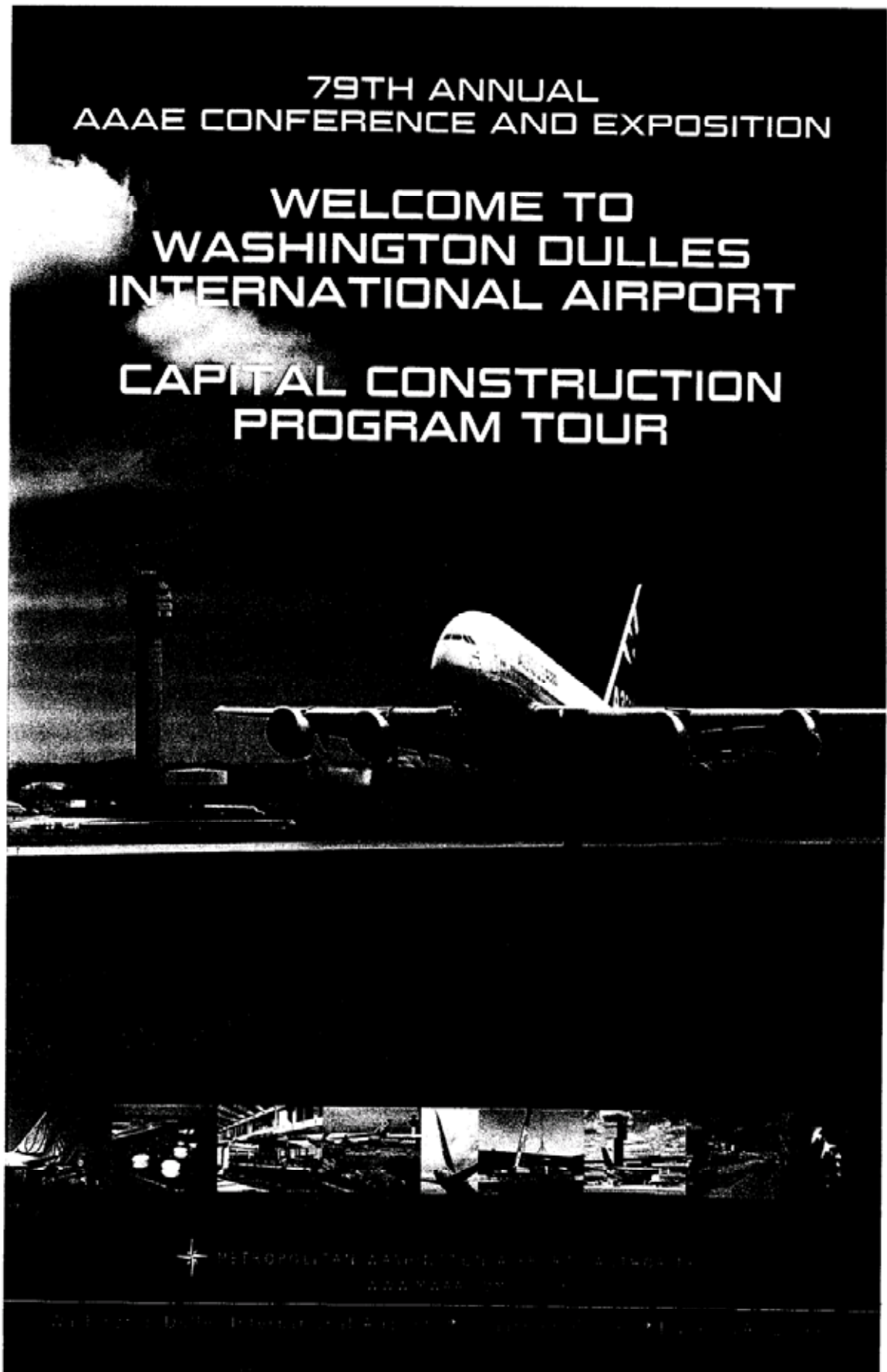



D2 DULLES DEVELOPMENT

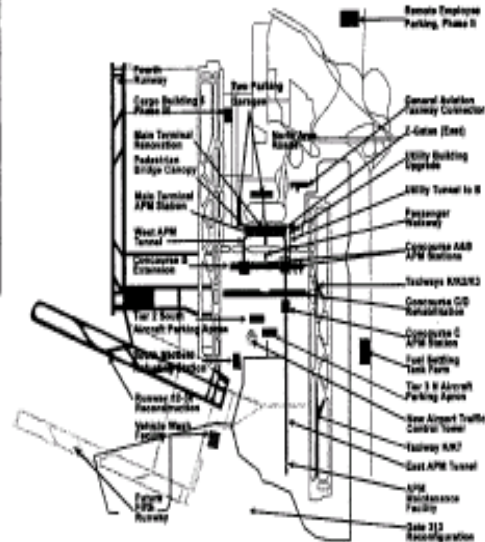

Welcome to Washington Dulles International Airport (IAD)

Dulles Development (D2) is the Metropolitan Washington Airports Authority's \$4 billion capital construction program for future growth—in passenger traffic and airport operations. The major D2 projects are designed to improve the traveling experience and accommodate increased use of the airport.

Growth projections for both passengers and aircraft operations highlighted the need for even more airport facilities in the future. In 2000, the Airports Authority Board of Directors approved a second phase of capital investment.

The D2 projects completed so far include two new Daily Parking Garages, passenger walkways with moving sidewalks connecting the garages to the Main Terminal and connecting the Main Terminal to Concourse B, reconstruction of Runway 12-30, new permanent Z-gates at the Terminal, and the renovation of the original 1962 Eero Saarinen-designed terminal, including improved ticketing counters and new baggage claim devices.

Projects currently underway include improving the roadways, expanding Concourse B, building a new Airport Traffic Control Tower, a new fourth Runway and constructing an automated Airport Train System and train stations. A new Security Mezzanine is also included in the construction of the Main Terminal Train Station.

"D2" Into the Future

Future D2 projects call for expanding the Z-gates, constructing a fifth runway, and building a new permanent Concourse beyond the present location of Concourse C and D. Dulles is in a constant state of evolution and improvement. The challenge for the Airports Authority is to continue to keep pace with growth in air service and meet the future traveling needs of the Washington region.

North Area Roadway Improvements – South Section



This project improves the eastbound Dulles Airport Access Highway lanes between Saarinen Circle and Route 28 to meet the traffic forecasts for 25 million annual passengers.

Notice to Proceed: March 2006
Substantial Completion: April 2008
Designer: Johnson, Mirmiran & Thompson
Contractor: Lane Construction Corporation

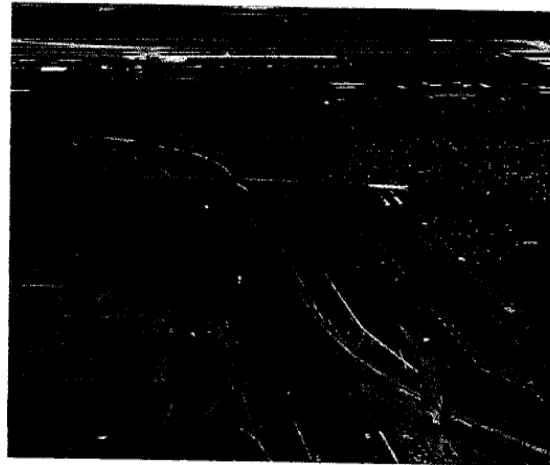
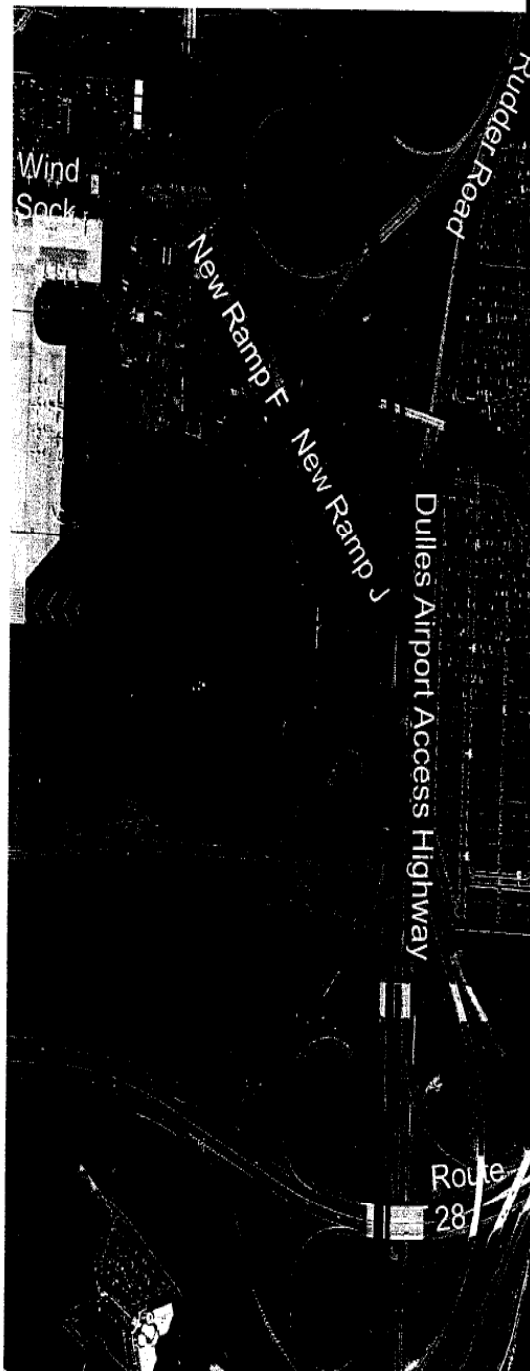

North Area Roadway Improvements – North Section



This project improves the westbound Dulles Airport Access Highway lanes between Route 28 and Saarinen Circle to meet the traffic forecasts for 25 million annual passengers.

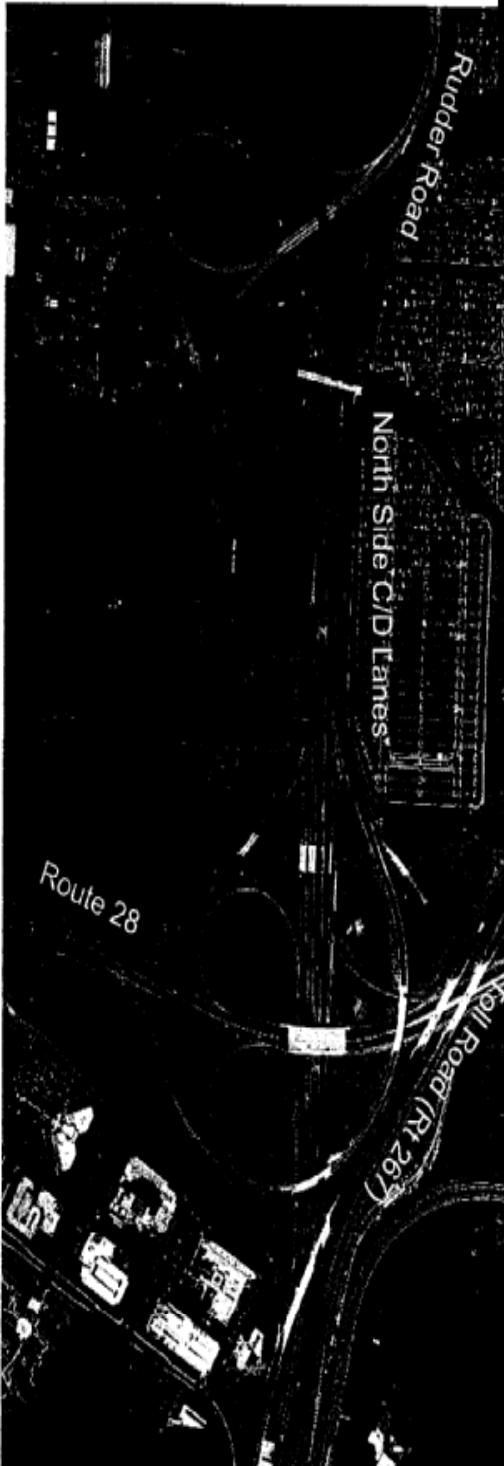

Notice to Proceed: August 2006
Substantial Completion: August 2008
Designer: Rajan Mahima Associates, Inc.
Contractor: Facchina Construction

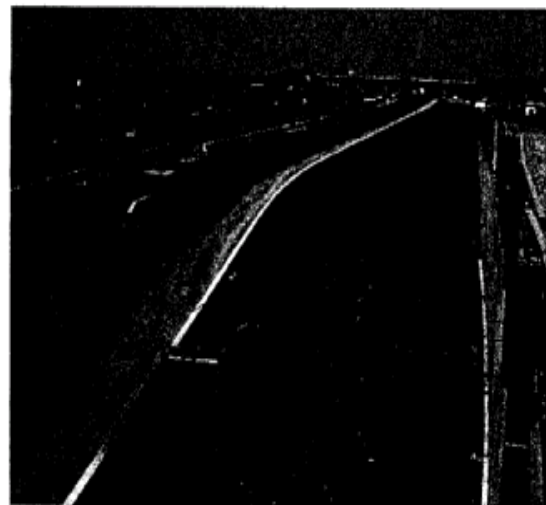

Fuel Settling Tank Farm General Construction



Provides infrastructure and supporting facilities for the Fuel Settling Tank Farm. Includes fuel systems, filters and fuel distribution lines, fire protection, roadways, fencing, water and sanitary distribution, storm system, and power and security systems.

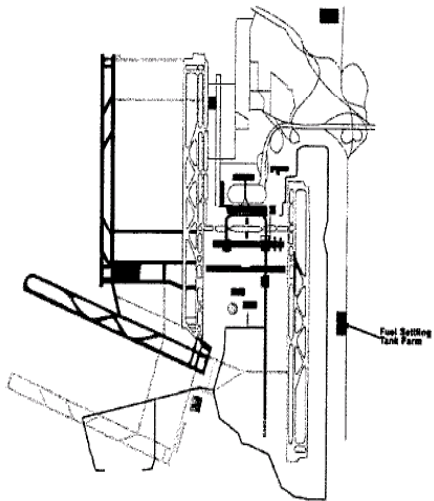

Notice to Proceed: May 2006
Substantial Completion: August 2007
Designer: Burns & McDonnell Engineering
Contractor: Grunley-Walsh, LLC

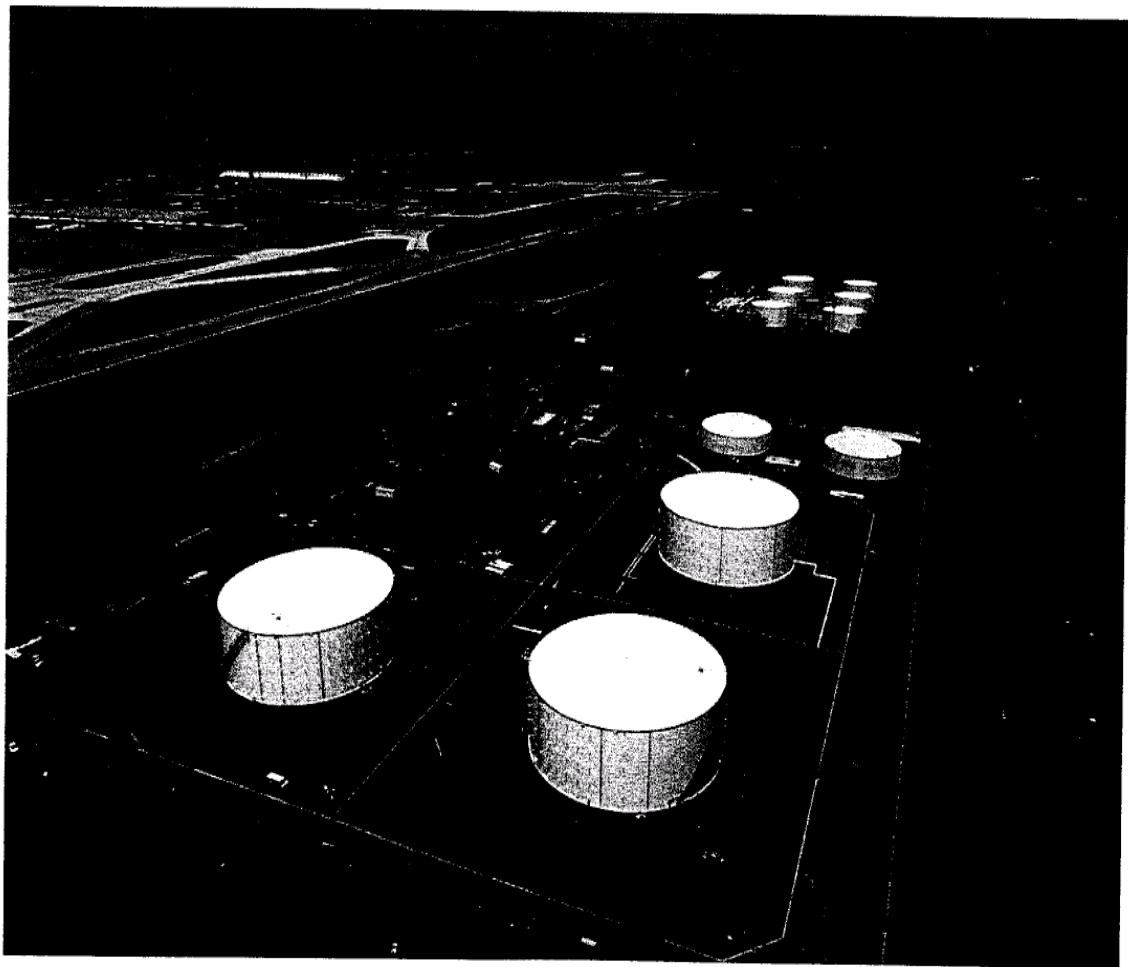

AeroTrain Maintenance Facility



An above ground automated people mover vehicle maintenance facility and switchyard located southwest of Runway 1R. Facility provides maintenance space for 18 cars, storage for parts, supplies and shops, mechanical and electrical equipment rooms, offices and the main AeroTrain Operations Control Center.

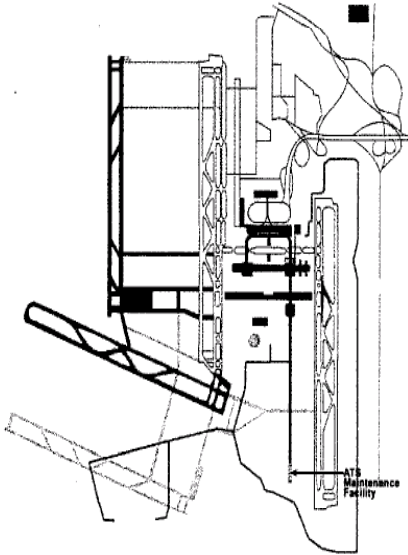

Notice to Proceed: July 2004
Substantial Completion: May 2006
Designer: HNTB Corporation
Contractor: Turner Construction

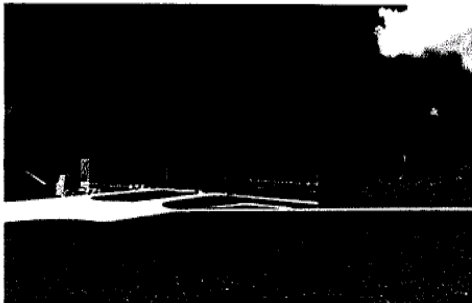

AeroTrain Automated People Mover System



Supplies the Automated People Mover System from the Main Terminal to the Concourses and future Tier 2. This contract includes trains, guideways and control systems.

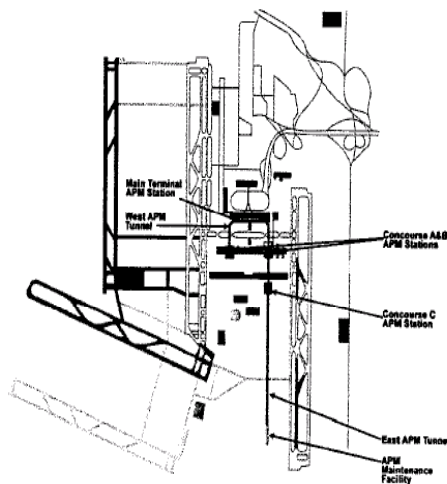

Notice to Proceed: March 2003
 Substantial Completion: July 2009
 Design/Build: Sumitomo Corporation of America

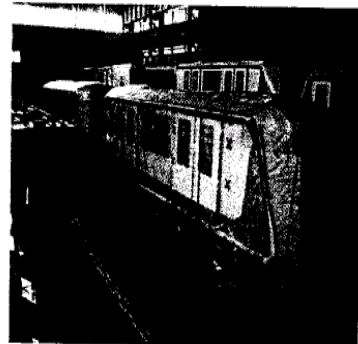

The first four AeroTrain cars, and the Maintenance/Recovery Vehicle, left the Mitsubishi factory in Japan on April 8, 2007, and were loaded onto a ship for transport to the United States

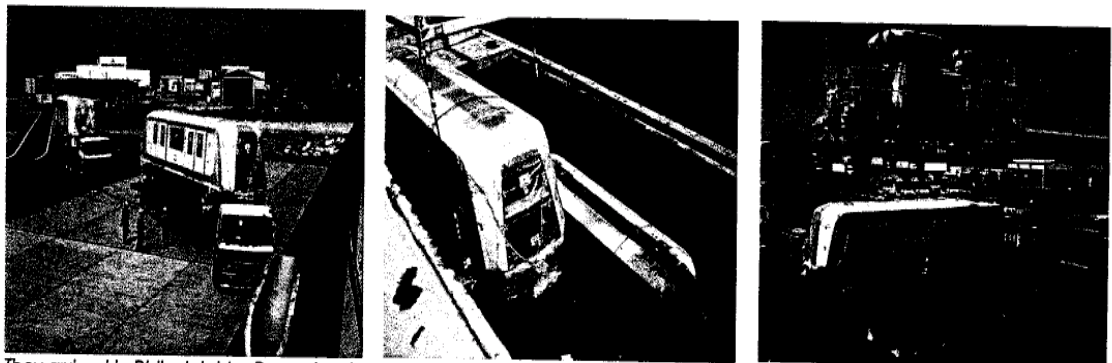

They arrived in Philadelphia, Pennsylvania, on May 22, 2007, where and were trucked to Baltimore, Maryland, where they were held over in respect for the Memorial Day weekend (and Washington region holiday traffic!)

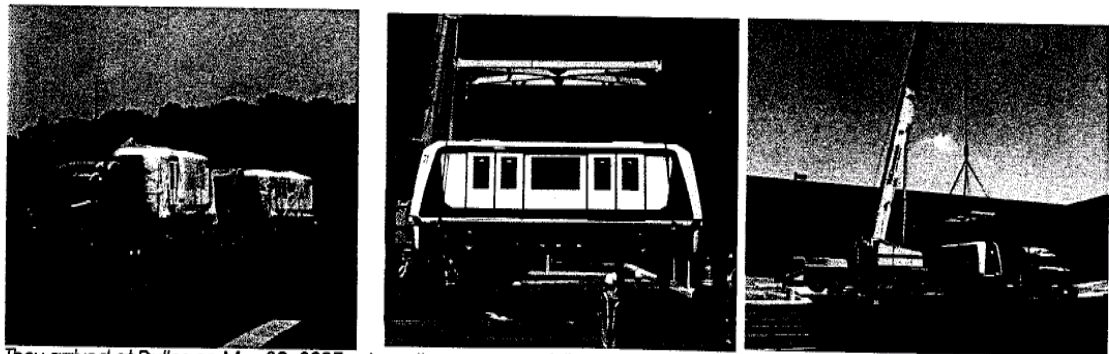

They arrived at Dulles on May 30, 2007, where they were carefully removed from the trucks and placed into the AeroTrain Vehicle Maintenance Facility where they are being prepared for system testing in the near future..

Airport Traffic Control Tower



Constructs a new 325 foot high Airport Traffic Control Tower and Base Building. The new ATCT will go into service July 2007.

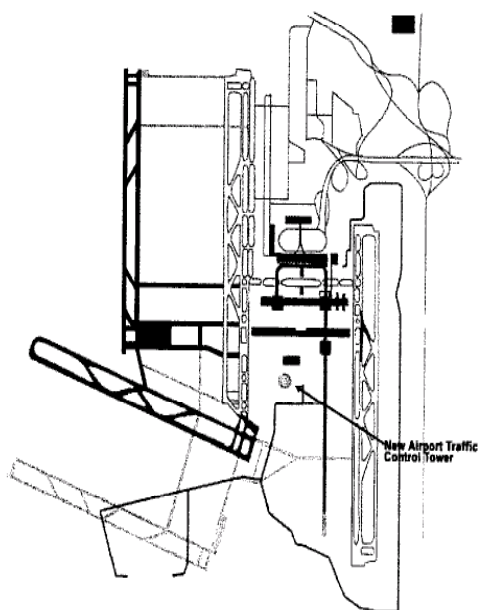

Notice to Proceed: January 2004
Substantial Completion: February 2006
Designer: Jacobs Facilities Inc.
Contractor: Smoot Construction

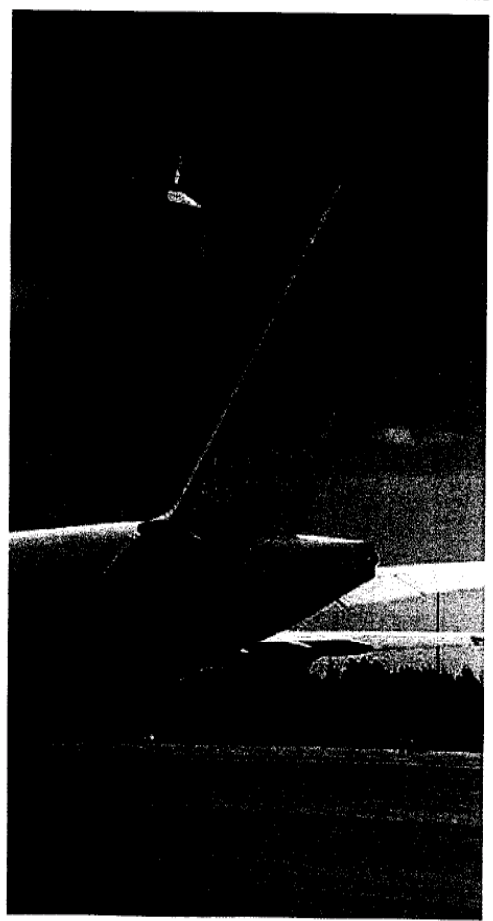
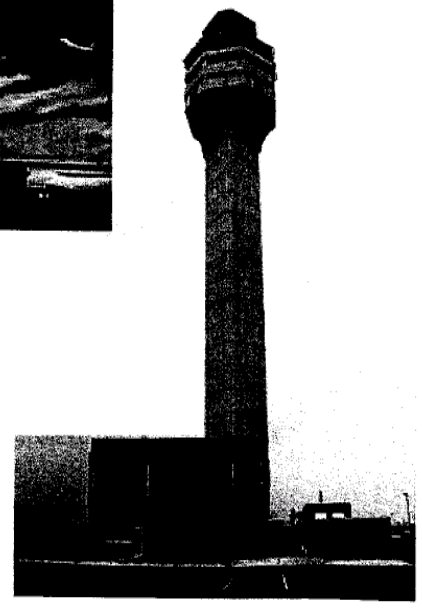
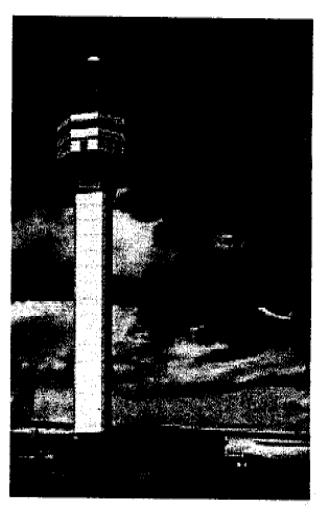
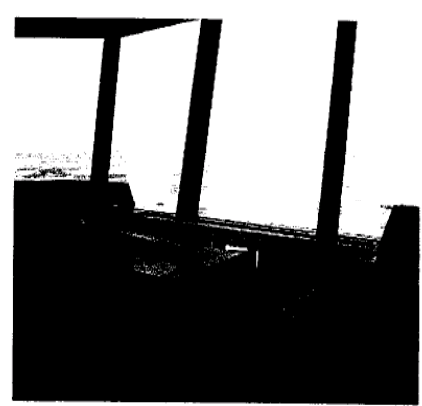

East AeroTrain Tunnels & Stations

The Concourse B Station will serve passengers at the A and B Midfield Concourses. The East Tunnel will provide passenger service between the Main Terminal, Concourse A/B and Tier 2 and temporarily to Concourse C/D). The tunnel will then extend another approximately 6,000 feet south to the Vehicle Maintenance Facility.

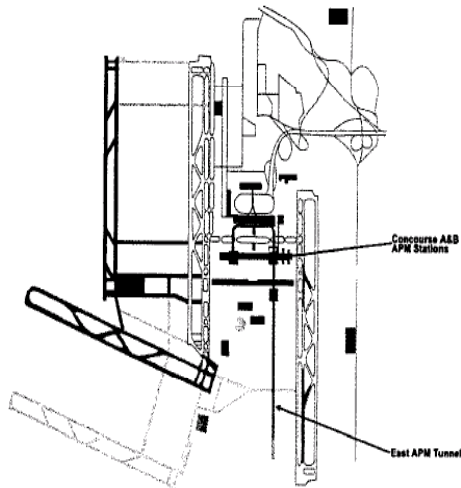

Notice to Proceed: October 2004
 Substantial Completion: September 2008
 Designer: HNTB
 Contractor: Atkinson/Clark/Shea

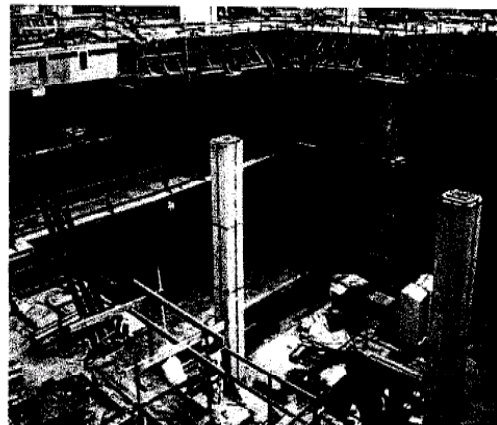
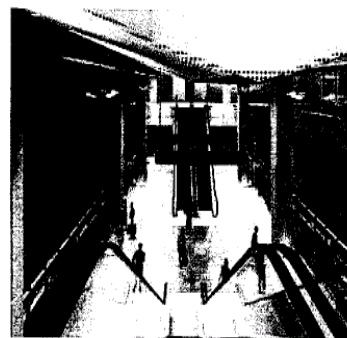
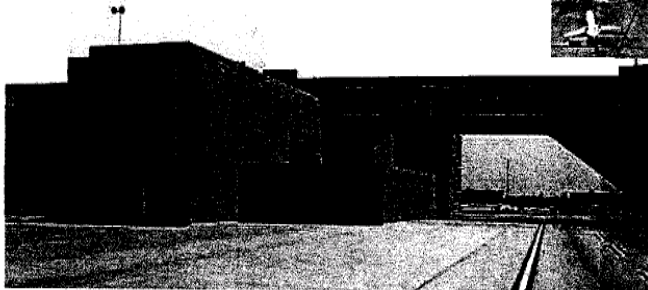
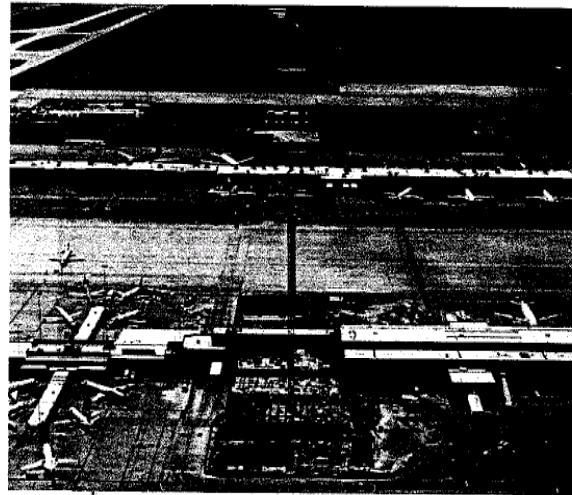

Fourth Runway



The project consists of installation of erosion and sedimentation control materials, airfield/roadway pavements, utilities, marking/signage, permanent AOA fence, NAVAIDS, and biological treatment units.

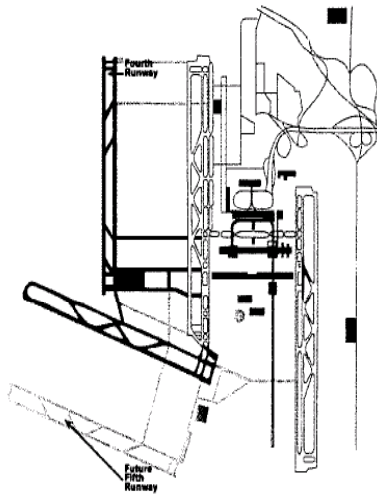

Notice to Proceed:	July 2006
Runway Opens:	November 2008
Substantial Completion:	April 2009
Designer:	Carter & Burgess, Inc.
Contractor:	Lane Construction Corporation

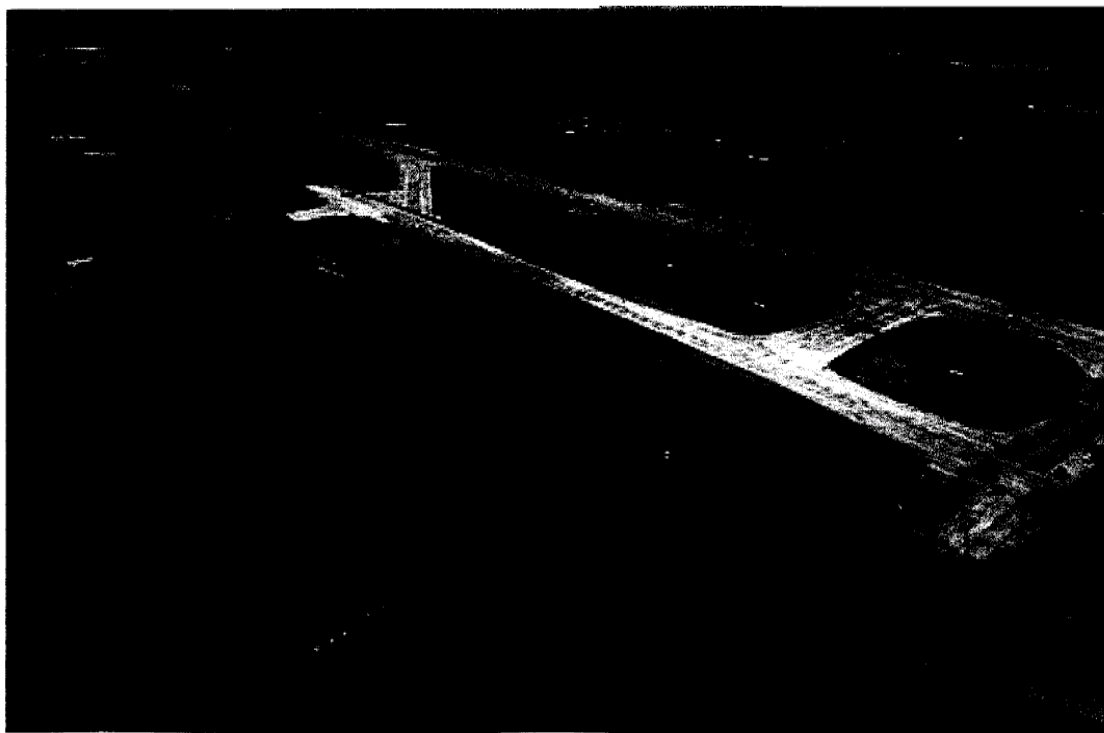
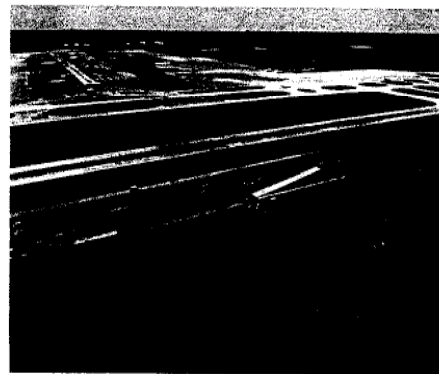

Concourse B 12-Gate Expansion and West AeroTrain Station



The West 12-gate expansion includes construction of a concourse and supporting space for domestic flights, a 60,000 sq. ft. basement with a vehicular access ramp and 11,000 sq. ft. mezzanine club level. The AeroTrain station includes below-grade concrete construction, steel superstructure and station fit out.

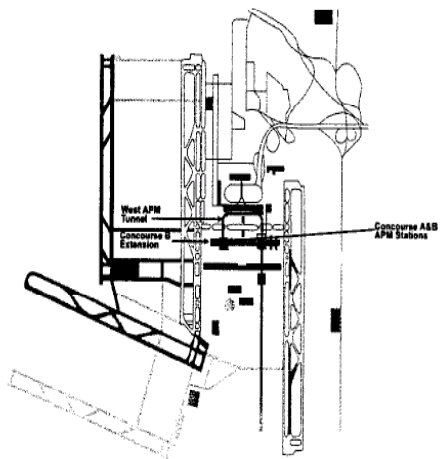

Notice to Proceed:	September 2005
12-Gate Opens:	December 2007
Substantial Completion:	August 2008
Designer:	Hellmuth, Obata & Kassabaum
Contractor:	Centex-Continental

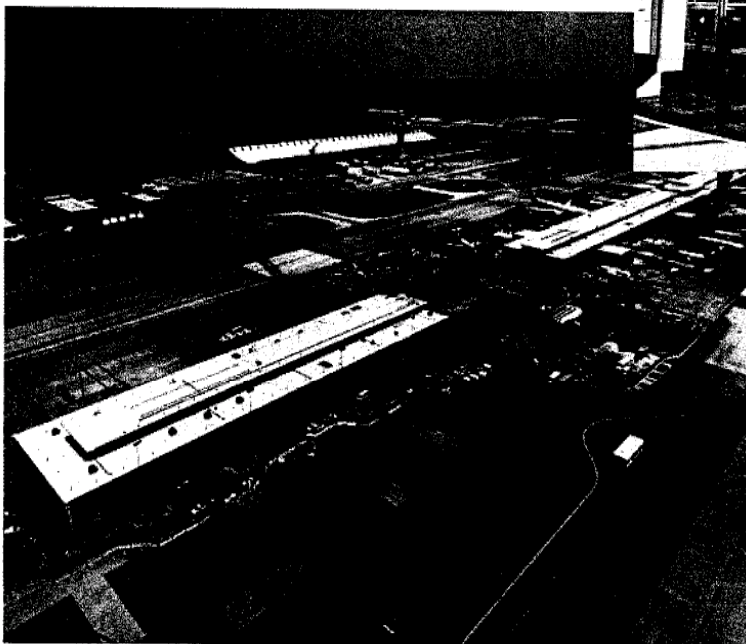
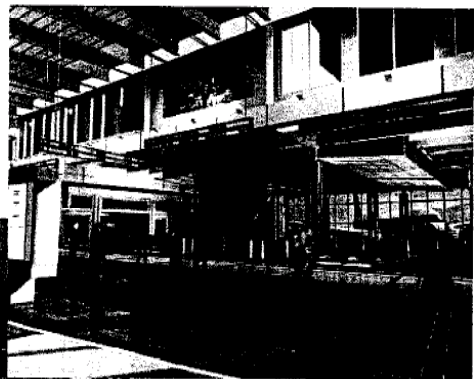

International Arrivals Building Expansion (Enabling Project)



Begins relocation of facilities to make way for 204,000 square foot expansion of the International Arrivals Building.

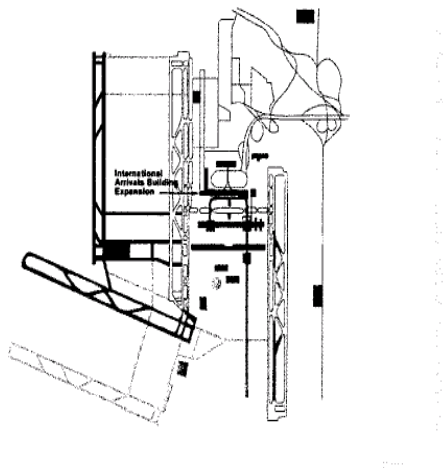

Notice to Proceed: May 2007
Substantial Completion: January 2008
Designer: Giuliani Associates Architects
Contractor: Eagle Contracting

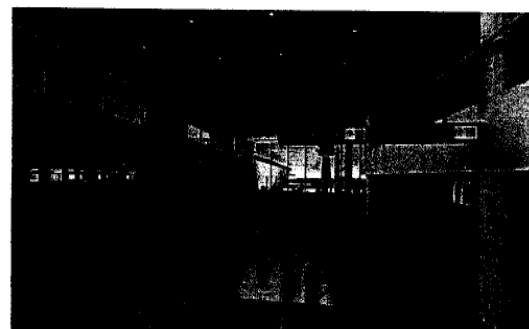
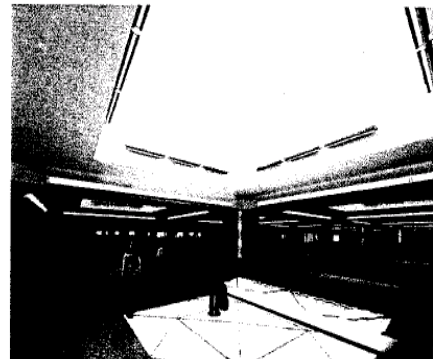
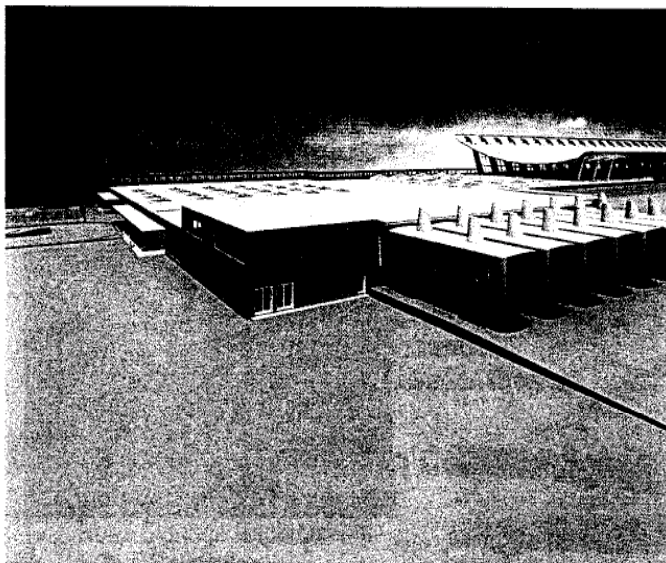
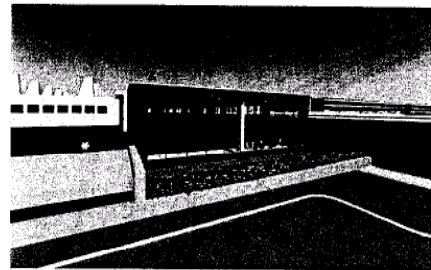

Main Terminal AeroTrain Station

Constructs a below-grade, 4-level Automated People Mover Station and Security Mezzanine along the south face of the Main Terminal complex.

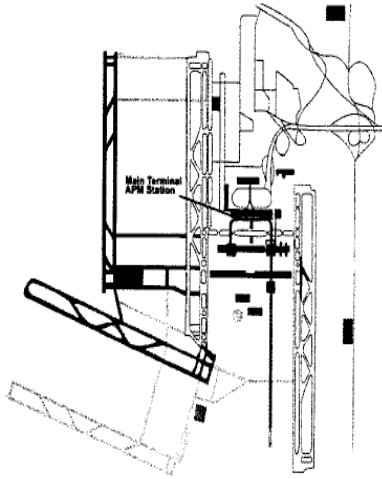

Notice to Proceed: October 2002
 Substantial Completion: January 2009
 Designer: Skidmore, Owings and Merrill
 Contractor: Turner Construction Company

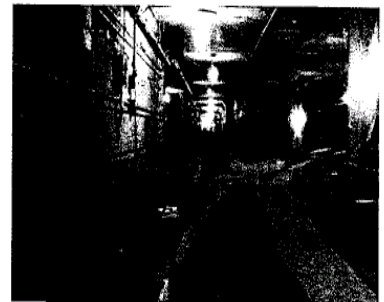
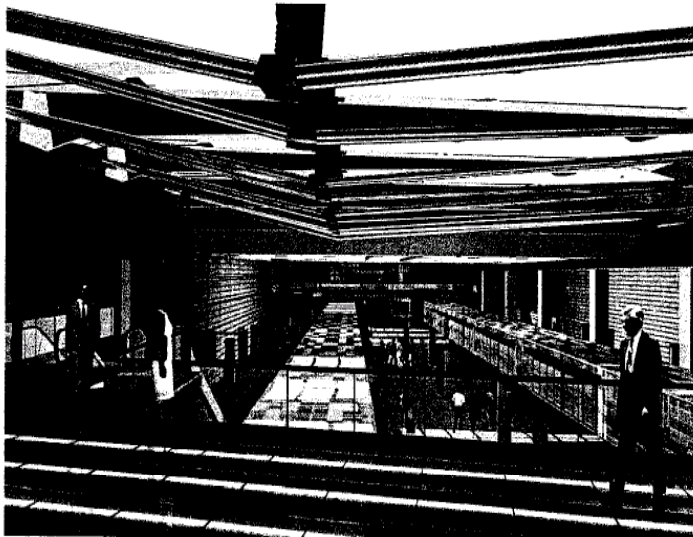
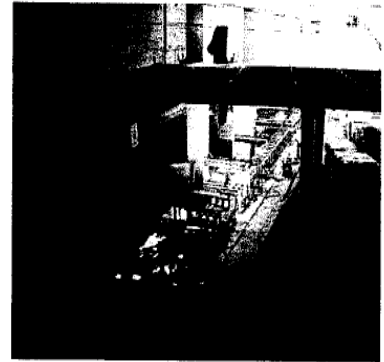
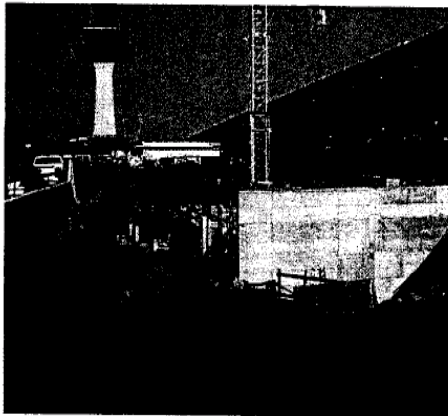
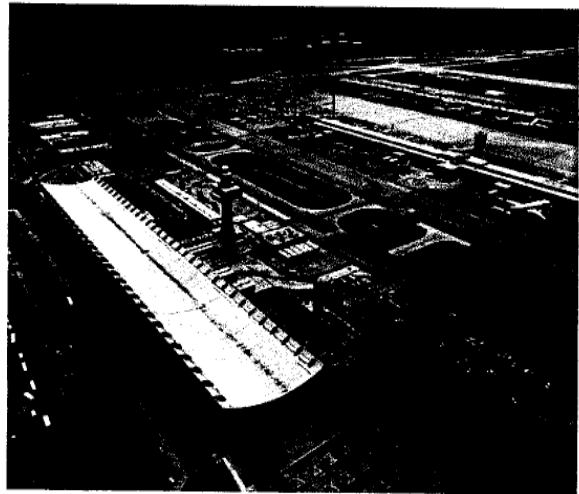

Future Projects



Major Projects Currently in Planning

- Consolidated Rental Car Facility
- Main Terminal Curb Expansion & AVI
- Gate 313 Sewer Connection
- North Area Utilities Extension
- Dulles Police Station

Major Projects Currently in Design

- Runway 1C/19C Midfield Connector Tunnel
- North Area Roads – South Section Phase III
- North Area Airside Access Road
- Supervisory Control and Data Acquisition (SCADA) System Upgrade
- 800Mhz Supplemental Radiating System Head End
- International Arrivals Building (IAB) Expansion
- IAB Enabling Projects
- Main Terminal Temporary Security Screening (East and West)
- Main Terminal Final Mezzanine Security Screening
- SUB Domestic Water Storage Tank & Pump House
- Inline Baggage Basement (South and East)
- South Baggage Basement EDS In-Line
- East Baggage Basement Expansion
- East Baggage Basement Re-Check Tunnel Transitions Package
- Deicing and Support Facilities
- West APM Tunnels – Tier 1 to Tier 2
- IAD Crash Network System
- Fire Alarm Network Architecture Survey Design
- Conveyance Monitoring System Expansion Phase 2
- Permanent Sign System Rehabilitation
- Airfield Pavement Panel Rehabilitation Program

Major Projects Currently in Construction Procurement

- Road Signage Replacement
- NOAA Relocation
- Tier 2 Concourse C Connector
- Rehabilitate Taxiway B Airfield Shoulders
- Taxiway K2 Widening & Reconstruction of Hold Apron 19L



METROPOLITAN WASHINGTON
AIRPORTS AUTHORITY

六、備註

(一) 會議期間 (96.6.10~96.6.13) 照片—華盛頓會議中心 (Washington Convention Center)



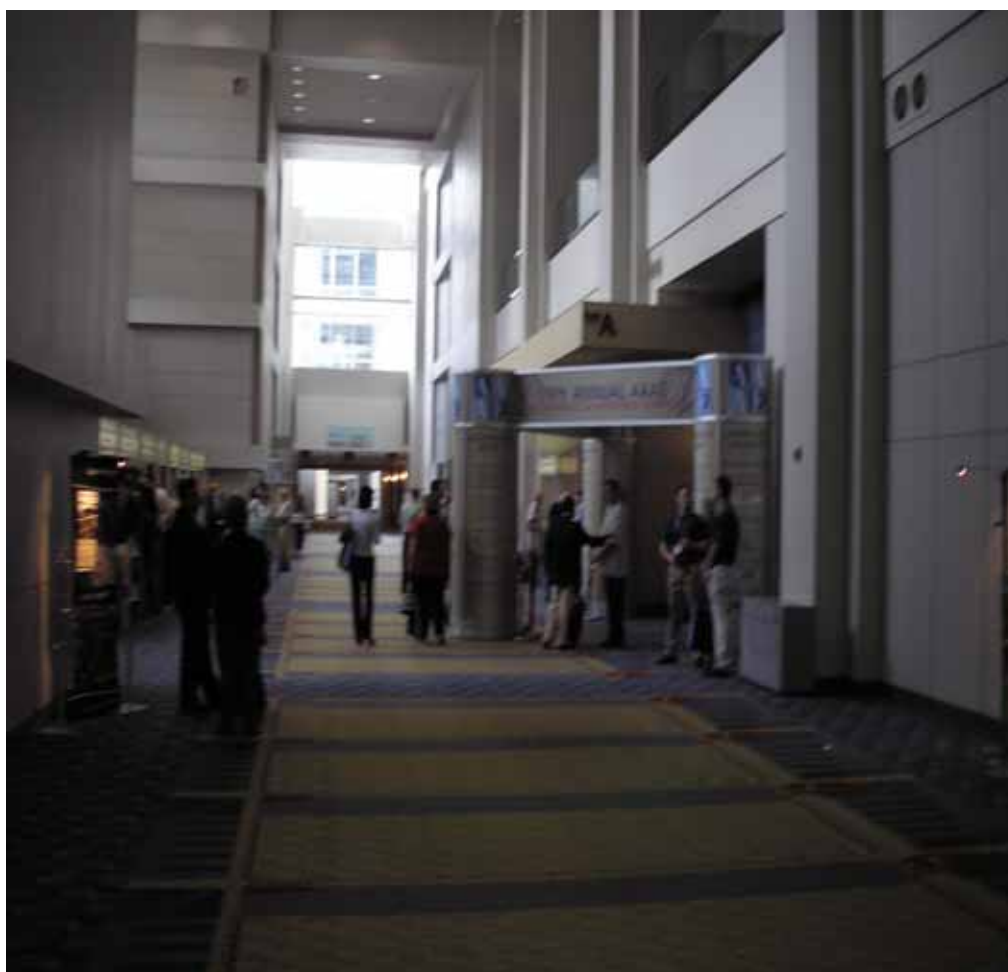

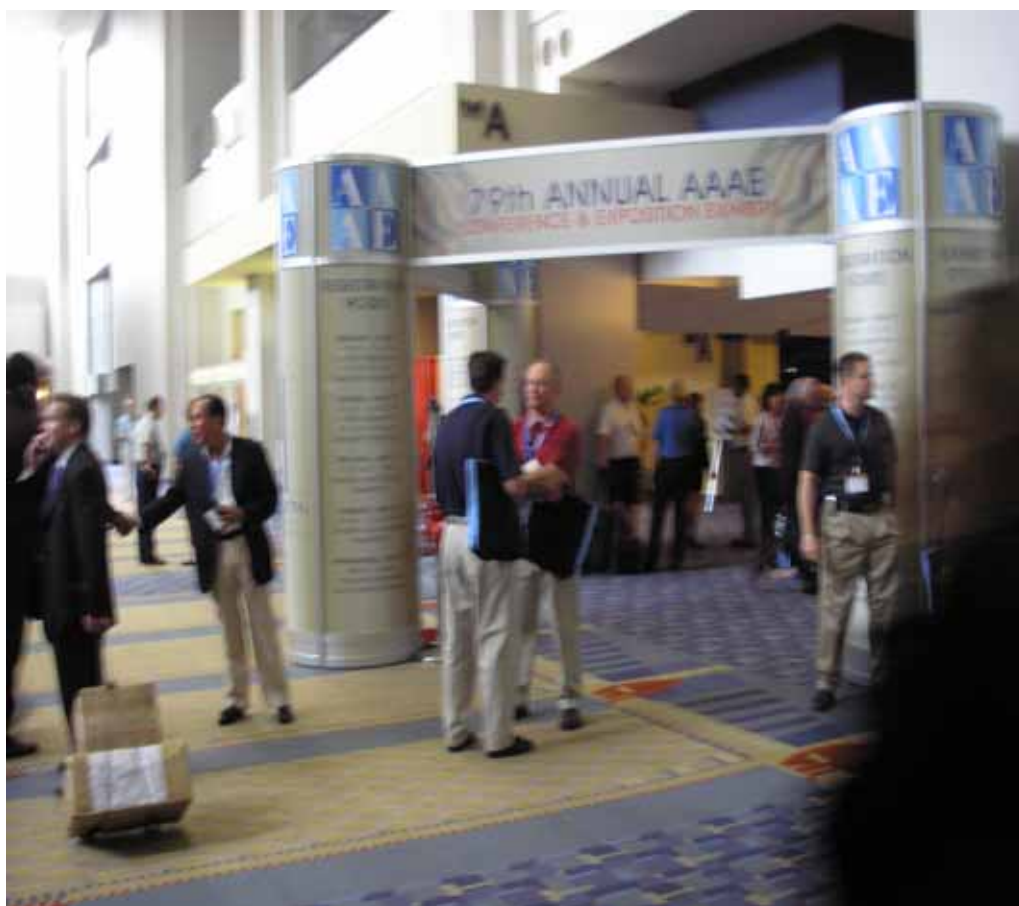

君悅飯店 (Grand Hyatt Washington)





(二) 參訪華盛頓杜勒斯國際機場 (Washington Dulles International Airport) 照片









