

行政院及所屬各機關出國報告

(出國類別：其 他)

第五屆歐洲大學協會會議

參訪報告

出國人：	教育部前部長	郭為藩
	國立政治大學校長	鄭瑞城
	淡江大學歐研所所長	邱大環
	教育部常務次長	呂木琳
	教育部高教司副司長	何卓飛

中華民國九十二年十一月十一日

CO/CO9300170

系統識別號:C09300170

公務出國報告提要

頁數: 27 含附件: 否

報告名稱:

第五屆歐洲大學協會會議參訪報告

主辦機關:

教育部

聯絡人/電話:

馬淑珍/23565907

出國人員:

呂木琳 教育部 常務次長室 常務次長
郭為藩 教育部
鄭瑞城 教育部 國立政治大學 校長
邱大環 教育部 私立淡江大學歐洲研究所 所長
何卓飛 教育部 高教司 副司長

出國類別: 其他

出國地區: 羅馬尼亞

出國期間: 民國 92 年 10 月 19 日 - 民國 92 年 10 月 28 日

報告日期: 民國 92 年 11 月 11 日

分類號/目: C0/綜合(文教類) C0/綜合(文教類)

關鍵詞: 歐洲大學協會、高等教育、雙聯學位、聯合學位

內容摘要:

為增進與歐洲各大學之相互了解，擴增我國之國際能見度，促進我大學與歐洲大學之交流與更進一步之關係，以及了解歐洲國家各大學雙聯學位之推動情形，作為國內各大學推動雙聯學位之參考，教育部特請前部長郭為藩、公、私立大學校院協(進)會各派一位校長及本部相關主管組團參加第五屆歐洲大學協會會議。本次會議除了宣導我國高等教育概況外，並具有重要的象徵性意義及達成多項積極的效益。1.歐洲大學協會在歐洲是個相當具有影響力的機構團體，獲邀參加，具有深切的意義2.深入瞭解歐洲高等教育發展的趨勢與動態，並獲悉其高教改革的經驗，可供國內推動高等教育改革的參考3.首度參加在羅馬尼亞舉辦如此大型的國際學術會議，具有學術破冰交流之意義4.行前交換意見，兩協會皆準備資料，介紹我國現況及高教發展情形，會中積極接觸，拓廣了國內大學與歐洲學術交流的管道與範圍。5.會議之效能，充分顯示歐洲大學自主與責任運作之機制，足提供我國各大學協會未來運作之參考範式6.建議非屬於歐洲大學協會會員國之大學亦應給予機會參與此歐洲大學joint degree之計畫而獲得歐洲大學協會善意的回應7.邀訪歐洲大學協會主管及著名大學校長來台訪問欣然答應，促使大學國際化實質的進展8.奧地利學術流中心提供之獎學金已取消給予特定國家學生，拜會後則表示，對於非歐盟國家之留學生可以再研議給予特殊的考量9.奧國一些大學學術主管認為，我國具有特色的學程該國學生亦有興趣，諸如EMBA結合科學實驗園區實習的課程，或結合本土文化語言學習的學程等，建議我國有關已具有優勢特色的大學開設類此學程

則可增加該國學生來台留學之意願，可作為我舉辦教育展及吸引外國留學生做法之參考

本文電子檔已上傳至出國報告資訊網

目 錄

照片集錦.....	1
壹、參訪緣起與目的.....	9
貳、計畫行程.....	10
參、歐洲大學協會組織、目標、運作與功能.....	11
肆、參訪紀實.....	14
伍、結論與建議.....	20
陸、附錄.....	24
一、邀請函	
二、大會手冊	
三、議程	
四、大會主席、地主國總統、地主大學校長致詞參考稿	
五、會議分組座談名錄	

第五屆歐洲大學協會會議參訪報告摘要：

為增進與歐洲各大學之相互了解，擴增我國之國際能見度，促進我大學與歐洲大學之交流與更進一步之關係，以及了解歐洲國家各大學雙聯學位之推動情形，作為國內各大學推動雙聯學位之參考，教育部特請前部長郭為藩、公、私立大學校院協（進）會各派一位校長及本部相關主管組團參加第五屆歐洲大學協會會議。

本次會議除了宣導我國高等教育概況外，並具有重要的象徵性意義及達成多項積極的效益。

1. 歐洲大學協會在歐洲是個相當具有影響力的機構團體，獲邀參加，具有深切的意義

2. 深入瞭解歐洲高等教育發展的趨勢與動態，並獲悉其高教改革的經驗，可供國內推動高等教育改革的參考

3. 首度參加在羅馬尼亞舉辦如此大型的國際學術會議，具有學術破冰交流之意義

4. 行前交換意見，兩協會皆準備資料，介紹我國現況及高教發展情形，會中積極接觸，拓廣了國內大學與歐洲學術交流的管道與範圍。

5. 會議之效能，充分顯示歐洲大學自主與責任運作之機制，足提供我國各大學協會未來運作之參考範式

6. 建議非屬於歐洲大學協會會員國之大學亦應給予機會參與此歐洲大學 joint degree之計畫而獲得歐洲大學協會善意的回應

7. 邀訪歐洲大學協會主管及著名大學校長來台訪問欣然答應，促使大學國際化實質的進展

8. 奧地利學術流中心提供之獎學金已取消給予特定國家學生，拜會後則表示，對於非歐盟國家之留學生可以再研議給予特殊的考量

9. 奧國一些大學學術主管認為，我國具有特色的學程該國學生亦有興趣，諸如EMBA結合科學實驗園區實習的課程，或結合本土文化語言學習的學程等，建議我國有關已具有優勢特色的大學開設類此學程則可增加該國學生來台留學之意願，可作為我舉辦教育展及吸引外國留學生做法之參考

本次參訪之建議

1. 為擴展我國國際能見度，建議應視EUA會議主題，積極主動參與

2. EUA會員多達640以上，宜鼓勵國內各大學積極參與學術交流，以促進國際化

3. EUA與歐洲教育部長會議之間互動良好，且運作效能極佳，對於歐洲教育之融合與水準之提昇有顯著之成效，足資借鏡

4. EUA對於Joint Degree之推動，採取一系列計畫方式推動，除了試辦檢討與研究外，如何取得共識的做法，頗值效法

5. EUA以歐洲面向為主來推動建立歐洲高等教育之“歐洲品牌”學位，以品質保證且有別於美加之學位，確值國內大學省思

關鍵字：歐洲大學協會、高等教育、雙聯學制、聯合學位



圖一：參觀奧地利皇宮



圖二：參觀維也納森林古堡



圖三 拜訪奧地利國際學術中心



圖四 與奧地利學術界餐會（一）



圖五 與奧地利學術界餐會（二）



圖六 EUA 報到現場

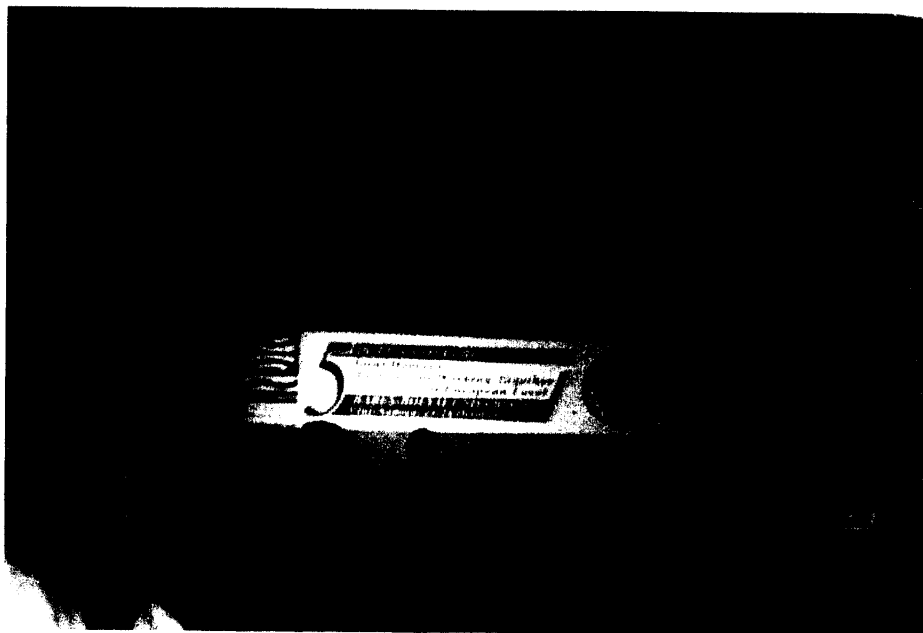

圖七 EUA 大會開始情形



圖八 EUA 大會主席致詞

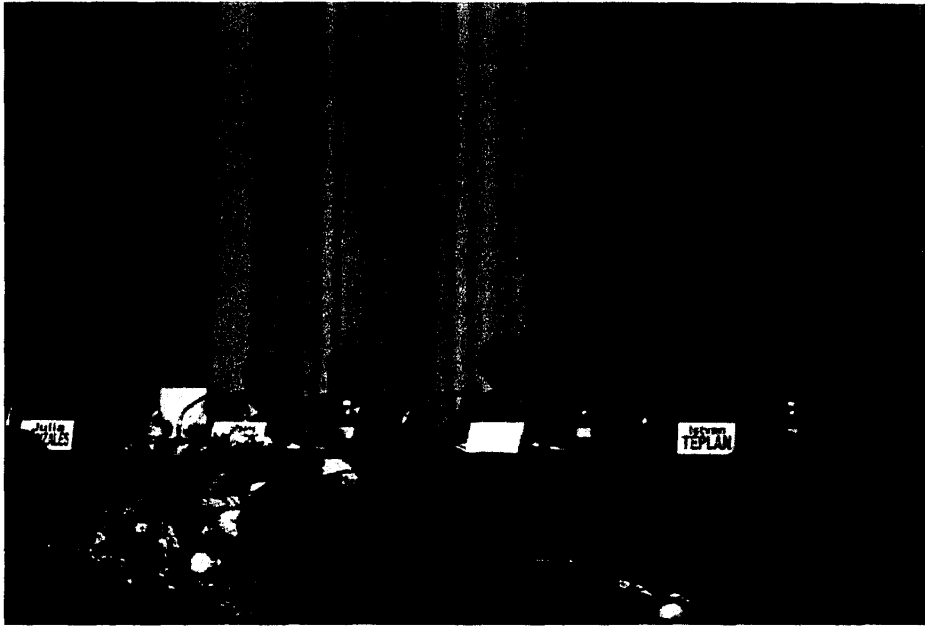

圖九 EUA 大會主席團



圖十 EUA 會場茶敘聯誼



圖十一 研討會會場



圖十二 EUA 會場餐敘聯誼



圖十三 拜會 BABES-BOLYAI UNIVERSITY 大學校長合影



圖十四 次長與 BABES-BOLYAI UNIVERSITY 大學校長合影



圖十五 BABES-BOLYAI UNIVERSITY 大學校園校景



圖十六 參觀 RAMETI CONVENT

第五屆歐洲大學協會會議參訪報告

壹、參訪緣起與目的

受到全球化、民主化、多元化的發展，以及我國加入世界貿易組織（WTO）的重大影響，國內大專校院面臨國外大學競爭壓力與教育市場開放的衝擊日益增加。為提昇國內各大專院校競爭力及促進與國際接軌，教育部訂定提昇國際競爭力計畫，包括鼓勵設置國際留學生學院、建置雙語環境與配套措施、提昇學生外語能力、開設外語學程及建立雙聯學制等積極推動之。

歐洲大學協會（European University Association 簡稱 EUA）訂於本（九十二）年十月二十三至二十五日於羅馬尼亞 CLUJ-NAPOCA 舉辦第五屆會議，大會主題為「Working Together—Joint Degrees」，將探討共同聯合學位之承認及各國各校實施情形，與我國目前正積極推動大學國際化—建立雙聯學制課題切合，乃請駐歐盟兼駐比利時代表處文化組聯繫 EUA 秘書處接洽我派團與會事宜，經獲 EUA 秘書處正面回應得以非會員之觀察員身分四至五名成員與會，並由 EUA 主席 Prof. Eric Froment（Ancien President, Universite Lumiere Lyon 2, 前法國里昂二大校長）具名邀請。

經決定洽請前部長郭為藩、公、私立大學校院協（進）會各

派一位校長（國立大學協會理事長國立政治大學鄭校長瑞城、私立大學協進會代表淡江大學歐洲研究所所長邱大環）及本部相關主管（呂次長木琳及高教司副司長何卓飛）組團與會。希冀經由參與本次會議達成下列目的：

- 一、 介紹我國高等教育之概況，並增進與歐洲各大學之相互了解，擴增我國之國際能見度。
- 二、 必要時邀請 EUA 相關領導人員及歐洲大學校長來台訪問，促進我大學與歐洲大學之交流與更進一步之關係。
- 三、 了解歐洲國家各大學雙聯學位之推動情形，作為國內各大學推動雙聯學位之參考，同時加強我大學與歐洲大學更密切互動之關係，以提供雙方進一步建立雙聯學位及有關學術合作之可能性。

貳、計畫行程

時間	地點	工作內容
十月十九日晚	台北一	啟程
十月二十日	維也納	訪奧地利學術交流中心主席 Univ.-Prof. Dr. Alfred Ebenbauer
十月二十一日	維也納	訪維也納音樂暨藝術大學副校長 Univ.-Prof. Dr. Alfred Ebenbauer

十月二十二日	維也納—羅馬尼亞	轉機行程
十月二十三日	BABES-BOLYAI UNIVERSITY	報到與聯誼
十月二十四日	BABES-BOLYAI UNIVERSITY	出席會議
十月二十五日	BABES-BOLYAI UNIVERSITY	出席會議
十月二十六日	羅馬尼亞	訪 BABES-BOLYAI UNIVERSITY 校長
十月二十七日	羅馬尼亞--維也納—台北	返程
十月二十八日	台北	返國

參、歐洲大學協會組織、目標、運作與功能

(一) 成立時間：二〇〇一年三月三十一日

(二) 組成性質：歐洲大學與校長之代表組織，現任主席為 Prof.

Eric FROMENT, Ancien President, Universite Lumiere Lyon

2. 協會設有秘書處，其辦公室分設在日內瓦與布魯塞爾兩地。

(三) 成立宗旨：積極支持與輔導成員有關之教學品質與學術研究發展及提昇對社會之貢獻，以及推廣歐洲高等教育與研究一致性制度的發展。

(四) 目標：

1. 推廣及捍衛大學的價值與大學自主權。
2. 推廣歐洲高等教育與研究一致性制度的發展。

3. 支持與指導會員學校高等教育與研究的發展。
4. 提供會員資訊與服務。
5. 代表高等教育與研究，左右各國與歐盟的政策決定。
6. 鼓勵會員間合作。
7. 建立歐洲與全世界高等教育與研究的合作夥伴關係。

(五) 發展策略：

1. 歐洲高等教育與研究的認同乃基於高等教育機構間共享的價值觀，就如教育是一項社會公益及研究室學習之基礎。
2. 歐洲高等教育結構的相容性係藉由共同的規範來加強高等教育在知識社會的創新與傳播角色。
3. 歐洲高等教育與研究區域的整合有利於提昇歐洲高等教育對歐洲及全世界的吸引力。

(六) 任務與功能：

1. 歐洲化高等教育研究—推廣波隆那宣言 (Bologna Declaration) 之目標，創造歐洲學歷與文憑全歐洲認可、探究“歐洲博士”的可能性、學術交流特別是增加教師交流的誘因、並進一步追求全球的相容性。
2. 提昇歐洲大學水準—推廣歐洲高等教育的整合性即使之透明化，特訂定品質保證、管理發展、新科技的使用、及大學

與社區之對話等策略，以支持其大學組織之發展。

3. 代表歐洲高等教育：即代表歐洲高等教育機構與國際合作夥伴進行遊說，強化與歐盟、歐洲議會、各國政府及重要教育與研究機構發展密切合作關係；並拓展與世界各區域或非會員國的合作關係。

(七) 運作方式：

1. 組織架構：分為會員大會(the General Assembly)、理事會(the Council)、管理委員會(the Board)與輪值主席。
2. 會員大會每年開會一次，為協會最高管理單位，有選舉輪值主席與管理委員會、評估與修訂協會憲章、核准新會員入會或取消會員資格、核可年度經費與預算、決定協會策略方針等。
3. 理事會由主席、管理委員會與集體正式會員的主席等組成，每年開會二次。主要功能為代表協會發言、發展政策走向、履行會員大會決議等。
4. 管理委員會包括主席與八位曾任或現任大學校長者組成，每個國家最多一位。每年開會三次，負責協會政策的實施及計畫活動與協會的管理。
5. 其他任何與歐盟政策及計畫直接有關之事務，由理事會設立

之工作小組負責進行相關業務。

肆、參訪紀實

一、會議內容摘述：EUA 推動之 Joint Degrees

(一) ECTS(European Credit Transfer System)

1. 180 credits Bachelor + 120 credits Master

(3+2) [two-tier programme]

2. 240 credits Bachelor-30 to 60 may be waived + 90 to 120
credits Master

(4+1) [two-tier programme]

3. 300 credits Master (integrated programme)

(5-6) [one-tier programme]

(二) 類型一

1. 數校合頒 (joint degrees與two degrees)

2. 各校分別頒 (joint degrees與two degrees)

3. 歐洲碩士, 博士學位(剛起步推動)

4. Diploma Supplement

(三) 主要領域一

economics/business and engineering

,law and management)

(四) 功能與效益

1. 多語言的學習
2. 多元文化的認識與尊重
3. 跨國職場之競爭優勢
4. 完整知識之獲得（如國際法）
5. 跨國合作關係之建立
6. 創造歐洲學歷與文憑全歐洲認可
7. 整體品質之提昇
8. 增加教師與學生流動的誘因

（五）Curricula與Joint Degree問題

1. 學制銜接問題：各國學制差異性
2. 文憑品質認證與評鑑問題（名校不參與）
3. 收費與預算問題：外籍生照顧、開課成本，以及收費標準
4. 課程規劃問題：課程特色與本位課程
5. 法規問題：各國相關法規扞格與競合
6. 機構獲益問題：機構辦理聯合學位有何效益
7. 語言問題：二個以上歐洲語或第二外語，授課語言不完善
8. 職員(staff)問題：如負擔加重

（六）其他相關事宜

1. 評鑑與品質保證。

2. 建立歐洲高等教育機構之“歐洲品牌” 提昇歐洲高等教育對歐洲及全世界的吸引力。
3. 拓展與世界各區域或非會員國的合作關係。

二、拜會

(一) 奧地利學術交流中心主席 Univ.-Prof. Dr. Alfred Ebenbauer

1. 中心性質之說明：

「奧地利學術交流中心」為一國際教育與科學合作之辦事處，一九六一年由「奧地利校長會議」所成立，目的在於協助外國學生在奧地利停留期間之相關事務。

現今奧地利學術交流中心為奧地利最大的公益性國際學生與學術交流辦事處，主要任務如下：

- (1) 進行聯邦教育科學文化部及聯邦外交部的獎學金計畫，負責獎學金生及客座教授在奧地利之照管及返國之後的聯繫。
- (2) 歐洲教育與交流計畫 SOKRATES 及 LEONARDO DA VINCI 之奧地利國家負責單位。
- (3) 負責歐洲聯盟各種第三國計畫。
- (4) 負責「奧地利-斯洛伐克」「奧地利-捷克」「奧地利-匈牙利」行動計畫之業務。
- (5) 負責「科學技術協議」。
- (6) 經營維也納大學、格拉茲大學及里歐本大學的先修班。
- (7) 負責奧地利作為高等教育據點之行銷活動。

- (8) 提供外國學生與客座教授諮詢。
- (9) 大學正式生退還學費業務。
- (10) 有關促進學術交流之利益遊說。
- (11) 與其它國際(交換)機關之聯繫與合作。
- (12) 出租外國學生與客座教授住宅。

2. 會談之共識

(1) 奧地利聯邦教科文部已決定取消以往與各國簽訂執行之雙邊交換獎學金政策，改以公佈各類獎學金，供有意赴奧地利留學或研究之外國學生與學者個別直接申請，該學術合作協定於二〇〇三年九月三十一日終止；自二〇〇四／二〇〇五學年起，奧國政府不再提供台灣學生獎學金，惟我方仍續提供每年二名獎學金供奧國學子赴台就讀。

(2) 雖雙方獎學金交換未能繼續進行，惟 Ebenbauer 稱對於非歐盟國家之留學生可以再研議給予特殊的考量。未來亦可朝向雙邊科學技術合作，努力促成雙方教師或學者互換。

(二) 維也納音樂暨藝術大學副校長 Univ.-Prof. Dr. Wolfgang

Klos

1. 會談說明

(1) 1998 年十月一日起聯邦藝術大學組織法的施行使維也納國立音樂學院與其他藝術學院正式升格為大學

- (2) 學生：3300 名學生，外國學生約佔 40%--50%間。200 名學生低於 16 歲。
- (3) 教師：約 1000 名。
- (4) 教育目標：培養、訓練學生未來擔任教師。
- (5) 畢業：50—60%畢業率。文憑分為二類，一類為 certificate (證書)，一類為授予學位文憑 (近三年—包括學士、碩士、博士)。畢業生就業情況佳。
- (6) 學生入學：無年齡限制，但較喜歡 17—25 歲，以面試並派教師赴國外甄選，錄取率低。如小提琴錄取率僅 10%。
- (7) 外籍生：曾經有多名台灣師大學生留學。東方學生大都主修鋼琴，弦樂其次，管樂較少。
- (8) joint degree：配合 Erasmos 計畫與歐洲各大學交換學生，約有 50—80 名學生參與。
- (9) 交響樂團：類職業樂團，赴歐各地演出，團員 100 名，部分學生未畢業即入樂團而放棄學業。
- (10) 學校財務：主要由政府補助，但明年度將較今年度補助少 20%，可能需要自籌部分經費。
- (11) 其他國際交流：與日本、美國有合作計劃，如與邁

阿密大學及 Osaka 大學有師生交換，但並無意大幅擴張。

2. 共識

願意明年春後接受我國大學協會或公、私立大學之邀請來台訪問或進一步座談交流（擬請淡江大學邀請）。

（三）BABES-BOLYAI UNIVERSITY 校長（曾任該國教育部長）

1. 會談說明

- （1）校名：係因有感於曾在該校任教之兩位科學家貢獻卓著紀念而以其名命名，BABES 係匈牙利人為著名之藥理學家，但娶該地女士後並於該校任教。BOLYAI 則在當地出生之數學家，且精通九國語言。
- （2）大學地位：係該國首屈一指之國立大學，有如我國之台大。
- （3）規模：學生約 44,000 人，二十學院（faculties）。
- （4）學生結構：碩士生約 1,900 人，博士生約 2,900 人，遠距教育生約 2,900 人，短期生（short time students）約 3,900 人，長期生（long time students）約 26,000 人。男性佔 32.27%，女性為 67.73%。
- （5）特色：多種族（羅馬尼亞、匈牙利、日爾曼族），故須

以多種語系教學，強調多元文化學習。

(6) 學費：年約 500 美金。

(7) 學校財務：困難，今年預算為 1,057,648,909,000 羅幣，約十億五千七百六十萬台幣。

(8) 我團員報名註冊時，因中共對我參與名稱有意見而致稍有延誤特予致意，不避諱與我國之學術交流。

2. 共識

願意明年春後接受我國政府之邀請來台訪問或進行進一步之座談交流。

伍、結論與建議

一、結論

出席本次會議除了宣導我國高等教育概況外，並具有重要的象徵性意義及達成多項積極的效益。

(一) 歐洲大學協會會員國，會員包括歐洲六百四十餘個大學及高等教育機構，該協會具有執行歷次歐洲教育部長會議宣言及會議決定的功能，主要在促進歐洲高等教育的融合與共同努力的目標，及提昇歐洲高教機構的品質與水準。因此在歐洲是個相當具有影響力的機構團體。我國能獲邀參加，具有深切的意義。(最初受理報名時僅美國及我國受邀參加)

(二) 藉著參與歐洲大學協會會議可深入瞭解歐洲高等教育發展的趨勢與動態。並獲悉其高教改革的經驗，俾供國內推動高等教育改革的參考。

(三) 過去我國高教學術交流與美、加、日等國較為頻繁，對於歐洲則顯然較少交流互動。本次會議歐洲會員參與的國家達三十四個，含我國與美國則為三十六國。參與的大學與高等教育機構達一百七十一個，出席人員近三百人。我國首度參加在羅馬尼亞舉行如此大型的國際學術會議，具有學術破冰之意義，更拓廣了國內各大學與歐洲學術交流的管道與範圍。

(四) 出席此次會議者多數為大學校長、副校長，部分為高教行政機關之主管官員，以及歐洲大學協會之主管。會議主題明確全數人員幾乎全程參與，討論熱烈，且所得具體之結論將提供歐洲教育部長會議決策之參考依據。會議之效能，得充分顯示歐洲大學自主與責任運作之機制，足提供我國各大學協會未來運作之參考範式。

(五) 由此次會議得知歐洲大學協會所積極推動的『joint degree』，係有一系列研究及完整的配套做法。例如：從各級 joint degree 之課程探討各高教機構的發展策略；對於博士層級的 joint degree 工作群的特殊挑戰；以及在一個歐洲大學協會所簽訂的 joint Master degree 計畫各機構的回應與檢討。而最為吸引人的議題，則為

以歐洲面向為特色，以邁向建立其高等教育機構的「歐洲品牌」之學位。會中呂次長除了提供我國以設立國際學生學院以英語授課，以解決修跨國學位課程學生的語言問題外，並建議非屬於歐洲大學協會會員國之大學亦應給予機會參與此歐洲大學 joint degree 之計畫而獲得歐洲大學協會善意的回應，於結論中納入將提協會研議招收非會員國之學生。但亦可發現的另一現象是：歐洲大學名校如巴黎、牛津、劍橋、慕尼黑、魯文等大學幾乎未出席本次會議，或許此種「joint degree」對於各該大學無實質之效益性，而無法吸引各該大學之興趣吧！

(六) 本次會議建立了我國大學協會與歐洲大學協會及部分中歐、東歐大學間的良好溝通管道。本部亦鼓勵各大學與歐洲大學協會各會員加強學術交流，並將邀訪歐洲大學協會主管及著名大學校長來台訪問，促使大學國際化實質的進展。

(七) 行前交換意見，兩協會皆準備資料，介紹我國現況及高教發展情形，會中積極接觸，拓廣了國內大學與歐洲學術交流的管道與範圍。

此外，行程中並赴奧地利維也納，拜會了奧地利學術交流中心主席，維也納音樂暨藝術大學副校長，及經由我駐奧地利總代表處魏代表武煉邀請該相關學術機構與大學學術主管餐敘交流，也獲致一些理解與共識：

(一) 原本奧地利學術流中心，每年皆提供我國兩名留學生獎學金，因歐盟推動「伊拉斯莫斯宣言」的「歐洲學位」計畫，而自今年四月停止該項做法，該中心獎學金不再以特定國家或對象分配，而改以自由申請的方式辦理，但限於「歐洲學位」計畫的學生。經由拜會座談後，該中心主席表示，對於非歐盟國家之留學生可以再研議給予特殊的考量。

(二) 奧國一些大學學術主管認為，我國具有特色的學程該國學生亦有興趣，諸如提供EMBA結合科學實驗園區實習的課程，或結合本土文化語言學習的學程等，建議我國有關已具有優勢特色的大學開設類比學程則可增加該國學生來台留學之意願，可作為我舉辦教育展及吸引外國留學生做法之參考。

二、建議

(一) 為擴展我國國際能見度，建議應視EUA會議主題，積極主動參與。

(二) EUA會員多達640以上，宜鼓勵國內各大學積極參與學術交流，以促進國際化。

(三) EUA與歐洲教育部長會議之間互動良好，且運作效能極佳，對於歐洲教育之融合與水準之提昇有顯著之成效，足資借鏡。

(四) EUA對於Joint Degree之推動，採取一系列計畫方式推動，除了試辦檢討與研究外，如何取得共識的做法，頗值效法。

(五) EUA以歐洲面向為主來推動建立歐洲高等教育之“歐洲品牌”學位,以品質保證且有別於美加之學位,確值國內大學省思。

附記：

本次得順利組團並能在極短的時間內取得奧地利申根簽證及羅馬尼亞簽證,最須感謝駐奧地利總代表魏武煉先生之協助。魏總代表並協助邀請奧地利有關大學校院之校長或副校長與學術界先進與本團餐敘交流,得以建立良好之溝通管道與關係,並致最深之謝意與敬意。

六、附錄

(一) 邀請函

(二) 大會手冊

(三) 議程

(四) 大會主席、地主國總統、地主大學校長致詞稿

(五) 會議分組座談名錄

附 錄



European
University
Association
EUA

www.unige.ch/eua

Brussels, 2nd October 2003

Ministry of Education in Taiwan
Bureau of International Cultural and Educational Relations
No. 5 Chung-Shan S. Road
Taipei 100
Taiwan

For the attention of:

Dr. Lu Mu-lin, Vice Minister of Education
Dr. Ho Jow-Fei, Deputy Director General, Ministry of Education
Dr. Kuo Wei-Fan, Ex-Minister of Education
Dr. Cheng Jui-Cheng, President of National Chengchi University
Dr. Tou-Chiu Da-Rouin, Associate Professor Tankang University

Ref.: 5th EUA conference in Cluj, UNIVERSITIES WORKING TOGETHER IN EUROPE: Integrated Programmes and Joint Degrees - a hallmark of the European Higher Education Area, 23-25 October 2003.

Dear colleagues,

On behalf of the European University Association (EUA) I am pleased that you have taken up our invitation to participate in the above mentioned conference and I hereby confirm that you have been registered to attend. The conference will be hosted by *Professor Andrei Marga*, Rector of the University of Babes-Bolyai in Cluj.

We have noted your travel schedule and will arrange transportation for you upon your arrival into Cluj, to bring you from the airport to your lodgings:

Monday, 20 October	BR075 Taipei 23:00---- Amsterdam 09:55
Tuesday, 21 October	KL1377 Amsterdam 13:15 ----Budapest15:15
Wednesday, 22 October	RO-9234 Budapest 13:35----15:50 Bucharest RO-658 Bucharest 16:40--- CLUJ 19:10
Monday, 27 October	RO-347 CLUJ 09:10----Vienna 09:55 BR062 Vienna13:40---Taipei 11:30

The conference office in Cluj will contact you shortly to confirm your lodgings.

I look forward to welcoming you in Cluj.

Yours sincerely,

Eric Froment
President, EUA

EUA Brussels
Rue de la Loi 42 Wetstraat • B-1040 Brussels
Tel: +32-2 230 55 44 • Fax +32-2-230 57 51

25

EUA Geneva
10 rue du Conseil-Général • CH-1211 Genève 4
Tel: +41-22-329 26 44/22 51 • Fax +41-22-329 28 21



European
University
Association

UNIVERSITATEA
BABES-BOLYAI



5th EUA CONFERENCE

Working Together: Joint Degrees

BABES-BOLYAI UNIVERSITY
Cluj-Napoca, 24-25 October 2003

Programme

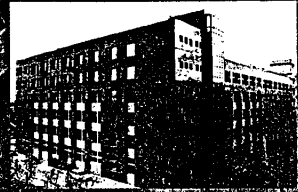
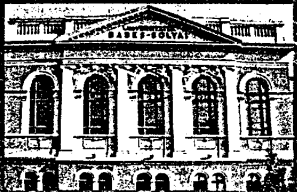

5th EUA CONFERENCE

Host:

Andrei Marga
Rector, Babeş-Bolyai University Cluj

EUA Organisation:

Lesley Wilson
EUA Secretary General

David Crosier
EUA Senior Programme Manager

Joanne Dee
EUA Conference Organiser

Local Organisation:

Cătălin Baba, Conference Organiser
Camelia Moraru, Conference Officer
Raluca Buciuman, Conference Secretary

Conference Website: [http:// eua.ubbcluj.ro/](http://eua.ubbcluj.ro/)

European University Association

Rue de la Loi 42, 1040 Bruxelles
Tel: +32 2 2305544 - Fax: +32 2
2305751
info@eua.be
<http://www.unige.ch/eua>

10, Rue du Conseil Général - CH-1211 Genève 4
Tel: +41 22 3292251 - Fax: +41 22 3292821
info@eua.unige.ch

Babeş-Bolyai University
<http://www.ubbcluj.ro/>
1, M. Kogalniceanu Street
RO-3400 Cluj-Napoca
Phone: +40 264 405300
Fax: +40 264 591906
e-mail: conference@eua.ubbcluj.ro

WENS Tour Travel Agency
10, Eroilor Boulevard
RO-3400 Cluj-Napoca
Phone: +40 264 590748, (9)
e-mail: wenstour@mail.dntcj.ro

Discussion group A – Group 1:

Joint programmes (Ba/Ma/Phd) - developing an institutional strategy

Chair: Professor Roderick FLOUD, EUA Board, Vice-Chancellor London Metropolitan University,

Rapporteur: Lewis Purser, EUA

Discussion group A – Group 2:

Joint programmes (Ba/Ma/Phd) - developing an institutional strategy

Chair: Professor Andrejs RAUHVARERS, Secretary General, Latvian Rectors' Council, Riga

Rapporteur: Ms Tish BOURKE, Manager Europe Unit, Universities UK, London

Discussion group B:

Anchoring Joint Masters in the institution - lessons from the EUA Pilot project

Chair: Dr Carmen RUIZ-RIVAS, Professor, Universidad Autonoma de Madrid, Spain

Presenter: Professor Dr Jurgen KOHLER, Former Rector, Ernst-Moritz-Arndt-Universität Greifswald, Germany

Rapporteur: Kate Geddie, EUA

Discussion group C

Particular challenges of working together at doctoral level

Chair: Dr Jan SADLAK, Director, Unesco-Cepes, Bucharest, Romania

Presenter: Ms Julia Maria GONZALEZ FERRERAS, Vice Rector for international Affairs, University of Deusto, Spain,

Rapporteur: Mr Matei LIVIU, Academic Secretary, Central European University, Budapest, Hungary

Discussion group D

Towards a European Label for higher education institutions: demonstrating the European dimension in institutional practice

Chair: Eric Froment, EUA President

Presenter: Lesley Wilson, EUA Secretary General

Rapporteur: David Crosier, EUA

INTRODUCTION

UNIVERSITIES WORKING TOGETHER IN EUROPE: Integrated Programmes and Joint Degrees - a hallmark of the European Higher Education Area

Context, Aims and Objectives

The Graz Convention of European Higher Education Institutions in May 2003 underlined the commitment of Europe's universities to the creation of the European Higher Education and Research Areas. By building on the strength of the institutions involved, integrated programmes and joint degrees were considered to be a particularly effective means of promoting the European dimension. While inter-institutional cooperation and networking has been developing rapidly over the last 15 years, the emergence of structured joint degrees with duly recognised qualifications is a new development which involves much greater reflection, and indeed commitment, on behalf of institutions than the looser inter-institutional cooperation arrangements prevalent hitherto.

It is for this reason that the European Education Ministers who are meeting in Berlin in September to decide on the next steps in the Bologna process will also be asked to take action to facilitate the recognition of such degrees, and it is for this reason that the EUA has decided to engage its member institutions in a debate on how to develop further high quality joint degrees which the TRENDS III Report identifies as an „unrealised potential“:

- As a tool for institutional development and for the strategic positioning of institutions and networks,
- as an opportunity for fostering and expanding mobility within Europe, and
- as an instrument to increase the attractiveness of the European Higher Education Area, as proposed in the ERASMUS Mundus initiative of the European Commission.

Discussions in Cluj will be based upon the experience of the Joint Master Pilot Project that EUA has been implementing with Socrates funding over the last year, as well as on preparatory work for a similar project soon to be launched at doctoral level. This reflects the growing awareness of the importance of linking the European Higher Education and Research Areas, and of the pivotal role of doctoral studies in this process.

The goal of this Conference will be to discuss the implications for institutions of making joint degrees work and thus embedding the European dimension in everyday institutional reality. The results of the Joint Master pilot project have shown that *developing and running meaningful joint degrees means not only using the different Bologna tools and instruments in a coherent and coordinated way, but also putting emphasis upon the core values of the European university discussed in Graz, namely equity and access for students; cultural and linguistic diversity; a strong quality culture; and the link between teaching and research.*

Using this example, EUA also wishes to encourage reflection and debate upon the utility/appropriateness of developing further the concept of a European label – first mentioned in Graz - which would recognise and reward the European dimension of institutional activity. One further goal of the Cluj Conference is therefore to consider what features of institutional experience should be considered for such a label, and what role EUA could play in developing such a European label.

Through discussion in plenary sessions and thematic working groups, participants will have an opportunity to exchange experience of institutional practice which can best further the development of joint degrees at all levels. A number of institutional case studies of successful innovative experience in European higher education cooperation will be presented in plenary, while participants will have the opportunity to discuss in working groups the preconditions for the successful and sustainable development and implementation of joint degrees at different levels and with different partners.

Thursday, 23 October	Friday, 24 October	Saturday, 25 October
<p>9.30 - 16.30 Joint Masters Project Coordinators' Meeting <i>Building of the Faculty of European Studies</i></p> <p>13.00 - 14.30 Lunch for the Joint Masters Meeting <i>University of Agricultural Sciences and Veterinary Medicine</i></p> <p>17.30 - 19.30 QA Alumni meeting, <i>Building of the Faculty of Chemistry and Chemical Engineering</i></p> <p>17.30 - 18.30 Discussion Group Briefing <i>Building of the Centre for International Cooperation</i></p> <p>20.30 - 22.30 Welcome Reception <i>Pyramid Restaurant</i></p>	<p>9.00 - 10.30 Opening Ceremony Plenary Session I <i>Building of the Collegium Academicum</i></p> <p>10.30 - 11.00 Coffee break <i>Pyramid Restaurant</i></p> <p>10.30 - 11.00 Press Conference <i>Faculty of European Studies</i></p> <p>11.00 - 12.00 Plenary Session II <i>Building of the Collegium Academicum</i></p> <p>12.30 - 13.00 Inauguration of the building of the Centre for International Cooperation <i>Universitas Building</i></p> <p>13.00 - 14.00 Lunch and cocktail reception <i>Centre for International Cooperation</i></p> <p>14.30 - 15.30 Plenary Session III <i>Building of the Collegium Academicum</i></p> <p>15.30 - 16.00 Coffee break <i>Pyramid Restaurant</i></p> <p>16.00 - 18.00 Working Groups Session I <i>Central Building, Faculty of Law, Faculty of European Studies</i></p> <p>20.30 - 22.30 Reception <i>Restaurant of the Victoria Hotel</i></p>	<p>9.00 - 10.30 Working Groups Session II <i>Faculty of Economics</i></p> <p>11.00 - 13.00 Plenary Session IV Conclusions and recommendations Conference Closing <i>Building of the Collegium Academicum</i></p> <p>13.30 - 16.00 Lunch <i>Restaurant of the Transylvania Hotel</i></p> <p>13.30 - 14.30 Introduction to the EUA for the Romanian member and non-member Universities <i>Central Building of the University</i></p> <p>17.00 - 19.00 Guided City Tour</p> <p>OR</p> <p>18.00 - 19.00 Opera Concert <i>National Theatre Building</i></p> <p>18.30 - 19.30 Meeting of the EUA Board with the students of the Babe-Bolyai University <i>Central Building of the University</i></p> <p>20.30 - 22.30 Dinner <i>Pyramid Restaurant</i></p>
		<p>Sunday, 26 October</p> <p>Post Conference Excursion</p> <p>Transylvania - History and Multiculturalism Route</p>

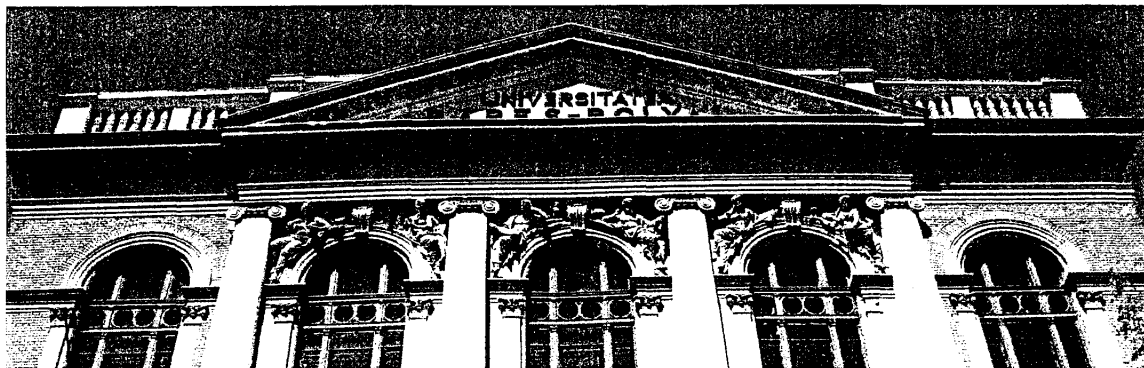

A. PRE-CONFERENCE MEETINGS

THE REGISTRATION DESK FOR
CONFERENCE PARTICIPANTS
WILL BE OPEN AS FOLLOWS:

Thursday 23 October 8.00 - 22.00
Friday 24 October 8.00 - 20.00
Saturday 25 October 8.30 - 14.00

*Location: Collegium Academicum,
5, M. Kogălniceanu Street.
Tel/Fax: 0040 264 431 795,
Email: conference@eua.ubbcluj.ro.*

Thursday, 23 October

- 8.00 - 22.00 Arrival and registration** of the participants at the Registration Desk
Location: Foyer of the Building of the Collegium Academicum, 5 Kogălniceanu Street
- 9.30 - 16.30 Joint Masters Project Coordinators' Meeting**
Location: Institute for European Research, Building of the Faculty of European Studies, 1, E. de Martonne Street
- 13.00 - 14.30 Lunch for the Joint Masters Meeting** - hosted by the Rector of the University of Agricultural Sciences and Veterinary Medicine of Cluj
Location: University of Agricultural Sciences and Veterinary Medicine, 3-5, Mănăştur Street
- 17.30 - 19.30 QA Alumni meeting** Meeting of the institutions that have been evaluated by the QA programme.
Location: Amphitheatre, Building of the Faculty of Chemistry and Chemical Engineering, 11, Arany János Street (near the Central Park)
- 17.30 - 18.30 Discussion Group Briefing** Meeting of the Chairs, facilitators and rapporteurs of the 5th EUA Conference
Location: Conference Room, Building of the Centre for International Cooperation, 7, Pandurilor Street
- 20.30 - 22.30 Welcome Reception** for all conference participants and companions, hosted by the Rector of the Babeş-Bolyai University, Andrei Marga
Location: Pyramid Restaurant (in the garden of the Collegium Academicum), 1, E. de Martonne Street

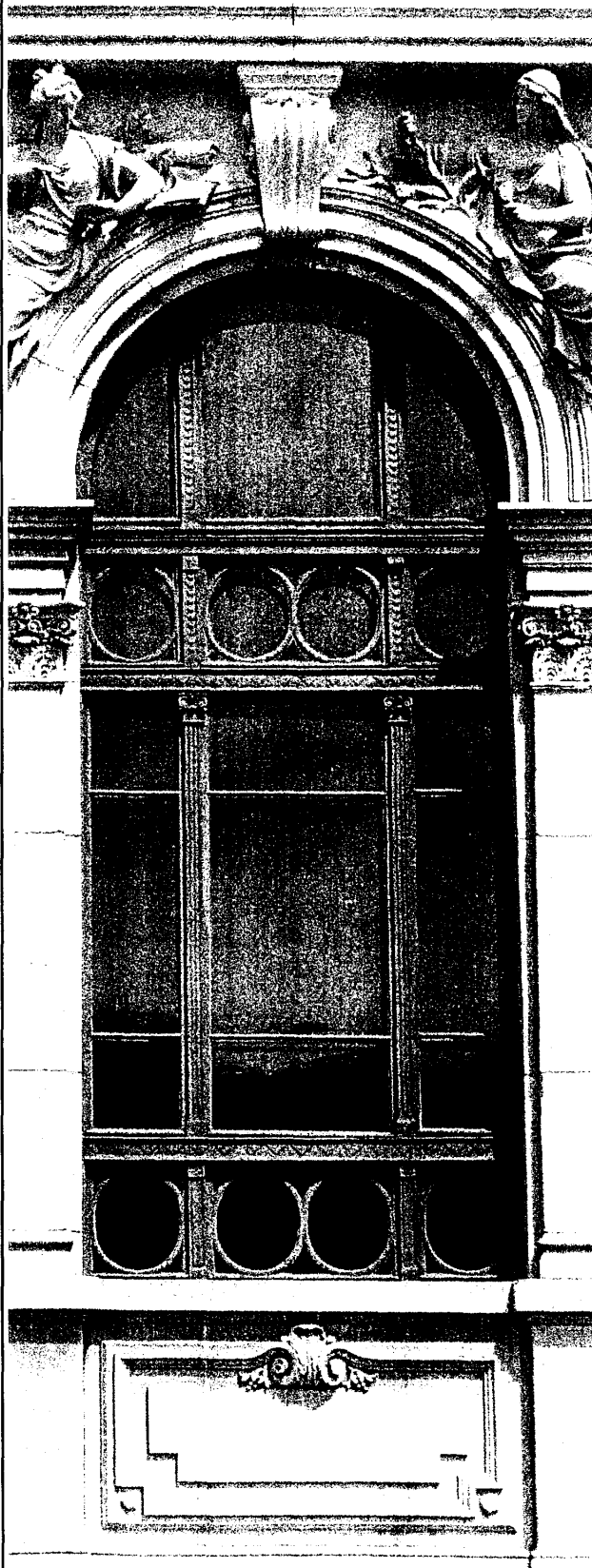

B. 5th EUA CONFERENCE PROGRAMME

Friday, 24 October

All Plenary sessions on Friday and Saturday will be held at Auditorium Maximum, Building of the Collegium Academicum, 5, Kogălniceanu Street

- 8.00 - 20.00 **Registration** of the participants at the Registration Desk
Location: Foyer of the Building of the Collegium Academicum, 5, Kogălniceanu Street
- 9.00 - 10.30 **Opening Ceremony**
Musical Opening of the Ceremony -Transylvania Quartet
Welcome addresses -
Andrei Marga, Rector, Babeş-Bolyai University
Ion Iliescu, President of Romania
Eric Froment, President EUA
- Plenary Session I: "Working together: Joint Degrees"**
Chair: Andrei Marga, Rector, Babeş-Bolyai University
- From Inter-universities cooperation to integrated programmes and joint degrees**, Eric Froment, President of EUA
- 1st Keynote speech
Working together in Europe and the world, Theodor Berchem, President DAAD
- 2nd Keynote speech
The benefits for Europe of Joint Degrees, Horst Fischer, President NOHA, Academic Director Institute for International Law of Peace and Armed Conflict
- 10.30 - 11.00 **Coffee break**
Location: Pyramid Restaurant, in the garden of the Collegium Academicum, 1, E. de Martonne Street
- Press Conference**
Location: Jean Monet Amphitheatre, Faculty of European Studies, 1, E. de Martonne Street
- 11.00 - 12.00 **Plenary Session II: "Case studies of institutional strategies for Joint Degrees"**
Chair: Georg Winckler, EUA Vice President
- 1st Case study.** Spain - University of Deusto, Julia Gonzales, Vice-Rector
2nd Case study. Romania - Babeş-Bolyai University, Wolfgang Breckner, Vice-Rector
3rd Case study. Hungary - Central European University, Istvan Teplan, Executive Vice-President
- 12.00 *Transfer by bus to the Inauguration of the Centre for International Cooperation of the Babeş-Bolyai University, 7, Pandurilor Street*
- 12.30 **Inauguration of the building of the Centre for International Cooperation** of the Babeş-Bolyai University by Ion Iliescu, the President of Romania, Eric Froment, EUA President, and Andrei Marga, Rector of the Babeş - Bolyai University
Location: Centre for International Cooperation and University Guest House Restaurant, 7, Pandurilor Street
- 13.00 *Lunch and cocktail reception*

14.30 - 15.30	<p>Plenary Session III. Joint Master Degrees: university strategies for working together</p> <p><i>Chair:</i> Carmen Ruiz-Rivas, Member of EUA Joint Master Project Steering Committee</p> <p>Presentation of EUA Joint Masters project results Jurgen Kohler, Chair of Joint Master Project Steering Committee</p> <p>Response and discussions from panel Friedrich Wittib, National Expert, European Commission, DG Education and Culture Stephan Neetens, Member of the Bologna Process Committee, ESIB Carsten Mantel, Coordinator TropEd Network for Education in International Health</p>
15.30 -16.00	<p>Coffee break <i>Location:</i> Pyramid Restaurant, in the garden of the Collegium Academicum, 1, E. de Martonne Street</p>
16.00 - 18.00	<p>Working Groups Session I: "Preconditions for successful partnerships: processes structures and resources needed to achieve strategic goals"</p> <p>Theme A: Joint programmes (Ba/Ma/Phd) - developing an institutional strategy.</p> <p>Group 1 <i>Location:</i> Nicolae Iorga Amphitheatre, Central Building of the Babeş-Bolyai University, 1, M. Kogălniceanu Street</p> <p>Group 2 <i>Location:</i> Vasile Bogrea Amphitheatre, Central Building of the University, 1, M. Kogălniceanu Street</p> <p>Theme B: Anchoring Joint Masters in the institution - lessons from the EUA Pilot project <i>Location:</i> E. Speranția Amphitheatre, Faculty of Law, 11, A. Iancu Street</p> <p>Theme C: Particular challenges of working together at doctoral level <i>Location:</i> Ionașcu Amphitheatre, Faculty of Law, 11, A. Iancu Street</p> <p>Theme D: Towards a European Label for higher education institutions: demonstrating the European dimension in institutional practice <i>Location:</i> Jean Monet Amphitheatre, Faculty of European Studies, 1, E. de Martonne Street</p>
20.30 - 22.30	<p>Reception hosted by Ion Iliescu, President of Romania <i>Location:</i> Restaurant of the Victoria Hotel, 52-56, 21 Decembrie 1989 Street</p>

B. 5th EUA CONFERENCE PROGRAMME

Saturday, 25 October

9.00 -10.30

Working Groups Session II: "Preconditions for successful partnerships: processes, structures and resources needed to achieve strategic goals"
(Coffee will be offered during session)

Theme A: Joint programmes (Ba/Ma/Phd) - developing an institutional strategy

Group 1

*Location: 001 Amphitheatre, Faculty of Economics,
58-60, T. Mihali Street*

Group 2

*Location: 036 Amphitheatre, Faculty of Economics,
58-60, T. Mihali Street*

Theme B: Anchoring Joint Masters in the institution - lessons from the EUA Pilot project

*Location: 022 Amphitheatre, Faculty of Economics,
58-60, T. Mihali Street*

Theme C: Particular challenges of working together at doctoral level

*Location: 009 Amphitheatre, Faculty of Economics,
58-60, T. Mihali Street*

Theme D: Towards a European Label for higher education institutions: demonstrating the European dimension in institutional practice

*Location: 026 Amphitheatre, Faculty of Economics,
58-60, T. Mihali Street*

10.30 - 11.00

Transfer by bus to Collegium Academicum 5, Kogălniceanu Street

11.00 - 13.00

Plenary Session IV: Presentation of Working Group Conclusions and recommendations

Conference Closing

Chair: Eric Froment, EUA President



C. POST CONFERENCE EXCURSIONS AND MEETINGS

Saturday, 25 October

- 13.30 - 14.00 *Transfer by bus to the Transylvania Hotel for lunch*
- 13.30 - 16.00 **Lunch** for all participants and companions hosted by the sponsors of the Babeş-Bolyai University
Location: Restaurant of the Transylvania Hotel, 1-3, Călăraşilor Street
- 13.30 - 14.30 **Introduction to the EUA for the Romanian member and non-member Universities**
Location: Aula Magna, Central Building of the University, 1, M. Kogălniceanu Street
- 17.00 - 19.00 **Guided City Tour**
Location: shuttle bus picks up participants from the Transylvania Hotel and all conference hotels (see bus schedule).
- 18.00 - 19.00 **Opera Concert**
Location: National Theatre Building, 24, Ştefan cel Mare Square
- 18.30 - 19.30 **Meeting of the EUA Board with the students of the Babeş-Bolyai University**
Location: Aula Magna, Central Building of the University, 1, M. Kogălniceanu Street
- 20.30 - 22.30 **Dinner hosted by the Rector of the Babeş-Bolyai University**
Location: Pyramid Restaurant, in the garden of the Collegium Academicum, 1, E. de Martonne Street

Sunday, 26 October

Transylvania - History and Multiculturalism

Route: Cluj Napoca - Alba Iulia - Sibiu - Sibiel - Alba Iulia - Cluj Napoca

Route length: approx. 350 km

Highlights:

Sibiu - Historical Centre, Brukenthal Palace, Evangelical Cathedral, Stairs Passage

Sibiel - A beautiful Romanian village with folkloric tradition

Alba Iulia - "Reîntregirea Neamului" Cathedral, Roman-Catholic Cathedral, Fortress

9.00 **Departure** from Cluj

13.00 **Lunch** at Sibiu, Palace Restaurant

19.00 **Arrival** in Cluj

20.30 - 22.30 **Dinner.**

Location: Pyramid Restaurant, in the garden of the Collegium Academicum, 1, E. de Martonne Street

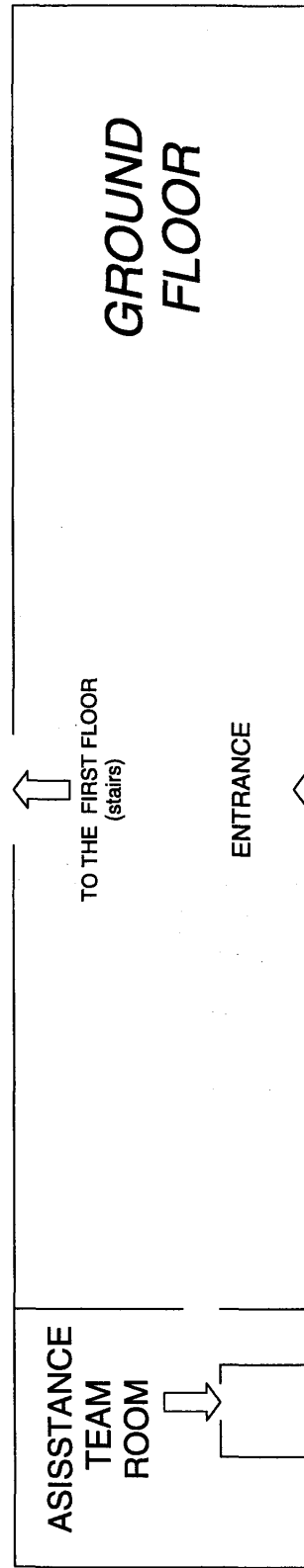
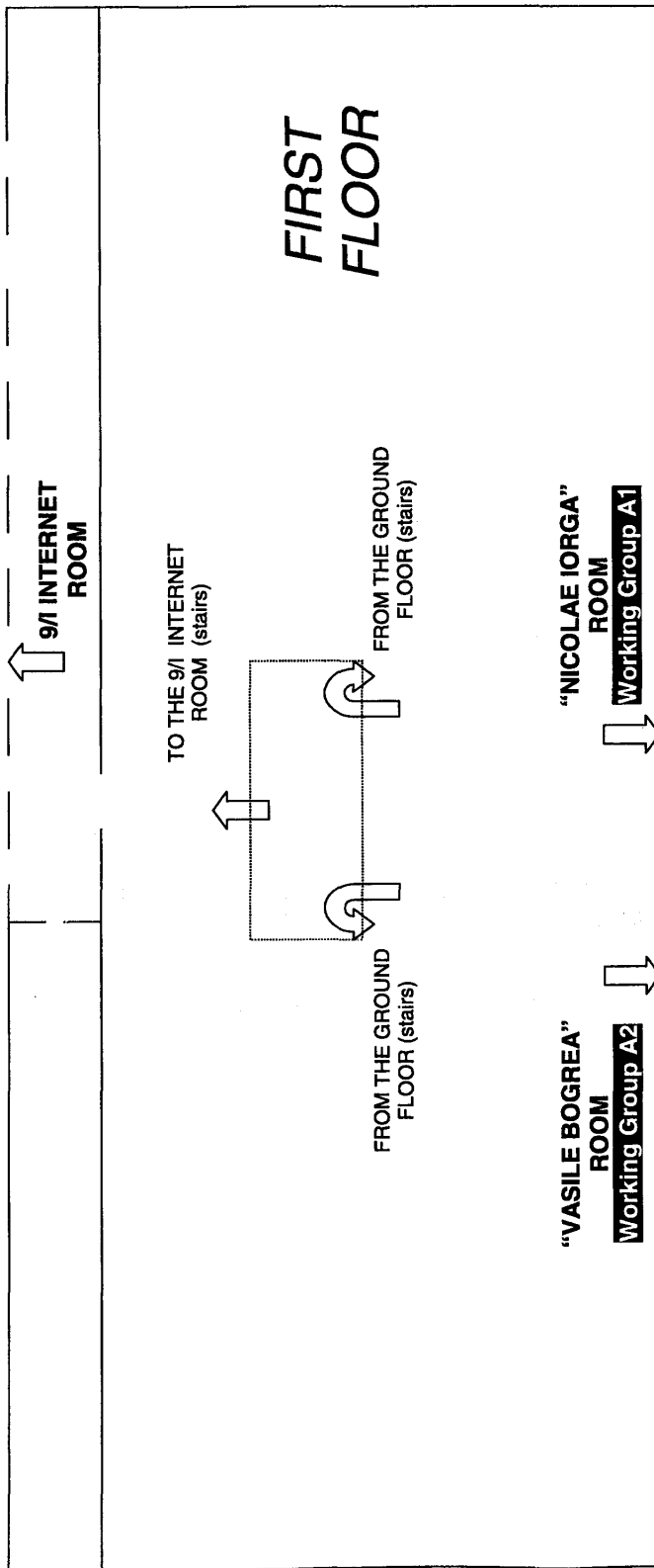

CENTRAL BUILDING OF "BABEȘ-BOLYAI UNIVERSITY"

**FACULTY OF EUROPEAN STUDIES
 INSTITUTE FOR EUROPEAN RESEARCH
 COLLEGIUM ACADEMICUM
 PYRAMID**

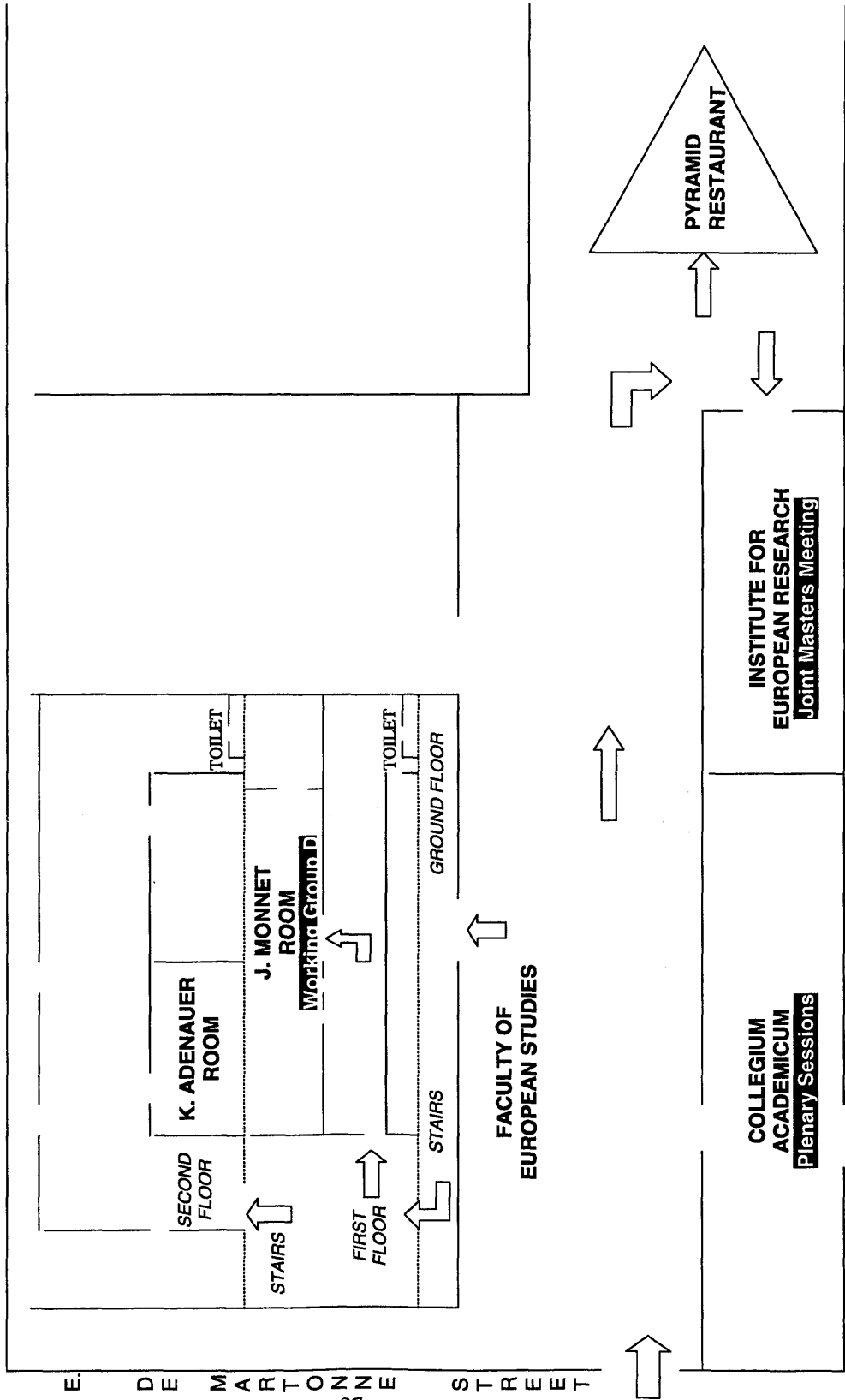

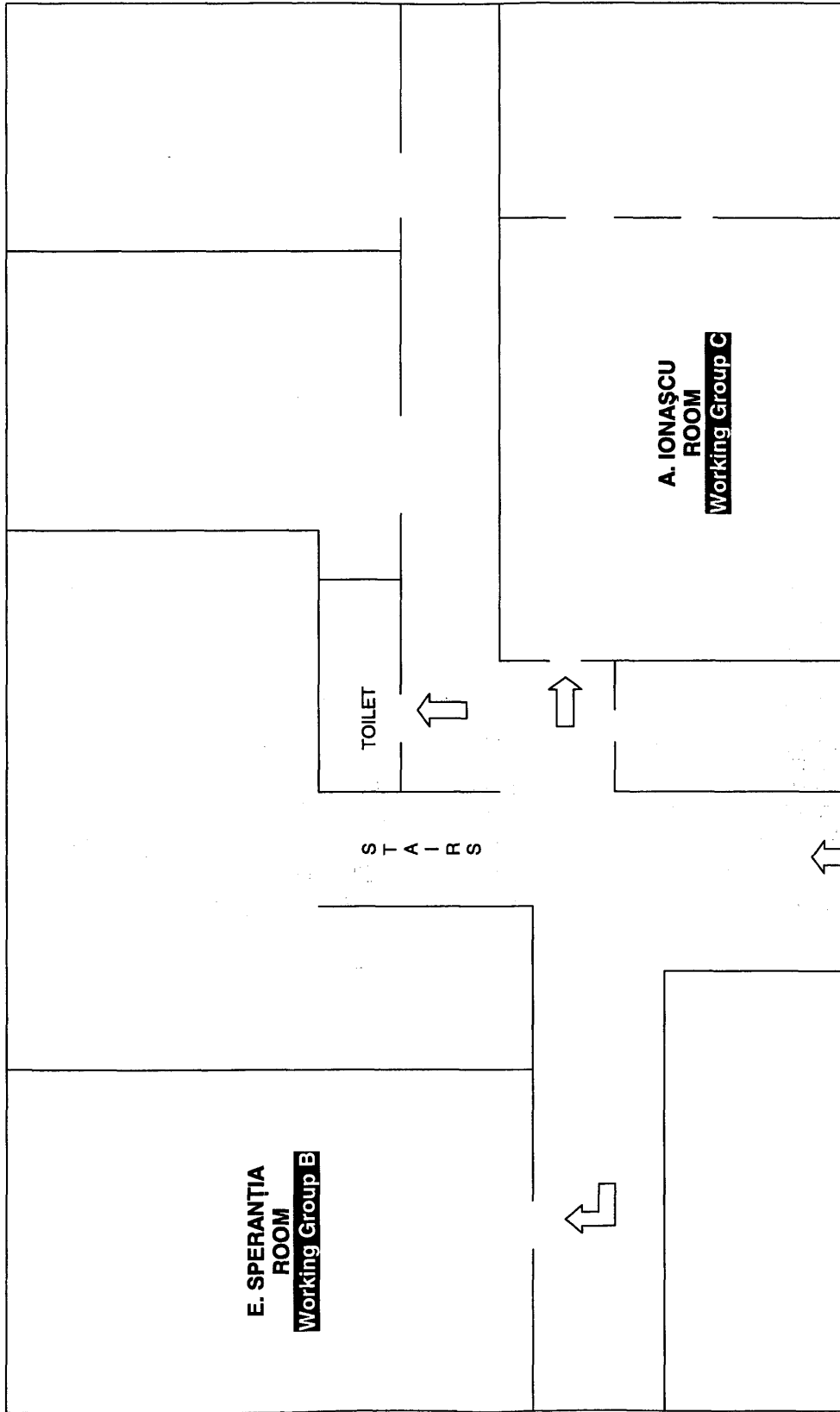

AVRAM IANCU STREET

FACULTY OF LAW

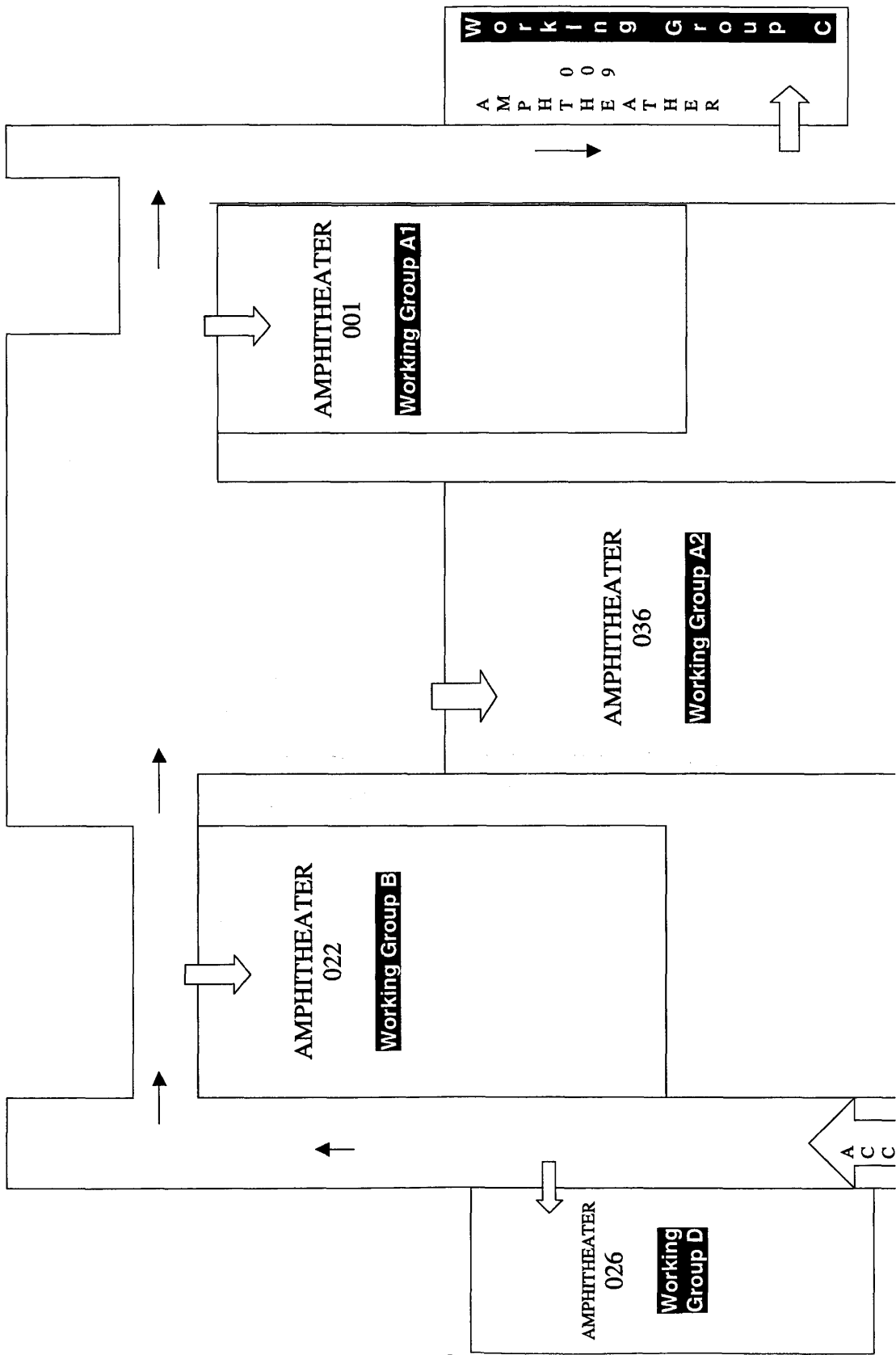

Useful Information

I. Useful Numbers:

1. Police: 955
2. Fire Department: 981
3. Medical Emergency: 961

II. Exchange Houses:

1. Macrogrup SRL: Str. Gh. Doja 12
2. Saker Comp. SRL: Str. Iuliu Maniu 6 (594711)
3. Prima Exchange SRL: Str. Andrei Saguna 34-36 (434026)

III. Pharmacies

1. Europharm (L-S 8-22; D: 8-14); Str. Napoca 8
2. Galenus: Calea Motilor 110 (595418)
3. Hedera (Regele Ferdinand 36; 530077)
4. Kamill: P-ta Mihai Viteazul 6 (432610)
5. Farmacia Nr. 1: P-ta Unirii 34 (594606)

IV. Hospitals:

1. Astromedica: Clinicilor 3-5; (431745)
2. Spitalul CFR: Str. G. Bilascu 18; (598278)
3. Spitalul Clinic Judetean: Str. Clinicilor 3-5 (597852)
4. Spitalul Clinic de Adulti: Str. Constanta 5; (530614)

V. Post Office:

1. Posta Centrala: Str. Regele Ferdinand 33 (598483)

VI. Banks:

1. ABN AMRO: Str. Dorobanților 70, et. 4 (413300)
2. BANC POST; Str. M. Eminescu 2; (592525)
3. Banca Comerciala Romana: Str. G. Baritiu 10-12 (591227)

VII. Laundries:

1. Asklepios (Str. Clinicilor 9; 598581)

VIII. Cinemas:

1. „Arta” – Str. Universitatii 3; 596616
2. „Republica” – P-ta Mihai Viteazul 11; 530521)
3. „Victoria” – Bd. Eroilor 61; (598561)

IX. Theatres:

1. Teatrul National – P-ta Stefan cel Mare 24 (591799)
2. Teatrul Maghiar de Stat – Emil Isac 26-28 (593469)

X. Restaurants:

1. Castellari – Str. Observatorului 2; 524100
2. Continental – Str. Napoca 1; 591441
3. Hubertus – Str. 21 Decembrie 22
4. Mary's – Str. Pavlov 27
5. Roata – Piata Muzeului
6. Lugano – Str. G. Clemenceau nr. 4

XI. Hotels:

1. University Guest House - Str. Pandurilor, nr.7 0040264584315
2. Topaz Str. Septimiu Albini, nr. 10 0040264414021
3. Transylvania Str. Calarasilor , nr.1/3 40264432059
4. Onix Str. Septimiu Albini, nr. 12 40264414076
5. Casa Alba Str. Emil Racovita, nr.22 40264432757
6. Victoria Bdul 21 Decembrie 52/56 40264597563



5th EUA CONFERENCE

UNIVERSITIES WORKING TOGETHER IN EUROPE: Integrated Programmes and Joint Degrees - a hallmark of the European Higher Education Area

Cluj

24-25 October 2003

LIST OF DISCUSSION GROUPS

(as at 21 October 2003)

Participants have been assigned to one group in each session. The organisers have done their best to respect individual requests insofar as these were expressed within the deadline. Since a number of criteria were used to put the groups together, we strongly request participants to stay in the groups to which they have been assigned. To find your groups, please see first the alphabetical list at the back.

Les participants ont été affectés à un groupe dans chaque session. Les organisateurs se sont efforcés de respecter les souhaits émis, dans la mesure où ils en ont été informés dans les délais. La répartition des groupes répondant à un ensemble de critères, nous prions instamment les participants de rester dans les groupes où figure leur nom. Pour trouver dans quels groupes vous vous trouvez, veuillez tout d'abord consulter la liste alphabétique.

DISCUSSION GROUPS

Discussion group A – **Group 1:**

Joint programmes (Ba/Ma/Phd) - developing an institutional strategy

Chair: Professor Roderick FLOUD, EUA Board, Vice-Chancellor London Metropolitan University, UK

Rapporteur: Lewis PURSER, EUA

Discussion group A – **Group 2:**

Joint programmes (Ba/Ma/Phd) - developing an institutional strategy

Chair: Professor Andrejs RAUHVARĢERS, Secretary General, Latvian Rectors' Council, Riga

Rapporteur: Ms Tish BOURKE, Manager Europe Unit, Universities UK, London

Discussion group B:

Anchoring Joint Masters in the institution - lessons from the EUA Pilot project

Chair: Dr Carmen RUIZ-RIVAS, Professor, Universidad Autonoma de Madrid, Spain

Presenter: Professor Dr Jurgen KOHLER, Former Rector, Ernst-Moritz-Armdt-Universität Greifswald, Germany

Rapporteur: Kate GEDDIE, EUA

Discussion group C

Particular challenges of working together at doctoral level

Chair: Dr Jan SADLAK, Director, Unesco-Cepes, Bucharest, Romania

Presenter: Ms Julia Maria GONZALEZ FERRERAS, Vice Rector for international Affairs, University of Deusto, Spain

Rapporteur: Mrs Matei LIVIU, Academic Secretary, Central European University, Budapest, Hungary

Discussion group D

**Towards a European Label for higher education institutions:
demonstrating the European dimension in institutional practice**

Chair: Eric FROMENT, EUA President

Presenter: Lesley WILSON, EUA Secretary General

Rapporteur: David CROSIER, EUA

Friday, 16.00 – 18.00

Location: Nicolae Iorga Amphitheatre, Central Building of the Babeş-Bolyai University, 1, M. Kogălniceanu Street

Saturday, 09.00 – 10.30

Location: 001 Amphitheatre, Faculty of Economics, 58-60, T. Mihali Street

**Discussion group A – Group 1:
Joint programmes (Ba/Ma/Phd) - developing an institutional strategy**

Chair: Professor Roderick FLOUD, EUA Board, Vice-Chancellor London Metropolitan University,

Rapporteur: Lewis Purser, EUA

Natasha	DOSHI	Vorarlberg University of Applied Sciences	Dornbirn	Austria
Borisa	STAROVIC	University of Srpsko Sarajevo	Lukavica	Bosnia and Herzegovina
Galya	GERCHEVA-NESTOROVA	Varna Free University "Chernorizets Hrabar"	Varna	Bulgaria
Ante	UGLESIC	University of Zadar	Zadar	Croatia
Helena Jasna	MENCER	University of Zagreb	Zagreb	Croatia
Gerogory	MAKRIDES	Intercollege-Cyprus	Nicosia	Cyprus
Susanne	BJERREGAARD	The Danish Rectors' Conference	Copenhagen	Denmark
Katrin	NIGLAS	Tallinn Pedagogical University	Tallinn	Estonia
Jan	VERWIJNEN	University of Art and Design Helsinki	Helsinki	Finland
Tarja	HYPPONEN	University of Turku, Baltic Sea Regions Studies	Turku	Finland
Dominique	MELLET	Université Jean Monnet Saint-Etienne	Saint-Etienne	France
Marie-Paule	ROUSSEL	Université Charles de Gaulle-Lille	Villeneuve d'Ascq	France
Stefanie	HOFMANN	Accreditation, Certification & Quality Assurance Inst.	Bayreuth	Germany
Nina	SCHULTE DOUKA--	Justus-Liebig-University Giessen	Giessen	Germany
Ekaterini	KABITOGLOU	Aristotle University of Thessaloniki	Thessaloniki	Greece
Jozsef	TEMESI	Budapest University of Economic Sciences	Budapest	Hungary
György	FODOR	Pázmány Péter Catholic University	Budapest	Hungary
Zoltán	ABÁDI-NAGY	University of Debrecen	Debrecen	Hungary
István	MOLNÁR	Szent István University, Gödöllő	Gödöllő	Hungary
Jose Luis	GOTOR	Università di Roma "Tor Vergata"	Rome	Italy
Ojars	JUDRUPS	University of Latvia	Riga	Latvia
Ingebjørg	BIRKELAND	Center for international University Co-operation, SIU	Bergen	Norway
Florian	KUZNIK	University of Economics	Katowice	Poland
Da-Rouin	TOU-CHIU	Graduate Institute of Euro Studies, Tamkang Univ.	Taipei	Republic of China
Vadim	COJOCARU	Academy of Economic Sciences Moldova	Chişinău	Republic of Moldova
Aurel	ARDELEAN	Universitatea De Vest Vasile Goldis	Arad	Romania
Andrei	MARGA	Babes-Bolyai University	Cluj	Romania
Serban	AGACHI	Babes-Bolyai University	Cluj	Romania

Ioan	SBARCIU	University of Art and Design	Cluj	Romania
Virgil	BREABAN	Ovidius University Of Constantza	Constanta	Romania
Mihai	IACOBESCU	Ştefan cel Mare University of Suceava	Suceava	Romania
Vasile	BOLOS	Universitatea Petru Maior Targu-Mures	Targu-Mures	Romania Serbia and Montenegro
Bozin	VLASKOVIC	University of Kragujevac	Kragujevac	Romania Serbia and Montenegro
Mikulas	SUPIN	Slovak Rectors' Conference	Bratislava	Slovak Republic
Daniel	KLUVANEC	Constantine The Philosopher University in Nitra	Nitra	Slovak Republic
Ivan	ROZMAN	University of Maribor	Maribor	Slovenia
Jaume	URGELL	Ministry of Universities- Government of Catalonia	Barcelona	Spain
Jose Luis Francesc	IRIARTE	Universidad Publica de Navarra	Pamplona	Spain
Xavier	GRAU VIDAL	Universitat Rovira i Virgili	Tarragona	Spain
Einar	LAURITZEN	Uppsala University	Uppsala	Sweden
Louissette	ZANINETTI	University of Geneva	Geneva	Switzerland
Crispin	HUGENSCHMIDT VAN DER DUYN	University of Zurich	Zurich	Switzerland
Frank A.	SCHOUTEN	Tilburg University	Tilburg	The Netherlands
Valentin	SMYNTYNA	Odesa Mechnikov National University	Odesa	Ukraine
Oleh	SHABLIY	Temopil State Ivan Pul'uj Technical University	Temopil	Ukraine
Ihor	LUTSIV	Temopil State Ivan Pul'uj Technical University	Temopil	Ukraine
John	PERKINS	Oxford Brookes University	Oxford	United Kingdom

Friday, 16.00 – 18.00

Location: Vasile Bogrea Amphitheatre, Central Building of the University, 1, M. Kogălniceanu Street

Saturday, 09.00 – 10.30

Location: 036 Amphitheatre, Faculty of Economics, 58-60, T. Mihali Street

**Discussion group A – Group 2:
Joint programmes (Ba/Ma/Phd) - developing an institutional strategy**

Chair: Professor Andrejs RAUHVARERS, Secretary General, Latvian Rectors' Council, Riga

Rapporteur: Ms Tish BOURKE, Manager Europe Unit, Universities UK, London

Gunther	LISCHKA	Vienna Univ. of Economics & Business Admin Conseil Interuniversitaire de la Communauté française (C.I.U.F.)	Vienna	Austria
Marc	VANDEUR		Brussels	Belgium
Damir	MAGAS AVGOUSTIDOU- KYRIACOU	University of Zadar	Zadar	Croatia
Elena		University of Cyprus	Nicosia	Cyprus
Joergen	OESTERGAARD	Aalborg University	Aalborg	Denmark
Arne	CARLSEN	The Danish University of Education	Copenhagen	Denmark
Tõnu	LEHTSAAR	University of Tartu	Tartu	Estonia
Tapio	MARKKANEN	Finnish Council of University Rectors	Helsinki	Finland
Tenho	TAKALO	University of Tampere	Tampere	Finland
Marie-Cecile	CLARE	Universite de Toulouse II-Le Mirail	Toulouse	France
Philippe	OLIVIER	Universite Paris 13	Villetaneuse	France
Werner	VAETH	Freie Universitaet Berlin	Berlin	Germany
Christian	TAUCH	Hochschulrektorenkonferenz (HRK)	Bonn	Germany
István	TEPLÁN	Central European University	Budapest	Hungary
Antal	BOKAY	University of Pecs	Pecs	Hungary
Gábor	SZABÓ	University of Szeged	Szeged	Hungary
Zoltán	GAÁL	University of Veszprém University of Iceland / National Rectors Conference of Iceland	Veszprém	Hungary
Tryggvi	THÓRHALLSSON		Reykjavik	Iceland
Raffaella	ANGELUCCI	IULM University – Milan	Milan	Italy
Alvydas	PUMPUTIS	Law University of Lithuania	Vilnius	Lithuania
Marzena	KAWCZYNSKA-TYRAN	The Academy of Humanities and Economics	Lodz	Poland
Raul Filipe	XISTO BRUNO DE SOUSA	Technical University of Lisbon	Lisboa	Portugal
Moise Ioan	ACHIM	2 December 1918 University The National School of Political Studies and Public Administration	Alba Iulia	Romania
Vasile	SECARES		Bucharest	Romania
Vasile	CRISTEA	Babes-Bolyai University	Cluj	Romania
Nicolae	BOCSAN	Babes-Bolyai University	Cluj	Romania
Mircea	IVANESCU	University of Craiova Universitatea de Stiinte Agricole si Medicina Veterinara	Craiova	Romania
Nicolae	MUNTEANU		Iasi	Romania

Aurel	BURCIU	Ștefan cel Mare University of Suceava	Suceava	Romania
Cornel	HARANGUS	Tibiscus University	Timisoara	Romania
Vladimir	EGOROV	Ivanovo State University	Ivanovo	Russia
Ruzica	NIKOLIC	University of Kragujevac	Kragujevac	Serbia and Montenegro
Magdalena	BELKOVA	Comenius University Bratislava	Bratislava	Slovak Republic
Maria	KOZUCHOVA	Slovak Rectors' Conference	Bratislava	Slovak Republic
Lucka	LORBER	Ministry of Education, Science and Sport	Ljubliana	Slovenia
Andrejka	JUG	Ministry of Education, Science and Sport	Ljubliana	Slovenia
M. Dolors	RIBA	Universitat Autònoma de Barcelona	Bellaterra	Spain
Per	LEANDER	Education & Research Administration	Luleå	Sweden
Zoe	GHIEMETTI	University of Bern	Bern	Switzerland
Yasmine	INAUEN	University of Zurich	Zurich	Switzerland
Roger J.	VAN DEN BERGH	Erasmus University Rotterdam	Rotterdam	The Netherlands
N. Lerzan	ÖZKALE	Istanbul Technical University	Istanbul	Turkey
Olexandr	YASEV	National Metallurgical Academy of Ukraine	Dnipropetrovsk	Ukraine
Victor	GRINEVYCH	Odessa Mechnikov National University	Odessa	Ukraine
Susan	HUNTER	University of Leeds	Leeds	United Kingdom
Susan	SUTTON	Indiana University	Indianapolis	USA

Friday, 16.00 – 18.00

Location: E. Speranția Amphitheatre, Faculty of Law,
11, A. Iancu Street

Saturday, 09.00 – 10.30

Location: 022 Amphitheatre, Faculty of Economics,
58-60, T. Mihali Street

**Discussion group B:
Anchoring Joint Masters in the institution - lessons from the EUA Pilot project**

Chair: Dr Carmen RUIZ-RIVAS, Professor, Universidad Autonoma de Madrid, Spain

Presenter: Professor Dr Jurgen KOHLER, Former Rector, Ernst-Moritz-Armdt-Universität Greifswald, Germany

Rapporteur: Kate Geddie, EUA

Pellumb	BERBERI	Polytechnic University of Tirana	Tirana	Albania
Peter	PUSKAS	ESIB- National Unions of Students in Europe	Brussels	Belgium
Henrik Toft	JENSEN	Roskilde University	Roskilde	Denmark
Osmo	LAMPINEN	Ministry of Education	Helsinki	Finland
Catherine	KIRBY-LEGIER	Aix-Marseille III (France)	Aix-en-Provence	France
John	TUPPEN	Universite Joseph Fourier - Grenoble 1	Grenoble	France
Claire	PONTAL	Community of European Management Schools	Jouy-en-Josas	France
Monique	CHASSAGNOL	University of Paris X-Nanterre	Nanterre	France
Ferenc	HUSVÉTH	University of Veszprém	Veszprém	Hungary
Rinaldo	BERTOLINO	University of Turin	Torino	Italy
Leiv K.	SYDNES	University of Bergen	Bergen	Norway
Barbara	CENTKOWSKA	University of Economics	Katowice	Poland
Makary	STASIAK	The Academy of Humanities and Economics	Lodz	Poland
Ryszard	STRASZYNSKI	Maria Curie-Skłodowska University	Lublin	Poland
Marek	ROCKI	Warsaw School of Economics	Warsaw	Poland
Alice	NEWTON	Universidade do Algarve	Faro	Portugal
Mu-Li N	LU	Ministry of Education	Taipei	Republic of China
Jei-Cheng	CHENG	National Chengchi University	Taipei	Republic of China
Iacob	MARZA	1 December 1918 University	Alba Iulia	Romania
Constantin	BUȘE	Universitatea din București	Bucharest	Romania
Genevieve	ICHARD	Ambassade de France en Roumanie	Bucharest	Romania
Teodor	PRECUPANU	Alexandru Ioan Cuza University of Iasi	Iasi	Romania
Gheorghe	BARBU	Pitești University	Pitești	Romania
Dan	DUȘE	University "Lucian Blaga" of Sibiu	Sibiu	Romania
Simona Ruxanda	DRAGAN	University Of Medicine and Pharmacy "Victor Babes"	Timisoara	Romania
Gennady G.	GLADKOV	MGIMO University	Moskow	Russia
Ivan	LEBAN	University of Ljubljana	Ljubljana	Slovenia
Albert	WIJNEN	University of Amsterdam	Amsterdam	The Netherlands

Wicher	SCHREUDERS	Erasmus University Rotterdam	Rotterdam	The Netherlands
Lale	DURUIZ	Istanbul Bilgi University	Istanbul	Turkey
Nimet Hulya	TALU	Istanbul University	Istanbul	Turkey
Keith	CHAPMAN	Coventry University	Coventry	United Kingdom
Gerard	MADILL	Universities Scotland	Edinburgh	United Kingdom
Howard	DAVIES	London Metropolitan	London	United Kingdom
Andrew	FINCH	University of Salford	Salford	United Kingdom

Friday, 16.00 – 18.00

Location: Ionaşcu Amphitheatre, Faculty of Law, 11, A. Iancu Street

Saturday, 09.00 – 10.30

Location: 009 Amphitheatre, Faculty of Economics, 58-60, T. Mihali Street

Discussion group C
Particular challenges of working together at doctoral level

Chair: Dr Jan SADLAK, Director, Unesco-Cepes, Bucharest, Romania

Presenter: Ms Julia Maria GONZALEZ FERRERAS, Vice Rector for international Affairs, University of Deusto, Spain,

Rapporteur: Mrs Matei LIVIU, Academic Secretary, Central European University, Budapest, Hungary

Konstantinos	MOULOPOULOS	University of Cyprus	Nicosia	Cyprus
Marios	ANTONIADES	Cyprus Council For The Recognition Of Higher Education Qualifications (KYSATS) NARIC	Nicosia	Cyprus
Priit	REISKA	Tallinn Pedagogical University	Tallinn	Estonia
Hannele	NIEMI	University of Helsinki	Helsinki	Finland
Jose	SAVOYE	Université de Lille 2	Lille	France
Claude	BURLET	Université Henri Poincaré	Nancy	France
Jochen	HELLMANN	University of Hamburg	Hamburg	Germany
Joachim	GRISPOLAKIS	Technical University of Crete	Chania	Greece
Istvan	BILIK	Confederation of Hungarian Conferences on Higher Education	Budapest	Hungary
Akos	DETREKOI	Budapest University of Technology and Economics	Budapest	Hungary
Péter	SÓTÓNYI	Semmelweis University	Budapest	Hungary
György	BAZSA	University of Debrecen	Debrecen	Hungary
Aladar	NAGY	Miskolc University	Miskolc	Hungary
Frank	MCMAHON	Dublin Institute of Technology	Dublin	Ireland
Angelijā	VALANCIUTE	Kaunas University of Medicine, Lithuania	Kaunas	Lithuania
Birute	POCIUTE	Vilnius University	Vilnius	Lithuania
Ingunn	ANDERSEN	Agricultural University of Norway	Aas	Norway
Mirosław	LOBODA	Maria Curie-Skłodowska University	Lublin	Poland
Andrzej	KRASNIEWSKI	CRASP - Conference of Rectors of Academic Schools in Poland	Warsaw	Poland
Antonio	DE BRITO FERRARI	University of Aveiro	Aveiro	Portugal
Jow-Fei	HO	Ministry of Education	Taipei	Republic of China
Wei-Fan	KUO	National Taiwan Normal University	Taipei	Republic of China
Ioan	DUMITRACHE	University Politehnica of Bucharest	Bucharest	Romania
Lidia	CRISTEA	Universitatea Română de Ştiinţe şi Arte	Bucharest	Romania
Stefan	DIACONESCU	University of Agricultural Sciences and Veterinary Medicine	Bucuresti	Romania
Benone	PUŞCĂ	Universitatea "Danubius" din Galati	Galati	Romania

Stefan Iosif	DRAGULESCU	University Of Medicine and Pharmacy "Victor Babes"	Timisoara	Romania
Marina	LARIONOVA	State University-Higher School of Economics	Moscow	Russia
Victor	KIRILLOV	MGIMO University	Moscow	Russia
Ljiljana	TODOROVIC	Ministry of Education and Sports	Belgrade	Serbia and Montenegro
Vladisav	STEFANOVIC	University of Nis	Nis	Serbia and Montenegro
Nebojsa	NOVKOVIC	University of Novi Sad	Novi Sad	Serbia and Montenegro
Juraj	SVEC	Slovak Medical University	Bratislava	Slovak Republic
Jan	BUJNAK	University of Zilina	Zilina	Slovak Republic
Stephen	HWANG	Karlstad University	Karlstad	Sweden
André	HURST	University of Geneva	Geneva	Switzerland
Nathalie	JANZ	University of Lausanne	Lausanne	Switzerland
Laura	CAMPOY-GOMEZ	The University of Salford, Information Systems Institute	Salford	United Kingdom

Friday, 16.00 – 18.00

Location: Jean Monet Amphitheatre, Faculty of European Studies, 1, E. de Martonne Street

Saturday, 09.00 – 10.30

Location: 026 Amphitheatre, Faculty of Economics, 58-60, T. Mihali Street

Discussion group D
**Towards a European Label for higher education institutions:
demonstrating the European dimension in institutional practice**

Chair: Eric Froment, EUA President

Presenter: Lesley Wilson, EUA Secretary General

Rapporteur: David Crosier, EUA

Karin	RIEGLER	Austrian Rectors' Conference	Vienna	Austria
Georg	WINCKLER	Austrian Rectors' Conference	Vienna	Austria
Hazrat	AGHABAYLI	Department of International Relations, Baku State University	Baku	Azerbaijan
Stanislav	PROCHAZKA	Mendel University of Agriculture and Forestry , Brno	Brno	Czech Republic
Tomas	CERMAK	VSB-Technical University of Ostrava	Ostrava	Czech Republic
Patrick	FRANJOU	Conférence des Présidents d 'Université	Paris	France
Jean-Luc	BASILLE	Institut National Polytechnique de Toulouse tropEd Network for Education in International Health	Toulouse	France
Carsten	MANTEL		Berlin	Germany
Gyorgy	BIRO	University of Miskolc Szegedi Tudományegyetem (University of Szeged)	Miskolc	Hungary
Béla	PUKÁNSZKY		Szeged	Hungary
Maria	CAVALLINI	Conference of Italian University Rectors (CRUI)	Rome	Italy
Ola	STAVE	Norwegian Councils for Higher Education	Oslo	Norway
Andrzej	CEYNOWA	University of Gdansk	Gdansk	Poland
Jan	WOJTYLA	University of Economics	Katowice	Poland
Andrzej	KORBEL	University of Science and Technology Jagiellonian University, Conference of Rectors of Academic Schools in Poland	Krakow	Poland
Franciszek	ZIEJKA	Technical University of Lodz (Politechnika Lodzka)	Kraków	Poland
Edward	JEZERSKI		Lodz	Poland
Wojciech	TYGIELSKI	Warsaw University	Lodz	Poland
Stela	DRĂGULIN	Transylvania University of Brasov	Warsaw	Poland
Mihaela Sofia	DINU	Romanian American University	Brasov	Romania
Aurel	MARC	Academia de Muzică Gheorghe Dima	Bucharest	Romania
Paul	SZILAGYI	Sapientia Hungarian University of Transilvania University of Agricultural Sciences and Veterinary Medicine	Cluj	Romania
Liviu Alexandru	MĂRGHITAȘ		Cluj	Romania

Victor	CIUPINA	Ovidius University Of Constantza	Constanta	Romania
Ioan	POP	Universitatea Emanuel din Oradea	Oradea	Romania
Constantin	OPREAN	Lucian Blaga University of Sibiu	Sibiu	Romania
Marius	SABAU	University of Medicine and Pharmacy	Targu-Mures	Romania
Pavel	SURA	Comenius University In Bratislava	Bratislava	Slovak Republic
Luis	ESCOBAR DE LA SERNA	Universidad San Pablo CEU	Madrid	Spain
Concepción	MAROTO ÁLVAREZ	Universidad Politécnica de Valencia Conference of the universities of applied sciences of Switzerland	Valencia	Spain
Fredy	SIDLER		Berne	Switzerland
Alex	OLDE KALTER	European Association for International Education	Amsterdam	The Netherlands
Mark	FREDERIKS	Netherlands Accreditation Organisation	The Hague	The Netherlands
Nebahat	SARI	Cukurova University	Adana	Turkey
Yilmaz	ZEKI	Erciyes University	Kayseri	Turkey
Caroline	HALL	University of Brighton	Brighton	United Kingdom
David	YOUNG	Universities UK	London	United Kingdom

PARTICIPANTS' ALPHABETICAL INDEX

INDEX ALPHABETIQUE DES PARTICIPANTS

(the figures below refer to the groups assigned to each participant)

(les chiffres ci-dessous indiquent les groupes où se trouve chaque participant)

ABÁDI-NAGY, Zoltán	A 1	GERCHEVA-NESTOROVA, Galya	A 1
ACHIM, Moise Ioan	A 2	GLESIC, Ante	A 1
AETH, Werner	A 2	GHIEMMETTI, Zoe	A 2
AGACHI, Serban	A 1	GLADKOV, Gennady G.	B
AGHABAYLI, Hazrat	D	GOTOR, Jose Luis	A 1
ANDERSEN, Ingunn	C	GRAU VIDAL, Francesc Xavier	A 1
ANGELUCCI, Raffaella	A 2	GRINEVYCH, Victor	A 2
ANTONIADES, Marios	C	GRISPOLAKIS, Joachim	C
ARDELEAN, Aurel	A 1	HALL, Caroline	D
AVGOUSTIDOU, Elena	A 2	HARANGUS, Cornel	A 2
BARBU, Gheorghe	B	HELLMANN, Jochen	C
BASILLE, Jean-Luc	D	HO, Jow-Fei	C
BAZSA, György	C	HOFMANN, Stefanie	A 1
BELKOVA, Magdalena	A 2	HUGENSCHMIDT, Crispin	A 1
BERBERI, Pellumb	B	HUNTER, Susan	A 2
BERTOLINO, Rinaldo	B	HURST, André	C
BILIK, Istvan	C	HUSVÉTH, Ferenc	B
BIRKELAND, Ingebjørg	A 1	HWANG, Stephen	C
BIRO, Gyorgy	D	HYPONEN, Tarja	A 1
BJERREGAARD, Susanne	A 1	IACOBESCU, Mihai	A 1
BOCSAN, Nicolae	A 2	ICHARD, Genevieve	B
BOKAY, Antal	A 2	INAUEN, Yasmine	A 2
BOLOS, Vasile	A 1	IRIARTE, Jose Luis	A 1
BREABAN, Virgil	A 1	IVANESCU, Mircea	A 2
BUJNAK, Jan	C	JANZ, Nathalie	C
BURCIU, Aurel	A 2	JENSEN, Henrik Toft	B
BURLET, Claude	C	JEZIERSKI, Edward	D
BUŞE, Constantin	B	JUDRUPS, Ojars	A 1
CAMPOY-GOMEZ, Laura	C	JUG, Andrejka	A 2
CARLSEN, Arne	A 2	KAWCZYNSKA-TY., Marzena	A 2
CAVALLINI, Maria	D	KIRBY-LEGIER, Catherine	B
CENTKOWSKA, Barbara	B	KIRILLOV, Victor	C
CERMAK, Tomas	D	KLUVANEC, Daniel	A 1
CEYNOWA, Andrzej	D	KORBEL, Andrzej	D
CHAPMAN, Keith	B	KOZUCHOVA, Maria	A 2
CHASSAGNOL, Monique	B	KRASNIEWSKI, Andrzej	C
CHENG, Jei-Cheng	B	KUO, Wei-Fan	C
CIUPINA, Victor	D	KUZNIK, Florian	A 1
CLARE, Marie-Cecile	A 2	LAMPINEN, Osmo	B
COJOCARU, Vadim	A 1	LARIONOVA, Marina	C
CRISTEA, Vasile	A 2	LAURITZEN, Einar	A 1
CRISTEA, Lidia	C	LEANDER, Per	A 2
DAVIES, Howard	B	LEBAN, Ivan	B
DE BRITO FERRARI Antonio	C	LEHTSAAR, Tõnu	A 2
DETREKOI, Akos	C	LISCHKA, Gunther	A 2
DIACONESCU, Stefan	C	LOBODA, Mirosław	C
DINU, Mihaela Sofia	D	LORBER, Lucka	A 2
DOSHI, Natasha	A 1	LU, Mu-Li N	B
DOUKA--KABITOGLOU, Ekaterini	A 1	LUTSIV, Ihor	A 1
DRAGAN, Simona Ruxanda	B	MADILL, Gerard	B
DRAGULESCU, Stefan Iosif	C	MAGAS, Damir	A 2
DRĂGULIN, Stela	D	MAKRIDES, Gerogory	A 1
DUMITRACHE, Ioan	C	MANTEL, Carsten	D
DURUIZ, Lale	B	MARC, Aurel	D
DUŞE, Dan	B	MARGA, Andrei	A 1
EGOROV, Vladimir	A 2	MĂRGHITAŞ, Liviu Alexandru	D
ESCOBAR DE LA SERNA, Luis	D	MARKKANEN, Tapio	A 2
FINCH, Andrew	B	MAROTO ÁLVAREZ, Concepción	D
FODOR, György	A 1	MARZA, Iacob	B
FRANJOU, Patrick	D	MCAHON, Frank	C
FREDERIKS, Mark	D	MELLET, Dominique	A 1
GAÁL, Zoltán	A 2	MENCER, Helena Jasna	A 1

MOLNÁR, István	A 1	VERWIJNEN, Jan	A 1
MOULOPOULOS, Konstantinos	C	VLASKOVIC, Bozin	A 1
MUNTEANU, Nicolae	A 2	WIJNEN, Albert	B
NAGY, Aladar	C	WINCKLER, Georg	D
NEWTON, Alice	B	WOJTYLA, Jan	D
NIEMI, Hannele	C	XISTO BRUNO, Raul Filipe	A 2
NIGLAS, Katrin	A 1	YASEV, Olexandr	A 2
NIKOLIC, Ruzica	A 2	YOUNG, David	D
NOVKOVIC, Nebojsa	C	ZANINETTI, Louise	A 1
OESTERGAARD, Joergen	A 2	ZEKI, Yilmaz	D
OLDE KALTER, Alex	D	ZIEJKA, Franciszek	D
OLIVIER, Philippe	A 2		
OPREAN, Constantin	D		
ÓZKALE, N. Lerzan	A 2		
PERKINS, John	A 1		
POCIUTE, Birute	C		
PONTAL, Claire	B		
POP, Ioan	D		
PRECUPANU, Teodor	B		
PROCHAZKA, Stanislav	D		
PUKÁNSZKY, Béla	D		
PUMPUTIS, Alvydas	A 2		
PUȘCĂ, Benone	C		
PUSKAS, Peter	B		
REISKA, Pritt	C		
RIBA, M. Dolors	A 2		
RIEGLER, Karin	D		
ROCKI, Marek	B		
ROUSSEL, Marie-Paule	A 1		
ROZMAN, Ivan	A 1		
RUIZ-RIVAS, Carmen	B		
SABAU, Marius	D		
SARI, Nebahat	D		
SAVOYE, Jose	C		
SBARCIU, Ioan	A 1		
SCHREUDERS, Wicher	B		
SCHULTE, Nina	A 1		
SECARES, Vasile	A 2		
SHABLIY, Oleh	A 1		
SIDLER, Fredy	D		
SMYNTYNA, Valentin	A 1		
SÓTÓNYI, Péter	C		
STAROVIC, Borisa	A 1		
STASIAK, Makary	B		
STAVE, Ola	D		
STEFANOVIC, Vladisav	C		
STRASZYNSKI, Ryszard	B		
SUPIN, Mikulas	A 1		
SURA, Pavel	D		
SUTTON, Susan	A 2		
SVEC, Juraj	C		
SYDNES, Leiv K.	B		
SZABÓ, Gábor	A 2		
SZILAGYI, Paul	D		
TAKALO, Tenho	A 2		
TALU, Nimet Hulya	B		
TAUCH, Christian	A 2		
TEMESI, Jozsef	A 1		
TEPLÁN, István	A 2		
THÓRHALLSSON, Tryggvi	A 2		
TODOROVIC, Ljiljana	C		
TOU-CHIU, Da-Rouin	A 1		
TUPPEN, John	B		
TYGIELSKI, Wojciech	D		
URGELL, Jaume	A 1		
VALANCIUTE, Angelija	C		
VAN DEN BERGH, Roger J.	A 2		
VAN DER DUYN SC., Frank A.	A 1		
VANDEUR, Marc	A 2		



The Rector's Office

ROMANIA

"BABEŞ-BOLYAI" CLUJ-NAPOCA

I, Mihail Kogălniceanu st., 400084 Cluj-Napoca

Tel. (00) 40 - 264 - 40.53.00*; 40.53.01; 40.53.02 ; 40.53.22

Fax: 40 - 264 - 59.19.06

E-mail: staff@staff.ubbcluj.ro

MOMENTUM

Andrei Marga

Rector of "Babeş-Bolyai" University

Welcome address

Opening of the 5th Conference of the

European University Association

Cluj, October, 24, 2003

Together with the academic staff, students and employees of our university I wish to address you a warm **BUN VENIT LA UNIVERSITATEA BABEŞ-BOLYAI, ISTEN HOZOTT, WILLKOMMEN, WELCOME, BIENVENUE, BENVENUTI, BIENVENIDOS, BEM-VINDO, DOBRO POZHALOVAT, BRUCHIM HABAIM, MIRE SE VINI, XOSH GĂLMISĂN, DOBRO DOSLI, DOBRE DOSHLI, VITEJTE, HUAN YING, VELKOMMEN, TERE TULEMAST, TERVETULOA, KALOS ORISATE, WELKOM, WELKOMEN, WITAJCIE, DOBRODOSHLI, DOBRODOSLI, VÄLKOMMEN, HOS GELDINIZ, LASKAVO PROSIMO!**

We are aware of the fact that many of our guests only know the city of Cluj and our university from readings. That is why I would like to mention that "Babeş-Bolyai" University has behind it the oldest academic history in Romania. The major landmarks in its historical development are: the Jesuit College of 1581; later the Reformed and Unitarian colleges; the Claudiopolitan Academy of 1688; Mary Theresa's project of establishing a university in German; the Lyceum established by Joseph II in 1785; the Hungarian university established by Franz Joseph in 1872; the Romanian university established by King Ferdinand I in 1919; the "Babeş" and "Bolyai" universities set up after World War II; the establishment of "Babeş-Bolyai" University in 1956; the decision taken in 1995 by the Senate to re-organise the university along three lines of study –

Romanian, Hungarian, and German, corresponding to the cultural-historical structure of Transylvania – and the legal recognition of this structure in 2000. After 1995, “Babeş-Bolyai” University assumed this entire academic history, along with all the advantages and requirements resulting from it.

It is stimulating that some cultural initiatives of international renown are related to the academic history of Cluj. Between 1571-72, not far from here, the first proclamation of religious tolerance in Europe was adopted. Cluj continues to be the historical and symbolical centre of the Unitarian Church. The beginnings of American philosophy and German poetry bear on the Transylvanian setting. It was in this university that, in 1877, the first comparative literature review in the world was issued. The beginnings of logic of interrogatives can be traced back here. Bio-speology was born here, significant pioneering contributions were made to space travel fundamental calculus, to the establishment of the history of science, to multiple telephony, and many others. Although situated in the provinces, the university of Cluj has permanently aspired to be in line with Western Europe and recognised as part of it.

After 1989, “Babeş-Bolyai” University set out to implement a comprehensive reform, whose measures focused on six areas: curricular reform, relaunching the scientific research, changing management, establishing new relations with the economic environment, modernising and introducing information technology in infrastructure, furthering new international co-operation forms. Real changes have taken place in the last decade in all these fields, and their effect is noticeable. However, as we know too well, many changes occurred in Romania, but major changes have yet to take place.

At present, “Babeş-Bolyai” University registers the largest development of the university in Cluj. With over 44,000 students, with its 20 faculties and 18 colleges, with its trilingual structure of studies, with acknowledged specialisations in hard sciences, humanities, economics and business, engineering, arts and physical education, with programmes for the learning of twenty-two languages, with four faculties of theology, “Babeş-Bolyai” University provides a wide range of study opportunities. Its academic management regards linguistic and cultural diversity as an asset and an advantage rather than a limit on otherness, and seeks to turn this diversity to good account. In consequence, never before have more Romanians studied in the main university of Transylvania. Never before have more Hungarians studied here. Never before have the opportunities for German studies been so large. Never before have the culture and history of the

Jewish people been studied so extensively. Never before have been mother tongues more cultivated in Transilvania than today in this university.

However, today the realistic prospects of a university do not relate to size, but to performance and competitiveness. In this respect, external evaluations rather than internal ones are decisive. That is why “Babeş-Bolyai” University has passed through three institutional evaluations of high expertise: that of the High Commissioner of OECD for Minorities (2000), that of the European University Association (2001), and that of the Salzburg Seminar (2002). Continuation of international evaluation is one of our concerns.

We know that the role of a university has not been completely played as long as inefficiency, corruption, lack of motivation and misinformation persist around. “Babeş-Bolyai” University has explicitly engaged in supporting democratisation and modernisation of the Romanian society. It decided to adopt the entrepreneurial formula and, in the last years, out of necessity, under the conditions of a precarious state allocation, it has come to provide 54% of the financial resources on its own, the rest being supplied from the state budget.

International co-operation has come as oxygen to this university. The provision adopted by the Senate of “Babeş-Bolyai” University in 1994, namely that each co-operation should have institutional results, has proved to be wise. Consequently, within the framework of European and American programmes, entire faculties, departments, subjects, laboratories have been organised, and mobilities have been generalised. However, it is high time to move towards deeper and more profitable forms of co-operation – joint curriculum and joint research units, along with all their implications in the association of universities, and we are very interested to take this step forward.

Einstein said, with good reason, that one cannot reach different goals by doing the same thing over and over again. Today our goals are new – improving research performance, competitiveness, and developing European solidarity. The **Declaration of Bologna**, the address of Salamanca, the communiqués of Prague and Berlin have envisaged these goals for universities. The creation of the “European higher education and research area” has become indispensable to Europeans. However, it has become clear today that such a programme can only be carried out by improving competitiveness of our own universities. We are aware that we need to do something else and in a different way. As a university seriously engaged in articulating the European higher education and research area, we wish to increase the weight of joint degrees

and, starting with the academic year 2003-2004, to introduce new mechanisms, such as “student of two universities” and “teaching staff with double appointment”, and to organise joint programmes in fields of excellence common to our university and partner universities in the region.

In Romania, we feel the need to continue the reforms and programmes related to curricula, quality assurance, expanding the application of ECTS and developing joint degrees, launched years ago. We have to admit that universities which have undergone effective reforms have a great potential in determining change for a knowledge-based society. We know that what a recent British document has lately well stated– “we will not compromise on quality” – can be reached by changing many things and by developing the European dimension of education, learning and research.

Trend 2003, the important analysis initiated by the European University Association, has clearly pointed the stage of academic study restructuring in Europe, and signalled open issues. This analysis has rightly observed, that “implementing the Bologna objectives becomes more fruitful if they are taken as package and related to each other”. The holistic perspective also proves indispensable when attempting at applying the **Declaration of Bologna**. This means, in effect, that “the links between creating a Bachelor/master degree structure, establishing an institution-wide credit transfer and less obvious to some, opening a lifelong learning perspective, have clearly emerged as points of synergy”.

We are delighted to host the 5th Conference of the European University Association and, together with you, distinguished colleagues, to look for juridical, financial and professional solutions to the key-problem of developing joint degrees within universities in Europe. I wish to thank all those who supported the idea of assigning “Babeş-Bolyai” University to the honour of organising this conference! Allow me to paraphrase what airline companies told you on your flight to Cluj: thank you for choosing our company these days! Allow me to thank our main sponsors: **DAAD (Bonn), UNESCO-CEPES (Bucharest), Banca Transilvania, Ursus, Banca Comercială Română, Carrefour, Terapia, Banc Post, Baunit, Reset Media, Allied Telesyn, ACI**, the other sponsors: **Profi Auto, Romtelecom, Flacăra, Leotex, Farmec, Microsoft, Someşul, Prodvinalco, Sistec, GPV Romania**, as well as our media partners: **Evenimentul Zilei, TVR Cluj, CD Radio**. Their support has been essential.

ADDRESS
by the President of Romania, Mr. ION ILIESCU,
to the Conference of the European Universities Association

- University Babeş-Bolyai, Cluj-Napoca, 23-26 October 2003-

(unofficial translation)

Distinguished guests,
Ladies and gentlemen,

I am extremely honoured to address you today, on the occasion of the present Conference of the European Universities Association, which, at its fifth edition, is hosted for the first time by Romania, namely by one of the most prestigious institutions of our higher education system – the Babeş-Bolyai University of Cluj-Napoca.

I believe the organizers rightfully see this event as a historic one – given the high-level participation, the representation of outstanding institutions, as well as the agenda of the debates which includes practical and substantial matters alike with a great relevance to the university and academic communities on our continent.

Entrusting the organization of this continental Conference of universities honours this university, the university system and our country alike. Therefore, I would like to take this opportunity to express my deep, permanent and sincere appreciation of the academic staff, the students and the board of the University from Cluj – not only for the achievement of hosting such an outstanding event, but also for the role model status of true European nature that the University Babeş-Bolyai has acquired in time and that it can set as an extremely inspiring example right now and in all respects.

Distinguished guests,

The very rich range of topics of this special event – **“UNIVERSITIES WORKING TOGETHER IN EUROPE: Integrated Programmes and Joint Degrees – a hallmark of the European Higher Education Area”** – urges me to share some of my personal considerations on the relations between the European and the national aspects, as well as between school and society. I am encouraged to do so mostly because this Conference of the European Universities Association takes place at a time when Europe has irreversibly engaged on the path of building a complex and multifunctional integration system. However, beyond the more or less high level of economic and legal integration, and without denying this continental remodelling, I believe that Europe still is an area of diversity and complementarities. The authentic European spirit rejects the excess of uniformity, levelling, and standardization by expressing itself as a living, dynamic spirit, animated by the regenerating virtues of multiculturalism.

We are thus persuaded that the evolution of the European spirit today consists in adding to a relatively standardized behaviour – especially from the economic and institutional perspectives – the specificity of a certain state of mind, of a European mentality that should lay the foundations of what we could call a European identity. Such an unmistakable and strong presence of the reunited Europe is more than necessary in the current age of globalization.

The European identity I refer to and which is about to be redefined involves both the set up of a flexible system of solidarity among the members of the vast European Family, as well as solid partnerships between the main centres of the current civilization, especially from the Euro-Atlantic area of the democratic world. Against this background, we should commend not only the effort to institutionalize such partnerships – such as the institution of the European Universities Association itself, but also the frequency and the substantiality of your dialogue in such continental conferences.

Where European solidarities are concerned, they involve an integrating cultural approach of the features of the old continent, the harmonization of regional, national and local peculiarities, the elimination of historic idiosyncrasies, of the geo-political “sizes” so much stressed upon in the media at the end of the past century. The current solidarities – economic or legal – shall be fully consolidated only through new cultural solidarities, within which the West shall be harmonized with the East, and the North with the Centre and the South; such an initiative can only be accomplished by means of rationality, humanism and pragmatism; these are features belonging traditionally to the highest academic spirit – that you stand for right here and right now – and that can lead to their re-assertion as essential sources of the pan-European solidarity.

Dear guests,

For Romanians, Europe has always meant home. Romanians grew in Europe and together with it, turning our continent into hope for freedom and modernization, into a guarantor of the state unity, a support of cultural assertion. This is why such an overwhelming number of our compatriots support Romania's accession to the European Union and the inclusion of our country in the Euro-Atlantic structures for security.

Together with the other peoples who came back to life in freedom over the past few decades, we hope in a Europe of Nations, a Europe of Solidarities, a Europe of Multicultural Civilization. A kind of Europe that "integrates itself" and is in line with the main trends of globalization with a distinct voice and participation, as an individual entity, in a relation of "partner emulation" with the major civilization centres at the beginning of this new century and new millennium. But the major centres of civilization, growing and spreading the contemporary European values, can only be the major university centres – just as the ones you represent today at this Conference.

Ladies and gentlemen,

The Fifth European Conference of universities is of special importance to Romania, as we believe that the perspectives for the modernization of the Romanian society are strictly dependent on the perspectives of higher education in our country, on its methodological and conceptual convergence with the European university systems. All structural development projects and all programs for the implementation of scientific developments in the Romanian economy can only be achieved with the human and professional support from specialists trained in the spirit of competition and high-performance, from higher education graduates that should be animated by the spirit of knowledge, as well as preoccupied by the real environment.

Over the past few years, reform was very much debated upon in our country, but I believe there is one important aspect of it that was a little left aside – I refer to the cultural aspect of reforms based on which new approaches, new mentalities, new means of communication and new global visions are developed. This is essentially a reform of attitude generated by a thorough specialized training, by the development of the wish for performance and efficiency, by the development of certain management skills which are vital in a market economy and which should be highly adaptable to the requirements and standards of the former. Thus, there is no effort too high when we must design the perspectives of our higher education, as well as the essential guidelines for academic scientific research.

The general objectives of the Romanian society, the performance criteria we must fulfil in order to be compatible and competitive in relation with the European civilization, are not only well known to us, but also fully assumed by all decision-makers in our country. However, what we need more clearly is to learn how to relate these objectives with our own tools and resources – especially human and intellectual – that we should use to accomplish them. Undoubtedly, among these tools and resources, a decisive role is played by the level of knowledge, the contribution of the academic and university elites, laying the training and education foundations required for professional performance and social relevance that the Romanian school as a whole must provide for the young generations of students.

For all these reasons, I would like to underline again the importance of this Conference for Romania, deeply hoping that your debates shall lead to many encouraging conclusions for the progress the Romanian higher education should make in this respect.

Ladies and gentlemen, I would like to express my highest consideration to all participants as well as to wish you welcome to the Fifth European Conference of Universities!

Ion Iliescu
President of Romania

Professor Dr. Theodor Berchem
President of the German Academic Exchange Service

5th EUA Conference

Joint Degrees

Short version

Romania, University of Cluj
Friday, 24th of October 2003; 9.00 a.m.

[Romania as a Host Country]

On the European map, we can easily identify the Carpathian Mountains as an Eastern extension of the Alps, with both linking, like a red line, the Eastern with the Western part of Europe. We all followed this line to meet in Romania, a country that will hopefully soon be part of the European community.

Europe, however, is much more than a geographical reality: It is an idea – an idea of unity, emerging from a common history and a joint cultural heritage. The country of Romania has considerably contributed to this rich cultural background, and I deeply appreciate the decision of the EUA board to hold this conference here in Cluj – all the more since the University of Cluj and my home university, the University of Würzburg, have a fruitful partnership of long standing.

It is a great pleasure to be here!

[Romania → Europe]

On the way from a centralized economy to a market economy after the dramatic events of 1989, Romania immediately increased interaction with other European countries. This was extremely important in the area of higher education and led to a rebuilding process that concentrated from the beginnings on creating study and research structures that were compatible with those in Europe. Since 1998, Romania joined the European mobility programmes, with positive consequences: Last year, to give an example, nearly 2.000 Romanian students went to other European countries on the base of Socrates/Erasmus scholarships, with France and Germany being the most popular host countries.

This impressive mobility may have some of its roots in traditional wisdom: *Cine porneste devreme, departe ajunge.*

[He who starts early arrives early], goes a Romanian proverb.

Ladies and gentleman, in this talk, I would like to demonstrate that this proverb is true in a double sense when it comes to the topic of joint degrees, both institutionally and individually:

[Joint Degrees]

Joint degree programmes help students to arrive in their future careers well-prepared for international challenges. Secondly, they help institutions of higher education to arrive timely at the destination given by the Bologna process.

I am convinced that, above all, joint degree programmes have one essential advantage: They contribute substantially to materialize the abstract idea of a common European higher education area. In less formal words: They add meat to the Bolognese sauce.

[three main contributions to the Bologna process]

I will demonstrate this nourishing effect in three different areas: First, joint degrees contribute to **mobility and employability**, second, they improve **transparency and cooperation** between universities, and third, they raise important **questions with regard to quality**.

Let us go right into these points, starting with **mobility and employability**. Joint degrees are especially attractive for students who want to build their career in a bi- or even multinational context: A joint degree diploma shows that the respective student achieved part of the qualification abroad. With mobility in Europe increasing, and with European degrees becoming more and more compatible, a joint degree diploma has an additional value:

It testifies – with one joint degrees or two degrees – that the student is familiar with at least two educational systems and their demands, which suggests that he or she will be able to better adapt to two or more national labour markets. A study initiated by the German University of Applied Sciences in Kiel revealed that German students with a joint degree earn around 30 percent more in average than their fellow graduates. [SZ vom 17.5.02]

With these advantages in mind, I was really surprised to learn that many joint degree programmes have recruiting problems. I give some examples from DAAD-sponsored programmes which we started in 1999:

Recruiting problems in these programmes – with a volume comprising more than 270 thousand euros per year – **first** have to do with destinations: Within our German-Polish programme, there are more Polish students who want to study in Germany than Germans heading for Poland. Within the German-British programme, the situation is reverse: Fewer British students and more German students are interested.

Second, the decision to study within a joint degree programme is a decision for a demanding curriculum that measurably exceeds expectations on a national level. With this background in mind, it is understandable that students hesitate to meet this challenge.

I think we have to accept these asymmetries and should just keep in mind that a certain and permanent amount of participating students is a minimal requirement for a joint-degree programme: The considerable investment in time, labour and funding should be justified. To attract more students, it seems reasonable to increase marketing initiatives specifically promoting joint degree programmes: I feel that in the area of marketing, we have a real backlog demand within Europe when it comes to joint degrees.

This takes me to my **second point**: Joint degrees help institutions of higher education to **communicate** and **cooperate** better, thus **achieving more transparency** in study structures as well as in study requirements.

Due to an increasing climate of competition – nationally and internationally – universities often seem to be rather rivals than partners. This market-oriented attitude has its reasons, but may unfortunately lead to considerable losses in the field of cooperation. Joint degree programmes, as a very determined form of cooperation, instead put an emphasis on lowering the thresholds while making the most from the specific strengths of all institutions involved.

This sounds great, but needs a considerable investment regarding time, energy and money:

➤ Creating a joint degree programme is a highly complex task.

Two or more universities have to define contents and standards of the new programme, have to create reasonable curricular structures and to split responsibilities for study modules. In this process, every participant gets a clearer view on their own institution, on its priorities, traditions and preferences. What, for instance, is special about their engineering programme? Where are national specifics that provide a real surplus value in a bi- or multinational context? A good start for this category of questions are French-German joint degree programmes:

The French-German University currently supports nearly 120 of these programmes with more than 3.000 students, and, due to the intense relations between our countries, we have the impression that joint degrees fill national shortcomings in higher education. As an example, German students in France highly estimate the clear orientation and guidance during their studies as well as the formal skills they acquire as a mandatory standard:

It is something they can rely on. French students are in return delighted about the freedom of choice they have during their time in German academic institutions. This setting has to be combined with questions of content:

What does a future engineer **have** to know in a French and German context?

What formal requirements have to be respected?

Where should the respective study modules be located?

- These questions, raised on an institutional level, quickly extend to more general issues that have to be dealt with:

What is a European master? What is a European engineer?

Which qualifications does a European lawyer need? Does the ECTS system efficiently document the qualifications acquired in different countries?

- Other general questions refer to obstacles: Efforts to create joint degrees often raise legal issues. Christian Tauch and Andrejs Rauhvargers, authors of the 2002 EUA survey on Master degrees and joint degrees in Europe, clearly revealed the various problems that may arise from different legal frameworks:

A student thus might not be allowed to enrol at two universities at the same time, or a national institution may demand such a long period of presence that the study period abroad has to be restricted.

In this context, it is also open what a "substantial period of time abroad" – as stated in the Berlin Communiqué as a condition for joint degrees – actually means. Other legal problems refer to the text appearing on degree certificates or degree names.

From a more general point of view, these obstacles are of course annoying, but, on the other hand, finally visible. Instruments such as joint degree programmes are wonderfully revealing: The bi- and multilateral dialogues detect legal, formal and structural obstacles that – in the shade of national borders – prevent the desired harmonisation in the European higher education area.

The **third point** I would like to address is the aspect of **quality**.

Joint degrees should be supported by a joint quality assurance. As you all know, this topic is intensely discussed with regard to the Bologna objectives. Last year's Stockholm conclusions on joint degrees clearly postulate:

"Principles and general standards for quality assurance and accreditation should be developed" – to guarantee international acceptance and competitiveness of the degree programmes. The Berlin Communique from last month includes an obligation for all member states to develop, until 2005, national quality assurance systems.

This means that every institution involved in joint degree programmes has to seek approval in the respective home country. Such a decentralized strategy has sound reasons and ensures autonomy.

However, this strategy has to be accompanied by a serious discussion on supranational standards and requirements. As an example, national accrediting agencies should be encouraged to engage in transnational networks:

Just as the joint degree programmes themselves, such networks encourage communication about common standards – in this case: about quality standards.

One of the main advantages for students in joint degree programmes is the fact that multilateral programmes maximise, in a best-case scenario, academic achievement insofar as the different strengths of the partners are efficiently combined. This is the real value joint degrees add to European higher education, and we should make sure across borders that every joint degree offers not a **cumulative**, but a **different** qualification.

Last but not least, we should develop reliable processes that identify bogus programmes containing some international make-up for additional profit.

Ladies and gentlemen, in the near future, we can expect Erasmus Mundus to add some dynamic to joint degrees within Europe and beyond. Joint programmes make sure that students from third countries get to know both the variety of European education and at least two European languages.

It will, however, be a real challenge for many students from other continents to acquire sufficient skills to follow their studies in two European languages. We should keep this in mind when discussing the pros and cons of Erasmus Mundus.

Whatever the formal challenges may be, joint degrees contribute to materialize the abstract idea of a common European higher education area. It should be **our** contribution to help promote this special instrument – individually, for the sake of students, and, even more so, institutionally: for the sake of considerable synergy effects on a European level.